

GS-2012 (Physics)  
**TATA INSTITUTE OF FUNDAMENTAL RESEARCH**

Written Test in **PHYSICS - December 11, 2011**

Duration : Three hours (3 hours)

Name : \_\_\_\_\_ Ref. Code : \_\_\_\_\_

**Please read all instructions carefully before you attempt the questions.**

1. Please fill-in details about name, reference code etc. on the question paper and answer sheet. The Answer Sheet is machine-readable. Read the instructions given on the reverse of the answer sheet before you start filling it up. Use only HB pencils to fill in the answer sheet.
2. Indicate your ANSWER ON THE ANSWER SHEET by blackening the appropriate circle for each question. Do not mark more than one circle for any question : this will be treated as a wrong answer.
3. This test comes in two sections, **Section A** and **Section B**, both of which contain multiple choice-type questions. Only ONE of the options given at the end of each question is correct. Section A contains 20 questions, each with 4 options, and Section B contains 10 questions, each with 5 options. The maximum marks are 60 for Section A plus 40 for Section B, totaling to 100. Marking shall be as follows :
  - (i) If the answer is **correct** : +3 marks in Section A; +4 marks in Section B
  - (ii) If the answer is **incorrect** : -1 mark in both Section A & B
  - (iii) If the answer is **not attempted** : 0 marks in both Section A & B
  - (iv) If **more than one box is marked** : 0 marks in both Section A & B

*Note that negative marking as indicated above will be implemented.*
4. As a rough guideline, the time spent on questions in Section A should be about 5 minutes each; questions in Section B should take about 8 minutes each. Obviously, some questions may take a little less time while others may require a little more.
5. We advise you to first mark the correct answers on the QUESTION PAPER and then to TRANSFER these to the ANSWER SHEET only when you are sure of your choice.
6. Rough work may be done on blank pages of the question paper. If needed, you may ask for extra rough sheets from an Invigilator.
7. Use of calculators is permitted. Calculator which plots graphs is NOT allowed. Multiple-use devices such as cell phones, smartphones etc., CANNOT be used for this purpose.
8. Do NOT ask for clarifications from the invigilators regarding the questions. They have been instructed not to respond to any such inquiries from candidates. In case a correction/clarification is deemed necessary, the invigilator(s) will announce it publicly.
9. List of useful **physical constants** is given on the next sheet.

## USEFUL CONSTANTS AND UNIT CONVERSIONS

| Symbol                               | Definition/Name                         | Value   |
|--------------------------------------|---|---|
| $c$                                  | Speed of light in vacuum                | $3.0 \times 10^8 \text{ m s}^{-1}$  |
| $\hbar$                              | reduced Planck constant ( $h/2\pi$ )    | $1.05 \times 10^{-34} \text{ J s}$  |
| $G_N$                                | Gravitational constant                  | $6.67 \times 10^{-11} \text{ m}^3 \text{ Kg}^{-1} \text{ s}^{-2}$   |
| $e$                                  | Electron charge (magnitude)             | $1.60 \times 10^{-19} \text{ C}$  |
| $\epsilon_0$                         | Permittivity of free space              | $8.85 \times 10^{-12} \text{ F m}^{-1}$   |
| $\mu_0$                              | permeability of free space              | $4\pi \times 10^{-7} \text{ N A}^{-2}$  |
| $k_B$                                | Boltzmann constant                      | $8.62 \times 10^{-5} \text{ eV K}^{-1} = 1.38 \times 10^{-23} \text{ J K}^{-1}$<br>$= 0.7 \text{ cm}^{-1} \text{ K}^{-1}$ |
| $m_e$                                | Electron mass                           | $0.5 \text{ MeV}/c^2 = 9.1 \times 10^{-31} \text{ Kg}$  |
| $m_n$                                | Neutron mass                            | $939.6 \text{ MeV}$   |
| $m_p$                                | Proton mass                             | $938.2 \text{ MeV}$   |
| $N_A$                                | Avogadro number                         | $6.023 \times 10^{23} \text{ mol}^{-1}$   |
| $R = k_B N_A$                        | Gas constant                            | $8.31 \text{ J mol}^{-1} \text{ K}^{-1}$  |
| $\gamma = C_P/C_V$                   | ratio of specific heats : monatomic gas | 1.67  |
|                                      | : diatomic gas                          | 1.40  |
| $g$                                  | Acceleration due to gravity (sea level) | $9.8 \text{ m s}^{-2}$  |
| $R_e$                                | Radius of the Earth                     | $6400 \text{ Km}$   |
| $R_s$                                | Radius of the Sun                       | $700000 \text{ Km}$   |
| $\sigma$                             | Stefan-Boltzmann constant               | $5.67 \times 10^{-8} \text{ W m}^{-2} \text{ K}^{-4}$   |
| $\hbar c$                            | Conversion constant                     | $197 \text{ MeV fm} = 3.16 \times 10^{-26} \text{ J m}$   |
| $\alpha = e^2/4\pi\epsilon_0\hbar c$ | Fine structure constant                 | 1/137   |
| $a_0 = 4\pi\epsilon_0\hbar^2/e^2m_e$ | Bohr radius                             | $0.51 \text{ \AA}$  |
|                                      | Ionisation energy of H atom             | $13.6 \text{ eV}$   |
| $r_0$                                | nuclear radius $r = r_0 A^{1/3}$        | $1.2 \text{ fm}$  |

|                |                      |   |
|----------------|----------------------|---|
| 1 $\text{\AA}$ | Ångstrom unit        | $10^{-10} \text{ m}$  |
| 1 eV           | electron Volt        | $1.60 \times 10^{-19} \text{ J}$                                  |
| 1 T            | Tesla                | $10^4 \text{ Gauss}$  |
| 1 W            | Watt                 | $1 \text{ J s}^{-1}$  |
| 1 bar          | atmospheric pressure | $1.01 \times 10^5 \text{ Pa} = 1.01 \times 10^5 \text{ N m}^{-2}$ |
| 1 a.m.u.       | atomic mass unit     | $1.66 \times 10^{-27} \text{ Kg}$                                 |

---

**GS-2012-X (PHYSICS)**

---

**A Section**

Marks:  $20 \times 3 = 60$

Time: 100 minutes (approx.)

---

A1. Two different  $2 \times 2$  matrices  $A$  and  $B$  are found to have the same eigenvalues. It is then correct to state that  $A = SBS^{-1}$  where  $S$  can be a

- (a) traceless  $2 \times 2$  matrix                      (b) Hermitian  $2 \times 2$  matrix  
(c) unitary  $2 \times 2$  matrix ✓                      (d) arbitrary  $2 \times 2$  matrix

A2. The function  $f(x)$  represents the nearest integer less than  $x$ , e.g.

$$f(3.14) = 3.$$

The derivative of this function (for arbitrary  $x$ ) will be given in terms of the integers  $n$  as  $f'(x) =$

- (a) 0                      (b)  $\sum_n \delta(x - n)$  ✓                      (c)  $\sum_n |x - n|$                       (d)  $\sum_n f(x - n)$

A3. Two masses  $M_1$  and  $M_2$  ( $M_1 < M_2$ ) are suspended from a perfectly rigid horizontal support by a system of three taut massless wires  $W_1$ ,  $W_2$  and  $W_3$ , as shown in the figure. All the three wires have identical cross-sections and elastic properties and are known to be very strong.

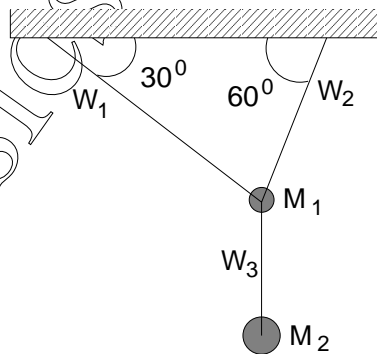

If the mass  $M_2$  is increased gradually, but without limit, we should expect the wires to break in the following order:

- (a) first  $W_2$ , then  $W_1$                       (b) first  $W_1$ , then  $W_2$   
(c) first  $W_2$ , then  $W_3$                       (d) first  $W_3$  ✓

A4. A high-velocity missile, travelling in a horizontal line with a kinetic energy of 3.0 Giga-Joules (GJ), explodes in flight and breaks into two pieces A and B of equal mass. One of these pieces (A) flies off in a straight line perpendicular to the original direction in which the missile was moving and its kinetic energy is found to be 2.0 GJ. If gravity can be neglected for such high-velocity projectiles, it follows that the other piece (B) flew off in a direction at an angle with the original direction of

- (a)  $30^\circ$  ✓ (b)  $33^\circ 24'$  (c)  $45^\circ$  (d)  $60^\circ$

A5. Consider a spherical planet, rotating about an axis passing through its centre. The velocity of a point on its equator is  $v_{eq}$ . If the acceleration due to gravity  $g$  measured at the equator is half of the value of  $g$  measured at one of the poles, then the escape velocity for a particle shot upwards from that pole will be

- (a)  $v_{eq}/2$  (b)  $v_{eq}/\sqrt{2}$  (c)  $\sqrt{2}v_{eq}$  (d)  $2v_{eq}$  ✓

A6. A dynamical system with two degrees of freedom, has generalised coordinates  $q_1$  and  $q_2$ , and kinetic energy

$$T = \lambda \dot{q}_1 \dot{q}_2$$

If the potential energy is  $V(q_1, q_2) = 0$ , the correct form of the Hamiltonian for this system is

- (a)  $p_1 p_2 / \lambda$  ✓ (b)  $\lambda \dot{q}_1 \dot{q}_2$   
 (c)  $(p_1 \dot{q}_1 + p_2 \dot{q}_2) / 2$  (d)  $(p_1 q_2 + p_2 q_1) / 2$

A7. An ideal liquid of density 1 gm/cc is flowing at a rate of 10 gm/s through a tube with varying cross-section, as shown in the figure.

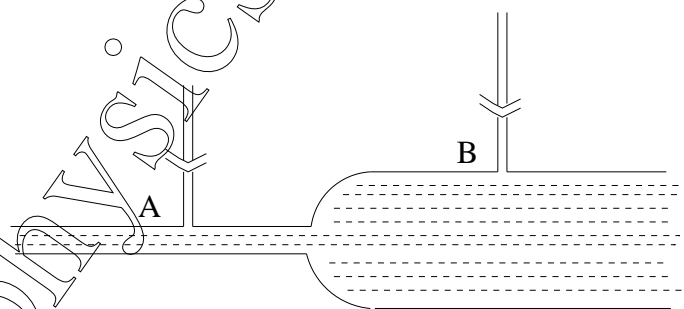

Two pressure gauges attached at the points A and B (see figure) show readings of  $P_A$  and  $P_B$  respectively. If the radius of the tube at the points A and B is 0.2 cm and 1.0 cm respectively, then the difference in pressure ( $P_B - P_A$ ), in units of  $\text{dyne cm}^{-2}$ , is closest to

- (a) 100 (b) 120 ✓ (c) 140 (d) 160

- A8. Unpolarised light of intensity  $I_0$  passes successively through two identical linear polarisers A and B, placed such that their polarisation axes are at an angle of  $45^\circ$  (see figure) with respect to one another.

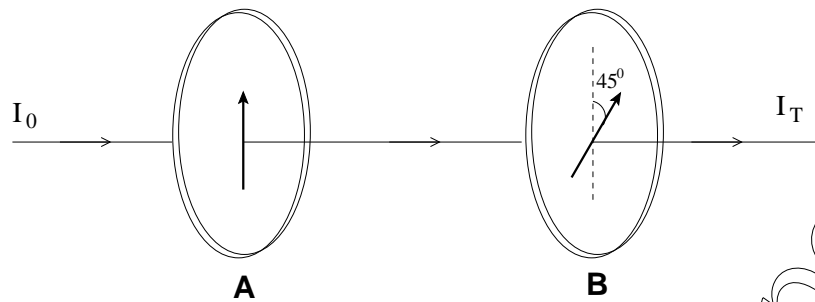

Assuming A and B to be perfect polarisers (i.e. no absorption losses), the intensity of the transmitted light will be  $I_T =$

- (a)  $I_0/4$  ✓ (b)  $I_0/2\sqrt{2}$  (c)  $I_0/2$  (d)  $I_0/\sqrt{2}$

- A9. Three equal charges  $Q$  are successively brought from infinity and each is placed at one of the three vertices of an equilateral triangle. Assuming the rest of the Universe as a whole to be neutral, the energy  $E_0$  of the electrostatic field will increase, successively, to

$$E_0 + \Delta_1, \quad E_0 + \Delta_1 + \Delta_2, \quad E_0 + \Delta_1 + \Delta_2 + \Delta_3$$

where  $\Delta_1 : \Delta_2 : \Delta_3 =$

- (a) 1 : 2 : 3 (b) 1 : 1 : 1 (c) 0 : 1 : 1 (d) 0 : 1 : 2 ✓

- A10. Five sides of a hollow metallic cube are grounded and the sixth side is insulated from the rest and is held at a potential  $\Phi$  (see figure).

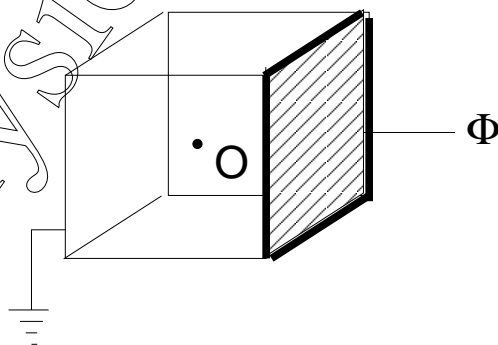

The potential at the center O of the cube is

- (a) 0 (b)  $\Phi/6$  ✓ (c)  $\Phi/5$  (d)  $2\Phi/3$

- A11. Consider a sealed but thermally conducting container of total volume  $V$ , which is in equilibrium with a thermal bath at temperature  $T$ . The container is divided into two equal chambers by a thin but impermeable partition. One of these chambers contains an ideal gas, while the other half is a vacuum (see figure).

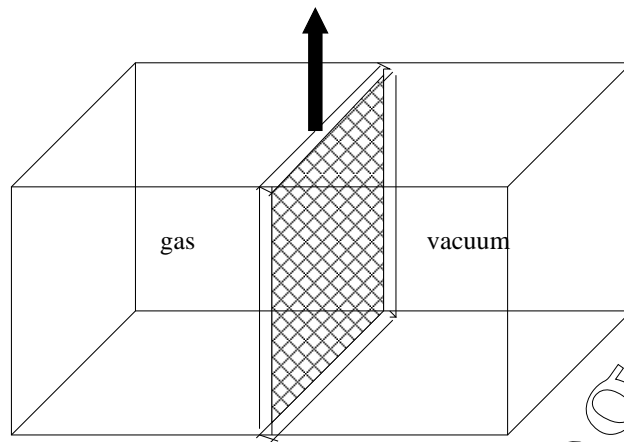

If the partition is removed and the ideal gas is allowed to expand and fill the entire container, then the entropy per molecule of the system will increase by an amount

- (a)  $2k_B$       (b)  $k_B \ln(1/2)$       (c)  $k_B \ln 2$  ✓      (d)  $(k_B \ln 2)/2$

- A12. When a gas is enclosed in an impermeable box and heated to a high temperature  $T$ , some of the neutral atoms lose an electron and become ions. If the number density of neutral atoms, ions and electrons is  $N_a$ ,  $N_i$  and  $N_e$ , respectively, these can be related to the average volume  $V_a$  occupied by an atom/ion and the ionisation energy  $E$  by the relation

- (a)  $N_e(N_a + N_i) = (N_a/V_a) \exp(-E/k_B T)$   
 (b)  $N_a(N_e + N_i) = (N_a/V_a) \exp(-E/k_B T)$   
 (c)  $N_e N_i = (N_a/V_a) \exp(+E/k_B T)$   
 (d)  $N_e N_i = (N_a/V_a) \exp(-E/k_B T)$  ✓

- A13. In a scanning tunnelling microscope, a fine Platinum needle is held close to a metallic surface in vacuum and electrons are allowed to tunnel across the tiny gap  $\delta$  between the surface and the needle. The tunnelling current  $I$  is related to the gap  $\delta$ , through positive constants  $a$  and  $b$ , as

- (a)  $I = a - b\delta$       (b)  $I = a + b\delta$   
 (c)  $\log I = a - b\delta$  ✓      (d)  $\log I = a + b\delta$

A14. A particle in a one-dimensional potential has the wavefunction

$$\psi(x) = \frac{1}{\sqrt{a}} \exp\left(\frac{-|x|}{a}\right)$$

where  $a$  is a constant. It follows that for a positive constant  $V_0$ , the potential  $V(x)$

- (a)  $V_0 x^2$       (b)  $V_0 |x|$       (c)  $-V_0 \delta(x)$  ✓      (d)  $-V_0/|x|$

A15. Consider the high excited states of a Hydrogen atom corresponding to large values of the principal quantum number ( $n \gg 1$ ). The wavelength  $\lambda$  of a photon emitted due to an electron undergoing a transition between two such states with consecutive values of  $n$  (i.e.  $\psi_{n+1} \rightarrow \psi_n$ ) is related to the wavelength  $\lambda_\alpha$  of the  $K_\alpha$  line of Hydrogen by

- (a)  $\lambda = n^3 \lambda_\alpha / 8$       (b)  $\lambda = 3n^3 \lambda_\alpha / 8$  ✓  
 (c)  $\lambda = n^2 \lambda_\alpha$       (d)  $\lambda = 4\lambda_\alpha / n^2$

A16. A proton is accelerated to a high energy  $E$  and shot at a nucleus of Oxygen ( $^{16}_8\text{O}$ ). In order to penetrate the Coulomb barrier and reach the surface of the Oxygen nucleus,  $E$  must be at least

- (a) 3.6 MeV ✓      (b) 1.8 MeV      (c) 45 keV      (d) 180 eV

A17. A monochromatic beam of X-rays with wavelength  $\lambda$  is incident at an angle  $\theta$  on a crystal with lattice spacings  $a$  and  $b$  as sketched in the figure below.

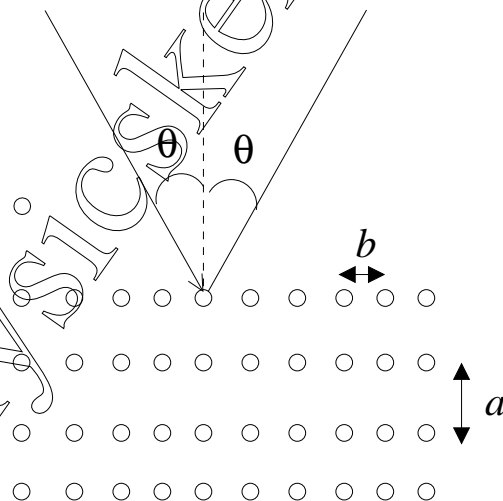

A condition for there to be a maximum in the diffracted X-ray intensity is

- (a)  $2\sqrt{a^2 + b^2} \sin \theta = \lambda$       (b)  $2b \cos \theta = \lambda$   
 (c)  $2a \cos \theta = \lambda$  ✓      (d)  $(a + b) \sin \theta = \lambda$

A18. Suppose the energy band diagram of a certain pure crystalline solid is as shown in the figure below, where the energy ( $E$ ) varies with crystal momentum ( $k$ ) as  $E \propto k^2$ .

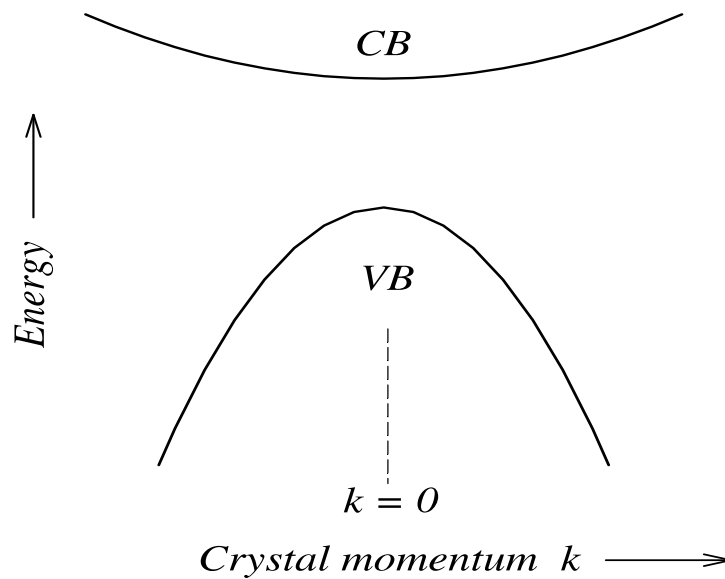

At finite temperatures the bottom of the conduction band (CB) is partially filled with electrons ( $e$ ) and the top of the valence band (VB) is partially filled with holes ( $h$ ). If an electric field is applied to this solid, both  $e$  and  $h$  will start moving. If the time between collisions is the same for both  $e$  and  $h$ , then

- (a)  $e$  and  $h$  will move with the same speed in opposite directions
- (b)  $h$  will on an average achieve higher speed than  $e$  ✓
- (c)  $e$  will on an average achieve higher speed than  $h$
- (d)  $e$  and  $h$  will recombine and after a while there will be no flow of charges

A19. Consider the circuit shown below.

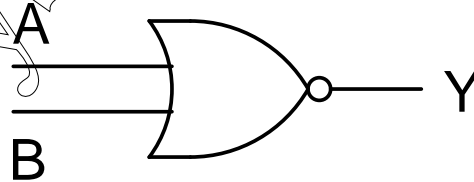

The minimum number of NAND gates required to design this circuit is

- (a) 6
- (b) 5
- (c) 4 ✓
- (d) 3



A20. Consider the following circuit:

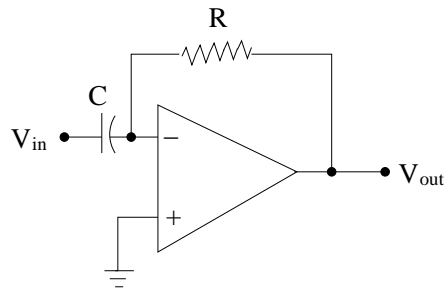

If the waveform given below is fed in at  $V_{in}$ ,

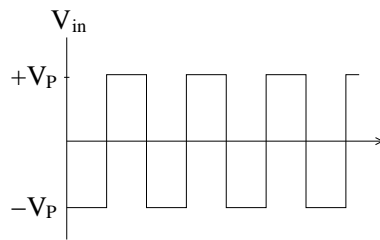

then the waveform at the output  $V_{out}$  will be

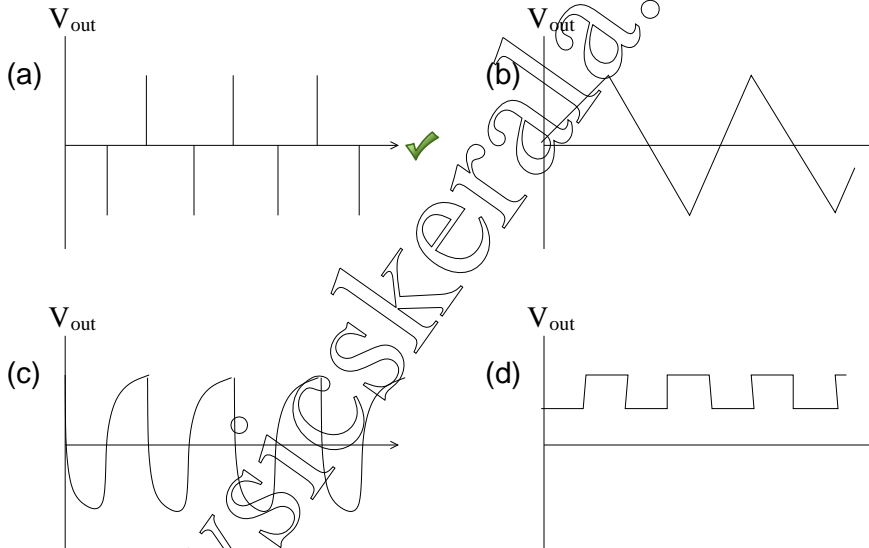

---

**GS-2012-X (PHYSICS)**

---

**B Section**

Marks:  $10 \times 4 = 40$

Time: 80 minutes (approx.)

---

B1. Consider the integral

$$\int_{-p^2}^{+p^2} \frac{dx}{\sqrt{x^2 - p^2}}$$

where  $p$  is a constant. This integral has a real, nonsingular value if

- (a)  $p < -1$     (b)  $p > 1$     (c)  $p = 1$     (d)  $p \rightarrow 0$  ✓    (e)  $p \rightarrow \infty$

B2. If we model the electron as a uniform sphere of radius  $r_e$ , spinning uniformly about an axis passing through its centre with angular momentum  $L_e = \hbar/2$ , and demand that the velocity of rotation at the equator cannot exceed the velocity  $c$  of light in vacuum, then the minimum value of  $r_e$  is

- (a) 19.2 fm    (b) 0.192 fm    (c) 4.8 fm    (d) 1960 fm    (e) 480 fm ✓

B3. The intensity of light coming from a distant star is measured using two identical instruments A and B, where A is placed in a satellite outside the Earth's atmosphere, and B is placed on the Earth's surface. The results are as follows:

| colour | wavelength<br>(nm) | intensity at A<br>(nanoWatts) | intensity at B<br>(nanoWatts) |
|--------|--------------------|-------------------------------|-------------------------------|
| green  | 500                | 100                           | 50                            |
| red    | 700                | 200                           | $x$                           |

Assuming that there is scattering, but no absorption of light in the Earth's atmosphere at these wavelengths, the value of  $x$  can be estimated as

- (a) 137    (b) 147    (c) 157    (d) 167 ✓    (e) 177

B4. Consider three identical infinite straight wires A, B and C arranged in parallel on a plane as shown in the figure.

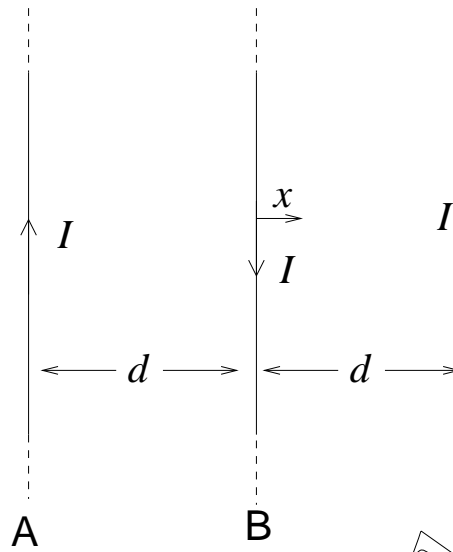

The wires carry equal currents  $I$  with directions as shown in the figure and have mass per unit length  $m$ . If the wires A and C are held fixed and the wire B is displaced by a small distance  $x$  from its position, then it (B) will execute simple harmonic motion with a time period

- (a)  $2\pi\sqrt{\frac{m}{\pi\mu_0}}\left(\frac{d}{I}\right)$       (b)  $2\pi\sqrt{\frac{2\pi m}{\mu_0}}\left(\frac{d}{I}\right)$       (c)  $2\pi\sqrt{\frac{\pi m}{\mu_0}}\left(\frac{d}{I}\right)$  ✓  
 (d)  $2\pi\sqrt{\frac{m}{2\pi\mu_0}}\left(\frac{d}{I}\right)$       (e)  $2\pi\sqrt{\frac{m}{\mu_0}}\left(\frac{d}{I}\right)$

B5. The normalized wavefunctions of a Hydrogen atom are denoted by  $\psi_{n,\ell,m}(\vec{x})$ , where  $n$ ,  $\ell$  and  $m$  are, respectively, the principal, azimuthal and magnetic quantum numbers respectively. Now consider an electron in the mixed state

$$\Psi(\vec{x}) = \frac{1}{3}\psi_{1,0,0}(\vec{x}) + \frac{2}{3}\psi_{2,1,0}(\vec{x}) + \frac{2}{3}\psi_{3,2,-2}(\vec{x})$$

The expectation value  $\langle E \rangle$  of the energy of this electron, in electron-Volts (eV) will be approximately

- (a) -1.5      (b) -3.7 ✓      (c) -13.6      (d) -80.1      (e) +13.6

B6. The strongest three lines in the emission spectrum of an interstellar gas cloud are found to have wavelengths  $\lambda_0$ ,  $2\lambda_0$  and  $6\lambda_0$  respectively, where  $\lambda_0$  is a known wavelength. From this we can deduce that the radiating particles in the cloud behave like

- (a) free particles      (b) particles in a box      (c) harmonic oscillators  
 (d) rigid rotators ✓      (e) hydrogenic atoms

B7. When light is emitted from a gas of excited atoms, the lines in the spectrum are Doppler-broadened due to the thermal motion of the emitting atoms.

The Doppler width of an emission line of wavelength 500 nanometres (nm) emitted by an excited atom of Argon ( $^{40}_{20}\text{A}$ ) at room temperature ( $27^\circ\text{C}$ ) can be estimated as

- (a)  $5.8 \times 10^{-4}$  nm      (b)  $3.2 \times 10^{-4}$  nm      (c)  $3.2 \times 10^{-3}$  nm  
 (d)  $2.5 \times 10^{-3}$  nm      (e)  $1.4 \times 10^{-3}$  nm ✓

B8. In a nuclear reactor, Plutonium ( $^{239}_{94}\text{Pu}$ ) is used as fuel, releasing energy by its fission into isotopes of Barium ( $^{146}_{54}\text{Ba}$ ) and Strontium ( $^{91}_{38}\text{Sr}$ ) through the reaction



The binding energy (B.E.) per nucleon of each of these nuclides is given in the table below:

| Nuclide                | $^{239}_{94}\text{Pu}$ | $^{146}_{54}\text{Ba}$ | $^{91}_{38}\text{Sr}$ |
|------------------------|------------------------|------------------------|-----------------------|
| B.E. per nucleon (MeV) | 7.6                    | 8.2                    | 8.6                   |

Using this information, one can estimate the number of such fission reactions per second in a 100 MW reactor as

- (a)  $3.9 \times 10^{18}$  ✓      (b)  $7.8 \times 10^{18}$       (c)  $5.2 \times 10^{19}$   
 (d)  $5.2 \times 10^{18}$       (e)  $8.9 \times 10^{17}$

B9. Metallic Copper is known to form cubic crystals and the lattice constant is measured from X-ray diffraction studies to be about 0.36 nm. If the specific gravity of Copper is 8.96 and its atomic weight is 63.5, one can conclude that

- (a) the crystals are of simple cubic type  
 (b) the crystals are of b.c.c. type  
 (c) the crystals are of f.c.c. type ✓  
 (d) the crystals are a mixture of f.c.c. and b.c.c. types  
 (e) there is insufficient data to distinguish between the previous options

B10. The voltage regulator circuit shown in the figure has been made with a Zener diode rated at 15 V, 200 mW. It is required that the circuit should dissipate 150 mW power across the fixed load resistor  $R_L$ .

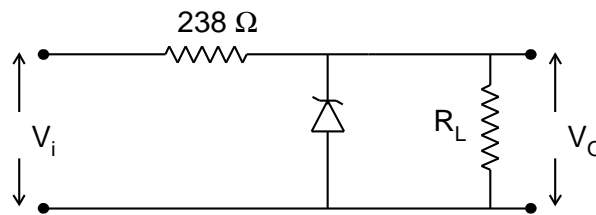

For stable operation of this circuit, the input voltage  $V_i$  must have a range

- (a) 17.5 V — 20.5 V ✓
- (b) 15.5 V — 20.5 V
- (c) 15.5 V — 22.5 V
- (d) 17.5 V — 22.5 V
- (e) 15.0 V — 22.5 V

---

**Rough Work**

**GS-2012 (PHYSICS)**

**PHY-X**

**ANSWER SHEET**

Please see reverse for instructions on filling of answer sheet.

Question Paper Set : X ● Y ○

|                 |  |                         |   |   |   |   |
|-----------------|--|-------------------------|---|---|---|---|
| <b>Name</b>     |  | <b>Reference Code :</b> |   |   |   |   |
| <b>Ref Code</b> |  | 1                       | ○ | ○ | ○ | ○ |
| <b>Address</b>  |  | 2                       | ○ | ○ | ○ | ○ |
|                 |  | 3                       | ○ | ○ | ○ | ○ |
|                 |  | 4                       | ○ | ○ | ○ | ○ |
|                 |  | 5                       | ○ | ○ | ○ | ○ |
| <b>Phone</b>    |  | 6                       | ○ | ○ | ○ | ○ |
| <b>Email</b>    |  | 7                       | ○ | ○ | ○ | ○ |
|                 |  | 8                       | ○ | ○ | ○ | ○ |
|                 |  | 9                       | ○ | ○ | ○ | ○ |
|                 |  | 0                       | ○ | ○ | ○ | ○ |

Would you like to be considered for Biology also :

YES ○

NO ○

| SECTION-A |     |     |     |     |
|-----------|-----|-----|-----|-----|
|           | (a) | (b) | (c) | (d) |
| 1         | ○   | ○   | ○   | ○   |
| 2         | ○   | ○   | ○   | ○   |
| 3         | ○   | ○   | ○   | ○   |
| 4         | ○   | ○   | ○   | ○   |
| 5         | ○   | ○   | ○   | ○   |
| 6         | ○   | ○   | ○   | ○   |
| 7         | ○   | ○   | ○   | ○   |
| 8         | ○   | ○   | ○   | ○   |
| 9         | ○   | ○   | ○   | ○   |
| 10        | ○   | ○   | ○   | ○   |
| 11        | ○   | ○   | ○   | ○   |
| 12        | ○   | ○   | ○   | ○   |
| 13        | ○   | ○   | ○   | ○   |
| 14        | ○   | ○   | ○   | ○   |
| 15        | ○   | ○   | ○   | ○   |
| 16        | ○   | ○   | ○   | ○   |
| 17        | ○   | ○   | ○   | ○   |
| 18        | ○   | ○   | ○   | ○   |
| 19        | ○   | ○   | ○   | ○   |
| 20        | ○   | ○   | ○   | ○   |

| SECTION-B |     |     |     |     |     |
|-----------|-----|-----|-----|-----|-----|
|           | (a) | (b) | (c) | (d) | (e) |
| 1         | ○   | ○   | ○   | ○   | ○   |
| 2         | ○   | ○   | ○   | ○   | ○   |
| 3         | ○   | ○   | ○   | ○   | ○   |
| 4         | ○   | ○   | ○   | ○   | ○   |
| 5         | ○   | ○   | ○   | ○   | ○   |
| 6         | ○   | ○   | ○   | ○   | ○   |
| 7         | ○   | ○   | ○   | ○   | ○   |
| 8         | ○   | ○   | ○   | ○   | ○   |
| 9         | ○   | ○   | ○   | ○   | ○   |
| 10        | ○   | ○   | ○   | ○   | ○   |

\_\_\_\_\_  
Signature of the Student

### INSTRUCTIONS

The Answer Sheet is machine-readable. Apart from filling in the details on the answer sheet, please make sure that the Reference Code is filled by blackening the appropriate circles in the box provided on the right-top corner. Only use HB pencils to fill-in the answer sheet.

e.g. if your reference code is 15207 :

| Reference Code : |                                  |                                  |                                  |                                  |                                  |
|------------------|----------------------------------|----------------------------------|----------------------------------|----------------------------------|----------------------------------|
| 1                | <input checked="" type="radio"/> | <input type="radio"/>            | <input type="radio"/>            | <input type="radio"/>            | <input type="radio"/>            |
| 2                | <input type="radio"/>            | <input type="radio"/>            | <input checked="" type="radio"/> | <input type="radio"/>            | <input type="radio"/>            |
| 3                | <input type="radio"/>            | <input type="radio"/>            | <input type="radio"/>            | <input type="radio"/>            | <input type="radio"/>            |
| 4                | <input type="radio"/>            | <input type="radio"/>            | <input type="radio"/>            | <input type="radio"/>            | <input type="radio"/>            |
| 5                | <input type="radio"/>            | <input checked="" type="radio"/> | <input type="radio"/>            | <input type="radio"/>            | <input type="radio"/>            |
| 6                | <input type="radio"/>            | <input type="radio"/>            | <input type="radio"/>            | <input type="radio"/>            | <input type="radio"/>            |
| 7                | <input type="radio"/>            | <input type="radio"/>            | <input type="radio"/>            | <input type="radio"/>            | <input checked="" type="radio"/> |
| 8                | <input type="radio"/>            | <input type="radio"/>            | <input type="radio"/>            | <input type="radio"/>            | <input type="radio"/>            |
| 9                | <input type="radio"/>            | <input type="radio"/>            | <input type="radio"/>            | <input type="radio"/>            | <input type="radio"/>            |
| 0                | <input type="radio"/>            | <input type="radio"/>            | <input type="radio"/>            | <input checked="" type="radio"/> | <input type="radio"/>            |

Also, the multiple choice questions are to be answered by blackening the appropriate circles as described below

e.g. if your answer to question 1 is (b)  
and your answer to question 2 is (d)  
then .....

| SECTION A |                       |                                  |                       |                                  |
|-----------|-----------------------|----------------------------------|-----------------------|----------------------------------|
|           | (A)                   | (B)                              | (C)                   | (D)                              |
| 1         | <input type="radio"/> | <input checked="" type="radio"/> | <input type="radio"/> | <input type="radio"/>            |
| 2         | <input type="radio"/> | <input type="radio"/>            | <input type="radio"/> | <input checked="" type="radio"/> |
| 3         | <input type="radio"/> | <input type="radio"/>            | <input type="radio"/> | <input type="radio"/>            |
| 4         | <input type="radio"/> | <input type="radio"/>            | <input type="radio"/> | <input type="radio"/>            |