

Lecture Notes on Discrete Mathematics

A. K. Lal

October 3, 2008

Contents

1	Counting and Permutations	5
1	Principles of Basic Counting	6
2	Indistinguishable Objects	12
	2.A Partitions	14
	2.B Miscellaneous Exercises	15
3	Round Table Configurations	16
4	Lattice Paths	17
5	Some Generalizations	22
2	Advanced Counting	27
1	Principle of Mathematical Induction	27
2	Pigeonhole Principle	30
3	Principle of Inclusion and Exclusion	35
3	Polya Theory	39
1	Groups	39
2	Subgroup	46
3	Lagrange's Theorem	48
	3.A Applications of Lagrange's Theorem	51
4	Symmetric Groups	52
5	Group Action	54
6	The Cycle Index Polynomial	59
	6.A Applications	59
	6.B Polya's Inventory Polynomial	61
4	Generating Functions and Its Applications	67
1	Formal Power Series	67
2	Recurrence Relation	73

3	Applications of Generating Functions	79
5	Answers and Hints	83
1	Counting and Permutations	83
2	Mathematical Induction	92
3	Pigeonhole Principle	93
4	Inclusion and Exclusion	97

Chapter 1

Counting and Permutations

The following notations will be used:

1. The sets \mathbb{N} , \mathbb{W} , \mathbb{Z} , \mathbb{Q} and \mathbb{R} , respectively, denote the set of natural numbers, whole numbers, integers, rational numbers and real numbers.
2. If A is a finite set then $|A|$ denotes the number of elements in the set A . ALL THE SETS IN THESE NOTES ARE SUPPOSED TO BE FINITE UNLESS STATED OTHERWISE.
3. For a positive integer n , the set $\{1, 2, \dots, n\}$ is denoted by A_n .

Axioms:

1. Let A and B be two non-empty finite disjoint subsets of a set S . Then

$$|A \cup B| = |A| + |B|.$$

2. If $A \times B = \{(a, b) : a \in A, b \in B\}$ then $|A \times B| = |A| \cdot |B|$.

That is, if one work can be done in $m = |A|$ ways and a second work can be done in $n = |B|$ ways (independent of how the first work is done) then the total work (consisting of the above two) can be done in mn ways.

3. If there exists a one-to-one and onto function $f : A \rightarrow B$ then $|A| = |B|$.

Exercise 1.0.1 1. *In a class there are 30 boys and 20 girls. Then what is the total number of students in the class?*

2. *A fast food chain at Rave uses three types of bread, two types of cheese and three types of toppings. Then what is the maximum number of menu items can it have?*

3. How many ways are there to make a 4 letter words with a consonant as the first letter and a vowel as the second letter?
4. How many 5-letter words using only A's, B's, C's, and D's are there that do not contain the word "CAD"?

1 Principles of Basic Counting

Example 1.1.1 If $|M| = m$ and $|N| = n$ then what is the total number of functions $f : M \rightarrow N$?

Solution: Let $M = \{a_1, a_2, \dots, a_m\}$ and $N = \{b_1, b_2, \dots, b_n\}$ and let $f : M \rightarrow N$ be any function. we know that a function is determined as soon as we know the value of $f(a_i)$ for $1 \leq i \leq m$. That is, a function $f : M \rightarrow N$ has the form

$$f \leftrightarrow \begin{pmatrix} a_1 & a_2 & \cdots & a_m \\ f(a_1) & f(a_2) & \cdots & f(a_m) \end{pmatrix},$$

where $f(a_i) \in \{b_1, b_2, \dots, b_n\}$ for $1 \leq i \leq m$. As there is no restriction on the function f , $f(a_1)$ can be any one of the b_j 's (n choices), $f(a_2)$ can be any one of the b_j 's and this choice is independent of what $f(a_1)$ is (n choices), and so on. Thus, the total number of functions $f : M \rightarrow N$ is

$$\underbrace{n \cdot n \cdot \cdots \cdot n}_{m \text{ times}} = n^m.$$

■

Remark 1.1.2 The question "If $|M| = m$ and $|N| = n$ then what is the total number of functions $f : M \rightarrow N$?" is same as the following question:

In how many ways can m **distinguishable** balls by put into n **distinguishable** boxes.

Exercise 1.1.3 1. How many ways are there to make a 3 letter word?

2. How many possible sequence of outcomes are there if k dice are tossed?

Example 1.1.4 If $|M| = m$ and $|N| = n$ then what is the total number of one-to-one functions $f : M \rightarrow N$?

Solution: Observe that the condition

$$\begin{aligned} f \text{ is one-to-one} &\Leftrightarrow \text{whenever } f(x) = f(y), \text{ we must have } x = y \\ &\Leftrightarrow \text{if } x \neq y \text{ then } f(x) \neq f(y). \end{aligned}$$

Therefore, if $m > n$, then the number such functions is 0.

So, let us assume that $m \leq n$. Thus, once $f(a_1)$ is chosen (n choices), there are only $n - 1$ independent choices for $f(a_2)$ ($f(a_2)$ has to be chosen from the set $\{b_1, b_2, \dots, b_n\} - \{f(a_1)\}$), there are only $n - 2$ independent choices for $f(a_3)$ ($f(a_3)$ has to be chosen from the set $\{b_1, b_2, \dots, b_n\} - \{f(a_1), f(a_2)\}$), and so on. Thus, the required number is

$$n \cdot (n - 1) \cdot (n - 2) \cdots (n - m + 1) = \frac{n!}{(n - m)!} \quad \text{denoted } n_{(m)},$$

called the falling factorial of n . We also call it by saying “number of m -permutations of n distinguishable objects”. ■

Exercise 1.1.5 1. How many possible ways are there to make 3 letter words if the letters must be different?

2. How many possible ways are there for 3 persons to sit in 5 chairs that are in a row?

3. How many possible ways are there to arrange the 5 letters of the word $ABCDE$?

4. How many possible ways are there to arrange the 5 letters of the word $A_1 A_2 A_3 E_4 E_5$?

5. How many possible ways can 8 persons, including Ram and Shyam, sit in a row with Ram and Shyam sitting next to each other?

The proof of the next corollary is immediate from the above example and hence the proof is omitted.

Corollary 1.1.6 Note that if $m = n$, we get the number of PERMUTATIONS or the number of ONE-TO-ONE, ONTO functions $f : M \rightarrow M$. Therefore, the number of permutations of the set $\{a_1, a_2, \dots, a_m\}$ is $m!$, called “ m -factorial”.

Corollary 1.1.7 Let N be a finite set consisting of n elements. Then what is the number of distinct subsets of size $0 \leq k \leq n$ of N .

Solution: Fix a subset K of N of size k . Then there are $k!$ functions $f : \{1, 2, \dots, k\} \rightarrow K$ that are one-to-one. Also, any one-to-one function $f : \{1, 2, \dots, k\} \rightarrow N$ gives rise to the set $\text{Im}(f) = f(\{1, 2, \dots, k\})$, which is a subset of N of size k . Thus, we have the following:

$$\begin{aligned} n \cdot (n - 1) \cdots (n - k + 1) &= \text{Number of one-to-one functions } f : \{1, 2, \dots, k\} \rightarrow N \\ &= k! \times \text{Number of subsets of size } k \text{ of } N. \end{aligned}$$

Hence,

$$\text{Number of subsets of size } k \text{ of } N = \frac{n \cdot (n - 1) \cdots (n - k + 1)}{k!}, \quad \text{denoted } \binom{n}{k}.$$

Remark 1.1.8 1. The number $\binom{n}{k} = \frac{n!}{k!(n-k)!}$ is a positive integer as this equals “Number of subsets of size k of a set consisting of n elements”.

2. The numbers $\binom{n}{k}$ are called BINOMIAL COEFFICIENTS as they appear in the expansion of $(x+y)^n$ which equals $\sum_{k=0}^n \binom{n}{k} x^k y^{n-k}$.

3. As soon as we have obtained a subset K of N with $|K| = k$, we have also obtained the subset \bar{K} (complement of the set K as a subset of N) of N of size $n - k$ and hence

$$\binom{n}{k} = \binom{n}{n-k}.$$

Exercise 1.1.9 1. How many ways are there to pick 5 girls from 6 girls?

2. How many ways are there to pick 2 students from 5 boys and 3 girls?

3. How many ways are there to pick 7 students from a class having 7 girls and 8 boys?

4. How many ways are there to select a committee of 5 from 11 teachers?

5. How many ways are there to pick a Calculus book, a Geometry book and an Algebra book from 3 Calculus books, 4 Geometry books and 5 Algebra books? The books are distinguishable.

6. How many ways are there to arrange the 5 letters of the word ABCDD?

7. How many ways are there to arrange the 5 letters of the word AAADD?

8. How many ways are there to arrange the letters of the word MATHEMATICS?

9. How many ways are there to arrange the letters of the word MISSISSIPPIMISSOURI?

10. How many ways are there for John to invite some of his 10 friends to dinner, if at least 1 of the friends is invited? Hint: Has it got to do with all subsets of 10?

Example 1.1.10 If $|M| = m$ and $|N| = n$ then what is the total number of onto functions $f: M \rightarrow N$?

Solution: Observe that the condition

$$f \text{ is onto} \Leftrightarrow \text{For all } y \in N \text{ there exists } x \in M \text{ such that } f(x) = y.$$

Therefore, if $m < n$, then the number such functions is 0. So, let us assume that $m \geq n$. Also, if $m = n$, then every onto function is also one-to-one and hence the number of such functions is $m! = n!$. Therefore, we assume that $m > n$.

Before we proceed with the solution, we need to digress a little to what is called a partition of a set.

Definition 1.1.11 *A partition of a finite set A into m -parts is a family of non-empty subsets A_1, A_2, \dots, A_m of A such that*

1. $A_i \cap A_j = \emptyset$ for all $1 \leq i \neq j \leq m$, and
2. $\bigcup_{i=1}^m A_i = A$.

Example 1.1.12 *The partitions of the set $A = \{a, b, c, d\}$ into 2-parts are*

$$a|bcd, \quad b|acd, \quad c|abd, \quad d|abc, \quad a, b|c, d, \quad a, c|b, d \quad \text{and} \quad a, d|b, c,$$

where the term $c|a, b, d$ represents the partition $A_1 = \{c\}$ and $A_2 = \{a, b, d\}$.

Definition 1.1.13 *Let $|A| = m$. Then the number of partitions of the set A into n -parts is denoted by $S(m, n)$, and is called the Stirling number of the second kind.*

Remark 1.1.14 *Consider the following problem:*

In how many ways can m **distinguishable** balls be put into n **indistinguishable** boxes with the restriction that no box is empty?

Note that the restriction “that no box is empty” forces us to look at the partition of a set consisting of m elements (as balls are distinguishable) into n parts (the boxes are indistinguishable). So, the answer to this question is just $S(m, n)$.

An inductive method to calculate the Stirling numbers of second kind is given in Eq. (1.1.2). Now, let us come back to the study of “onto functions”. Consider the following example.

Example 1.1.15 *Let $f : \{a, b, c, d\} \longrightarrow \{1, 2\}$ be an onto function given by*

$$f(a) = f(b) = f(c) = 1 \quad \text{and} \quad f(d) = 2.$$

Then this onto function, gives a partition $A_1 = \{a, b, c\}$ and $A_2 = \{d\}$ of the set $\{a, b, c, d\}$ into 2-parts. Also, given a partition $A_1 = \{a, d\}$, $A_2 = \{b, c\}$ of $\{a, b, c, d\}$ into 2-parts, we get the two onto functions $f, g : \{a, b, c, d\} \longrightarrow \{1, 2\}$ given by

$$f(a) = f(d) = 1, \quad f(b) = f(c) = 2 \quad \text{and} \quad g(a) = g(d) = 2, \quad g(b) = g(c) = 1.$$

Thus, we observe the following:

any onto function $f : M \longrightarrow N$ gives a partition and a one-to-one function from the partition (as a single element set) to $N = \{b_1, b_2, \dots, b_n\}$. That is, for $1 \leq j \leq n$, the sets

$f^{-1}(b_j) = \{a_i \in M : f(a_i) = b_j\}$ give a partition of M and each element of $f^{-1}(b_\ell)$ is mapped to b_ℓ , for $\ell = 1, 2, \dots, n$.

Conversely, each onto function $f : M \rightarrow N$ is completely determined by

- a partition of M into $n = |N|$ parts, and
- a one-to-one function from the partition (as a single element set) to the set N .

Hence, the answer to the question raised in Example 1.1.10 is

$$\begin{aligned} \text{Number of onto functions } f : M \rightarrow N \\ &= \text{Number of one-to-one functions } f : K \rightarrow N \\ &\quad \times \text{Number of partitions of the set } M \text{ into } n\text{-parts} \\ &= n! S(m, n). \end{aligned} \tag{1.1.1}$$

Remark 1.1.16 *Note that the question If $|M| = m$ and $|N| = n$ then what is the total number of onto functions $f : M \rightarrow N$? is same as the following question:*

In how many ways can m **distinguishable** balls be put into n **distinguishable** boxes with the restriction that no box is empty.

The following conventions are in order

$$\begin{aligned} 0! &= 0_{(0)} = 1, \quad 0^0 = 1, \quad n_{(0)} = 1 \text{ for all } n \geq 1, \quad 0_{(m)} = 0 \text{ for } m \neq 0, \\ S(n, 0) &= 0 \text{ for all } n \geq 1, \quad S(0, 0) = 1, \quad S(n, m) = 0 \text{ whenever } n < m \text{ and} \\ \binom{n}{k} &= 0 \text{ whenever } k > n. \end{aligned}$$

We end this section with the following exercises.

Exercise 1.1.17 1. For $n \geq r$, prove the following results about Binomial coefficients.

(a) **Pascal's Identity:** $\binom{n}{r} = \binom{n-1}{r} + \binom{n-1}{r-1}$.

(b) $k \binom{n}{k} = n \binom{n-1}{k-1}$.

(c) $\binom{k}{\ell} \binom{n}{k} = \binom{n}{\ell} \binom{n-\ell}{k-\ell}$.

(d) $\sum_{k=\ell}^n \binom{k}{\ell} \binom{n}{k} = \binom{n}{\ell} 2^{n-\ell}$.

(e) $\binom{n+r+1}{r} = \sum_{\ell=0}^r \binom{n+\ell}{\ell}$.

(f) $\binom{n+1}{r+1} = \sum_{\ell=r}^n \binom{\ell}{r}$.

2. Let X be a non-empty set. Suppose X_o and X_e , respectively, denote the set of all even and odd subsets of X . Describe a bijection to prove that $|X_o| = |X_e|$.
3. In how many ways can m **distinguishable** balls be put into n **indistinguishable** boxes?
4. Count the number of total functions $f : M \rightarrow N$ in two ways to prove that

$$n^m = \sum_{k=0}^m \binom{n}{k} k! S(m, k). \quad (1.1.2)$$

The Eq. (1.1.2) can be used recursively to calculate the values of $S(m, k)$. Use this to show $S(5, 1) = 1$, $S(5, 2) = 15$, $S(5, 3) = 25$, $S(5, 4) = 10$, $S(5, 5) = 1$. Can you think of a recurrence relation to get the values of $S(n, k)$'s?

5. For a positive integer n , let $b(n)$ denote the number of partitions of the set $\{1, 2, \dots, n\}$. Then $b(n)$ is called the n^{th} Bell number. So, by definition, it follows that $b(n) = \sum_{m=0}^n S(n, m)$. Find a recursive method for calculating the values of Bell numbers.
6. Count the number of functions $f : M \rightarrow N$ with $|M| = m$ and $|N| = n + 1$ in two ways to obtain

$$(n + 1)^m = \sum_{k=0}^m \binom{m}{k} n^k.$$

7. Suppose 13 people get on the lift at level **0**. suppose the lift stops at the levels **1, 2, 3, 4** and **5**. If all the people get down at some level, calculate the number of ways they can get down so that **at least one person gets down at each level**.
8. A function $f : N \rightarrow N$ is said to be **IDEMPOTENT** if $f(f(x)) = f(x)$ for all $x \in N$. If $|N| = n$, prove that the number of such functions equals $\sum_{k=1}^n k^{n-k} \binom{n}{k}$.
9. How many 7-letter words have 3 A's and 4 B's?
10. How many n -letter words have r A's and $n - r$ B's?
11. In how many ways can we arrange 3 girls and 4 boys?
12. In how many ways can we arrange 7 persons?
13. In how many ways can we arrange n persons?
14. In how many ways can we select r persons from n persons?
15. In how many ways can we select r distinguishable objects from n distinguishable objects when $n \geq r$?

16. How many ways are there to distribute 20 distinguishable toys among 4 children so that each children gets the same number of toys?
17. In how many ways can we partition 18 persons into study groups of 5, 6, and 7?
18. Let $X = \{1, 2, \dots, n\}$. A function $f : X \rightarrow X$ is said to be k -injective ($1 \leq k \leq n$), if there exists $S \subseteq X$ with $|S| = k$, such that the function restricted with domain as S is injective. For example, the permutations on the set X are the functions that are n -injective. Determine the number of functions that are EXACTLY k -injective.

2 Indistinguishable Objects

Example 1.2.1 1. How many words are possible using 3 A's and 6 B's?

Solution: We have already seen this problem and the answer is $\binom{9}{3}$.

2. How many sequences can be obtained that has 3 + 's and 6 1's?

Solution: Note that this problem is same as Example 1.2.1.1, except that A has been replaced by + and B has been replaced by 1. So, the answer remains the same.

3. How many solutions are there to the equation $x_1 + x_2 + x_3 + x_4 = 6$, where each $x_i \in \mathbb{Z}$ and $0 \leq x_i \leq 6$.

Solution: We will show that this problem is same as Example 1.2.1.1.

Take a sequence, say +111 + 1 + 11 of 3 + 's and 6 1's. Then this sequence can be written as $0 + 3 + 1 + 2$ and therefore gives rise to the solution $x_1 = 0, x_2 = 3, x_3 = 1$ and $x_4 = 2$ for the given equation.

In the same way, a solution, say $x_1 = 5, x_2 = 0, x_3 = 0$ and $x_4 = 1$ of the given equation gives rise to a sequence 11111 + + + 1 of 3 + 's and 6 1's.

Thus the total number of solutions is

$$\binom{9}{3} = \binom{9}{6} = \binom{6 + (4 - 1)}{6}.$$

We now generalize this example to a general case.

Example 1.2.2 1. How many words are possible using $n - 1$ A's and m B's?

Solution: We have already seen this problem and the answer is $\binom{n-1+m}{m}$.

2. How many sequences can be obtained that has $n - 1$ + 's and m 1's?

Solution: Note that this problem is same as Example 1.2.2.1, except that A has been replaced by + and B has been replaced by 1. So, the answer remains the same.

3. How many solutions are there to the equation $x_1 + x_2 + \cdots + x_n = m$, where each $x_i \in \mathbb{Z}$ and $0 \leq x_i \leq m$.

Solution: As the Example 1.2.1.3 shows, this problem is same as Example 1.2.2.1.

Thus the total number of solutions is

$$\binom{n-1+m}{m} = \binom{n-1+m}{n-1} = \binom{m + ((n) - 1)}{m}.$$

Remark 1.2.3 1. Observe that a solution of the equation $x_1 + x_2 + \cdots + x_n = m$ in nonnegative integers is same as the following problem:

“Suppose there are n boxes, numbered $1, 2, \dots, n$ and each of them contains m or more **indistinguishable** balls. Then find the number of ways of selecting m balls from the n boxes.”

Here the $m-1$'s are playing the role of the m indistinguishable balls and the x_i 's for $1 \leq i \leq n$ are playing the role of the n distinguishable boxes. So, the answer to this problem is also $\binom{n-1+m}{m}$.

2. The above problem is also same as the problem

“In how many ways can m **indistinguishable** balls be put into n **distinguishable** boxes.”

Exercise 1.2.4 1. How many 4-letter words (with repetition) are there with the letters in alphabetical order?

2. In how many ways can m **indistinguishable** balls be put into n **distinguishable** boxes with the restriction that no box is empty.
3. How many 26-letter permutations of the alphabet have no 2 vowels together?
4. How many 26-letter permutations of the alphabet have at least two consonants between any two vowels?
5. How many ways can 10 men and 7 women be seated in a row with no 2 women next to each other?
6. How many ways can 8 persons, including Ram and Shyam, sit in a row with Ram and Shyam not sitting next to each other?
7. How many arrangements of the letters of RECURRENCERELATION have no 2 vowels adjacent?
8. How many arrangements of the letters of RECURRENCERELATION have the vowels in alphabetical order?

9. How many nonnegative integer solutions are there to the equation

$$x_1 + x_2 + \cdots + x_5 = 67?$$

10. How many positive integer solutions are there to the equation

$$x_1 + x_2 + \cdots + x_5 = 67?$$

11. How many nonnegative integer solutions are there to the inequality

$$x_1 + x_2 + \cdots + x_5 < 68?$$

12. With repetition not allowed and order counting, how many ways are there to select r things from n distinguishable things?

13. With repetition allowed and order counting, how many ways are there to select r things from n distinguishable things?

14. With repetition not allowed and order not counting, how many ways are there to select r things from n distinguishable things?

15. With repetition allowed and order not counting, how many ways are there to select r things from n distinguishable things?

2.A Partitions

In the first chapter, we looked at the partition of a set consisting of m elements into n parts. We will now study the partition of a number m into n parts.

Definition 1.2.5 1. A partition of a positive integer m into n parts, is a collection of positive numbers $x_1 \geq x_2 \geq \cdots \geq x_n \geq 1$ such that $\sum_{k=1}^n x_k = m$.

The number of partitions of a positive integer m into n parts is denoted by $\Pi(m, n)$.

2. A partition of a positive integer m is a collection of positive integers $x_1 \geq x_2 \geq \cdots \geq x_k \geq 1$, $1 \leq k \leq m$ such that $\sum_{i=1}^k x_i = m$. This number is denoted by $\Pi(m)$. So,

$$\Pi(m) = \sum_{k=1}^m \Pi(m, k).$$

Now suppose that we have got $2m$ indistinguishable balls and we need to put all of them in exactly m indistinguishable boxes with no box empty. As defined above, this number is $\Pi(2m, m)$. We can solve the same problem as follows:

As a first step, we put exactly one ball into all the m boxes. At this stage, we are left with m balls and we just need to put them in any number of boxes (all the boxes are already non-empty). This number is $\Pi(m)$. So, we see that $\Pi(m) = \Pi(2m, m)$.

For example, partitions of 7 into 4 parts are given by

$$4 + 1 + 1 + 1, \quad 3 + 2 + 1 + 1, \quad 2 + 2 + 2 + 1.$$

So, $\Pi(7, 4) = 3$. It can be checked that $\Pi(7, 1) = 1$, $\Pi(7, 2) = 3$, $\Pi(7, 3) = 4$ and so on and therefore, $\Pi(7) = 15$. Note that the calculation of number of partitions of a positive integer m into n parts is equivalent to the following problem about balls.

Example 1.2.6 1. In how many ways can m **indistinguishable** balls be put into n **indistinguishable** boxes with the restriction that no box is empty?

Solution: As we are talking about indistinguishable balls, we are just looking at the number of balls in each box with no box empty. Also, each box is indistinguishable and hence we can arrange the balls into non-increasing order. Hence, we have the answer as $\Pi(m, n)$.

2. In how many ways can m **indistinguishable** balls be put into n **indistinguishable** boxes?

Solution: Just put exactly one ball in each box. Then the given question is same as “In how many ways can $m + n$ **indistinguishable** balls be put into n **indistinguishable** boxes?” So, the answer is $\Pi(m + n, n)$.

2.B Miscellaneous Exercises

1. How many ways are there to arrange the letters in *ABRACADABRAARCADA* with the first *A* preceding the first *B*?
2. How many ways are there to arrange the letters in *ABRACADABRAARCADA* with the first *A* preceding the first *B* and with the first *D* preceding the first *C*?
3. How many ways are there to distribute 60 balls to 5 persons if Ram and Shyam together get no more than 30 and Mohan gets at least 10?
4. How many ways can we pick 20 letters from 10 *A*'s, 15 *B*'s and 15 *C*'s?
5. How many ways are there to select 7 integers from the set $\{1, 2, 3, \dots, 50\}$ such that the positive difference between any two of the 7 integers is at least 3?
6. How many 10-element subsets of the alphabet have a pair of consecutive letters?
7. Prove that there exists a bijection between any two of the following sets.

- (a) The set of words of length n on an alphabet consisting of m letters.
 - (b) The set of maps of an n -set into a m -set.
 - (c) The set of distributions of n distinct objects into m distinct boxes.
 - (d) The set of n -tuples on m letters.
8. Prove that there exists a bijection between any two of the following sets.
- (a) The set of n letter words with distinct letters out of an alphabet consisting of m letters.
 - (b) The set of one-one functions from an n -set into a m -set.
 - (c) The set of distributions of n distinct objects into m distinct boxes, subject to “if an object is put in a box, no other object can be put in the same box”.
 - (d) The set of n -tuples on m letters, without repetition.
 - (e) The set of permutations of m symbols taken n at a time.
9. Prove that there exists a bijection between any two of the following sets.
- (a) The set of increasing words of length n on m ordered letters.
 - (b) The set of distributions on n non-distinct objects into m distinct boxes.
 - (c) The set of combinations of m symbols taken n at a time with repetitions permitted.
10. Determine the number of ways of distributing n distinct objects into m distinct boxes so that objects in each box are arranged in a definite order.

3 Round Table Configurations

We now differentiate between arrangements in a row and arrangements at a round table. The basic difference is:

If there are 4 chairs at a round table then the arrangements $ABCD$ and the arrangement $BCDA$ are the same. So, to get distinct arrangements at a round table, we fix an object and assign it the number 1 position and study the distinct arrangement of the other $n - 1$ objects.

Example 1.3.1 1. *How many ways can 8 persons be seated at a round table?*

Solution: Method 1: *Note that among the 8 people, say P_1 , the first person is assigned the number 1 position and the rest 7 persons can be arranged in $7!$ ways. So, the total number of arrangements is $7!$.*

Method 1: *The total number of arrangements of 8 persons if they are to be seated in a row is $8!$. Since the cyclic arrangement $A_1A_2 \dots A_8$ is same as the arrangement $A_8A_1A_2 \dots A_7$ and so on, we need to divide the number $8!$ by 8 to get the actual number as $7!$.*

2. *How many ways can 8 couples be seated in a row if each couple is seated together?*

Solution: *A couple can be thought of as one cohesive group (they are to be seated together) to get $8!$ arrangements. But a couple can sit either as “wife and husband” or “husband and wife”. So, the total number of arrangements is $2^8 8!$.*

3. *How many ways can 8 couples be seated in a round table if each couple is seated together?*

Solution: *Use Examples 1.3.1.1 and 1.3.1.2 to get the answer as $2^8 7!$.*

1. How many ways can 5 men and 7 women be seated at a round table with no 2 men next to each other?
2. How many ways can 10 men and 7 women sit at a round table so that no 2 women are next to each other?
3. How many ways can 8 persons, including Ram and Shyam, sit at a round table with Ram and Shyam not sitting next to each other?
4. How many ways are there to select 6 men from 25 men sitting at a round table if no adjacent men are chosen?

4 Lattice Paths

Consider a lattice of integer lines in the plane. Let (m, n) , $m, n \in \mathbb{N}$ be a fixed point on this lattice. Define an INCREASING PATH from the point $(0, 0)$ to (m, n) to be an ordered set of edges e_1, e_2, \dots, e_k from the lattice having the following properties:

1. e_i has a vertex common with e_{i-1} , $2 \leq i \leq k$,
2. if the edge e_i is formed with the coordinates (a_1, b_1) and (a_2, b_2) , then
 - (a) either $a_1 = a_2$ and $b_2 = b_1 + 1$
 - (b) or $b_1 = b_2$ and $a_2 = a_1 + 1$.

That is, the movement on the lattice is either to the RIGHT or UP (see Figure 1.1). The question is the following:

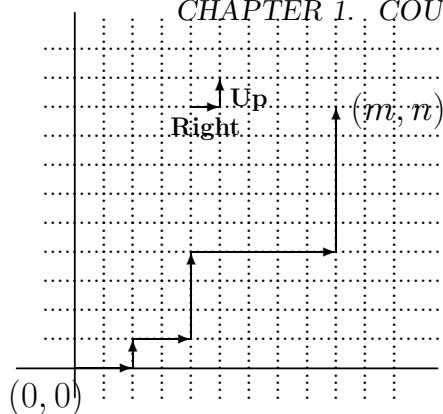

Figure 1.1:

Example 1.4.1 1. How many distinct increasing paths are there from the point $(0,0)$ to (m,n) .

Solution: Note that each path must increase in its X -coordinate m times and must increase in Y -coordinate exactly n times. That is, each path is a sequence of m R 's (for $RIGHT$) and n U 's (for UP). So, we need to find m places for the R 's among the $m+n$ places (R and U together). Thus the answer is $\binom{m+n}{m}$.

2. Interpret the following result about Binomial Coefficients:

$$\sum_{\ell=0}^m \binom{n+\ell}{\ell} = \binom{n+m+1}{m}.$$

Solution: Consider the points $(0, n+1)$, $(1, n+1)$, $(2, n+1)$, \dots , $(m, n+1)$. As soon as a path reaches one of these points, its route to the point $(m, n+1)$ is completely determined. That is, in counting the number of paths from $(0,0)$ to $(m, n+1)$, the number of paths from $(0,0)$ to $(\ell, n+1)$ for $0 \leq \ell \leq m-1$ get counted again. So, we should not look at the paths from $(0,0)$ to $(\ell, n+1)$. In place of that, we need to look at paths from $(0,0)$ to (ℓ, n) for $0 \leq \ell \leq m$ and then take an upward movement as the next move and then go right to end at the point $(m, n+1)$. This will give us all distinct required paths. Also, the number of paths from $(0,0)$ to (ℓ, n) for $0 \leq \ell \leq m$ is $\binom{n+\ell}{\ell}$. Hence we get the required answer.

3. Find the number of paths from $(0,0)$ to (n,n) that do not cross the line $Y = X$ (see Figure 1.2).

Solution: As we are not allowed to cross the line $Y = X$, the first move has to be along the X -axis. So, we are basically looking at all paths from $(1,0)$ to (n,n) that does not cross the line $Y = X$.

But from Example 1, we know that the total number of paths from $(1,0)$ to (n,n) is $\binom{2n-1}{n}$. So, we need to subtract the number of those paths, from $(1,0)$ to (n,n) , that **cross** the line $Y = X$.

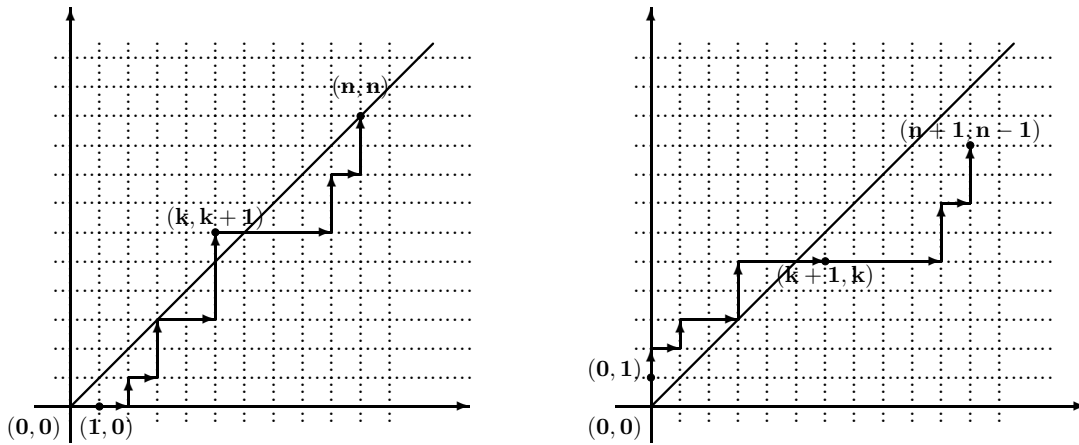

Figure 1.2:

Suppose P is a path from $(1,0)$ to (n,n) that crosses the line $Y = X$ at the point (k,k) for the first time, $1 \leq k \leq n - 1$. Then we make the following claim.

Claim: For each such path P , from $(1,0)$ to (n,n) that crosses the line $Y = X$, there is an increasing path from $(0,1)$ to $(n + 1, n - 1)$ and vice-versa.

As the path P crosses the line $Y = X$ at the point (k,k) for the first time, we get a sequence of $(k - 1)$ R 's and $(k + 1)$ U 's corresponding to the path P till the first $(2k)^{th}$ stage and in the remaining portion, the sequence has $(n - k)$ R 's and $(n - k - 1)$ U 's. Also, this sequence till the $(2k)^{th}$ stage has the following property:

- (the number of R 's till the $(2k - 1)^{th}$ stage) \geq (the number of U 's); and
- at the $(2k)^{th}$ stage the sequence has a U .

This sequence can be related with another sequence of $(k + 1)$ R 's and $(k - 1)$ U 's by interchanging the R 's and U 's till the first $(2k)^{th}$ stage in path P . After this replacement, the path P changes to an increasing path from $(0,1)$ to $(n + 1, n - 1)$, as now the number of U 's and R 's are $(n - 2)$ and $(n + 1)$, respectively.

Also, each path from $(0,1)$ to $(n + 1, n - 1)$ has $(n + 1)$ R 's and $(n - 2)$ U 's. So, in any such sequence a stage comes where the number of R 's exceeds the number of U 's by 2. Let at the $(2k)^{th}$, the number of R 's exceed the number of U 's by 2 for the first time ($k \geq 1$). Then there are $(k + 1)$ R 's and $(k - 1)$ U 's till the first $(2k)^{th}$ stage and $(n - k)$ R 's and $(n - 1 - k)$ U 's in the remaining portion of the sequence. We can replace the occurrence of the R 's and U 's in the first $(2k)^{th}$ stage to get a sequence of $(n - 1)$ R 's and n U 's which corresponds to an increasing path from $(1,0)$ to (n,n) that crosses the line $Y = X$. This completes the proof of the claim.

But the number of increasing paths from $(0, 1)$ to $(n + 1, n - 1)$ is $\binom{2n-1}{n+1}$. Hence, we need to subtract this number from $\binom{2n-1}{n}$. Hence, the number of increasing paths from $(0, 0)$ to (n, n) that do not cross the line $Y + X$ is

$$\binom{2n-1}{n} - \binom{2n-1}{n+1} = \frac{1}{n+1} \binom{2n}{n}.$$

This number is popularly known as the $n - 1^{\text{th}}$ CATALAN NUMBER.

Remark 1.4.2 Catalan numbers appear at lots of combinatorial places. For example, look at the following problems:

1. Suppose in an election two candidates A and B get equal number of votes, say $n + 1$. It was found that during the counting of votes the candidate A was always ahead of the candidate B . Find the number of ways in which such an instance can arise.
2. Suppose, we need to add $n + 1$ given numbers, say a_1, a_2, \dots, a_{n+1} . In how many ways can this addition be performed?
3. In how many ways can a convex n -gon be divided into triangles by its diagonals such that no two diagonals intersect inside the n -gon?
4. Determine the number of binary trees on $2n + 1$ vertices.
5. Determine the number of rooted trees on $n + 1$ vertices.
6. Determine the number of Dyck paths from the vertex $(0, 0)$ to $(2n, 0)$ (A Dyck path is a movement on an integer lattice where each step is $(1, 1)$ -North East or $(1, -1)$ -South East).
7. Determine the number of n nonintersecting chords joining $2n$ points on the circumference of a circle.
8. How many ways are there to connect $2n$ points in the plane lying on a horizontal line by n nonintersecting arcs, each arc connecting two of the points and lying above the points.
9. How many sequences of integers exist that satisfy $1 \leq a_1 \leq a_2 \leq \dots \leq a_n$, $a_i \leq i$ for $1 \leq i \leq n$.
10. How many sequences a_1, a_2, \dots, a_n of integers exist such that $a_i \geq -1$, all partial sums are nonnegative and $a_1 + a_2 + \dots + a_n = 0$.

For more literature on Catalan Numbers, see the exercises on Catalan and Related Numbers, in the book [7] by Stanley.

The following article has been taken from Paper [1].

Let A_n denote the set of all lattice paths from $(0, 0)$ to (n, n) and let $B_n \subset A_n$ denote the set of all lattice paths from $(0, 0)$ to (n, n) that does not cross the line $Y = X$. Then we have observed that $(n + 1) \cdot |B_n| = |A_n|$. The question arises:

can we find a partition of the set A_n into $(n + 1)$ -parts, say $S_0, S_1, S_2, \dots, S_n$ such that $S_0 = B_n$ and $|S_i| = |S_0|$ for $1 \leq i \leq n$.

The answer is in affirmative. Observe that any path from $(0, 0)$ to (n, n) has n right moves. So, the path is specified as soon as we know the successive right moves R_1, R_2, \dots, R_n , where R_i equals ℓ if and only if $R - i$ lies on the line $Y = \ell$. For example, in Figure 1.2,

$$R_1 = 0, R_2 = 0, R_3 = 1, R_4 = 2, \dots$$

These R_i 's satisfy

$$0 \leq R_1 \leq R_2 \leq \dots \leq R_n \leq n. \quad (1.4.1)$$

That is, any element of A_n can be represented by an ordered n -tuple (R_1, R_2, \dots, R_n) satisfying Equation (1.4.1). Conversely, any ordered n -tuple (R_1, R_2, \dots, R_n) satisfying Equation (1.4.1) corresponds to a lattice path from $(0, 0)$ to (n, n) . Note that among the above n -tuples, the tuples that satisfy

$$R_i \leq i - 1, \quad \text{for } 1 \leq i \leq n \quad (1.4.2)$$

are elements of B_n and vice-versa. Now, for $0 \leq k \leq n$, we consider the following $n + 1$ maps $f_k : B_n \rightarrow A_n$ given by

$$f_k((R_1, R_2, \dots, R_n)) = (t_1, t_2, \dots, t_n)$$

where (t_1, t_2, \dots, t_n) is an increasing ordering of the n -tuple

$$(R_1 \oplus_{n+1} k, R_2 \oplus_{n+1} k, \dots, R_n \oplus_{n+1} k) \quad \text{with } \oplus_{n+1} \text{ denoting the addition modulo } n + 1.$$

For each fixed $k, 0 \leq k \leq n$, let S_k denote the image of the function f_k . Then the readers are requested to prove the following exercise. These exercises imply that we have obtained the required partition of the set A_n .

Exercise 1.4.3 1. For $k \neq 0$, S_k is distinct from B_n .

2. Not only the sets $S_0, S_1, S_2, \dots, S_n$ are distinct but they are also disjoint.

3. For any two n -tuples R and R' in B_n , the n -tuples $f_k(R) \neq f_k(R')$ for $0 \leq k \leq n$.

4. Given any path $P \in A_n$, there exists a positive integer $k, 0 \leq k \leq n$ and a path $R \in B_n$ such that $f_k(R) = P$.

5. Describe a bijection to explain the equivalence for the following two statements:

(a) The number of solutions in non-negative integers to the system

$$x_0 + x_1 + x_2 + \cdots + x_k = n \quad \text{is} \quad \binom{n+k}{k}.$$

(b) The number of lattice paths from $(0, 0)$ to (n, k) is $\binom{n+k}{k}$.

6. Let X be a finite set. A function $f : X \rightarrow \mathbb{W}$ is called a multiset if $f(x)$ is finite for all $x \in X$. The number $f(x)$ is called the size of X and $\sum_{x \in X} f(x)$ is the size of the multiset. For example, if $X = a, b, c$ and $f(a) = 2, f(b) = 3, f(c) = 1$, then the corresponding multiset is $\{a, a, b, b, b, c\}$ and its size is 6.

If $|X| = n$, determine the number of multisets of size k .

7. Fix a positive integer n . A composition of n is an expression of n as a sum of positive integers. For example, if $n = 4$, then the distinct compositions are

$$4, \quad 3 + 1, \quad 1 + 3, \quad 2 + 2, \quad 2 + 1 + 1, \quad 1 + 1 + 2, \quad 1 + 2 + 1, \quad 1 + 1 + 1 + 1.$$

Let $S_k(n)$ denote the number of compositions of n into k parts. Then $S_1(4) = 1, S_2(4) = 3, S_3(4) = 3$ and $S_4(4) = 1$. Determine the number $S_k(n)$ for $1 \leq k \leq n$.

8. Construct a proof of $\binom{n}{0} + \binom{n}{1} + \cdots + \binom{n}{n} = 2^n$ using lattice paths.

9. Determine a closed form expression for $\sum_{\ell \geq 0} \binom{n}{\ell} S(\ell, k)$, where $S(n, k)$'s are the Stirling Numbers of second kind.

10. Let $S = \{1, 2, \dots, n\}$. Let $s(n, k)$ be the number of permutations of the set S into k disjoint cycles. Determine a recurrence relation that the numbers $s(n, k)$ satisfy. Also compute $\sum_{k \geq 0} s(n, k)x^k$.

5 Some Generalizations

1. Let n, k be non-negative integers with $0 \leq k \leq n$. Then the binomial coefficients, $\binom{n}{k}$, are defined as the number of ways of choosing a subset of size k from a set consisting of n elements. Also,

$$\binom{n}{k} = \frac{n!}{k!(n-k)!} = \frac{n \cdot (n-1) \cdots (n-k+1)}{k!}.$$

We are now ready to generalize the numbers $\binom{n}{k}$ even when $k > n$ and n itself need not be a non-negative integer. Also, we do it only when k is a non-negative integer. To do so, we define

$$\binom{n}{k} = \begin{cases} 0 & \text{if } k < 0 \\ \frac{n \cdot (n-1) \cdots (n-k+1)}{k!} & \text{if } k \in \mathbb{Z}, k \geq 0 \end{cases} \quad (1.5.3)$$

For example, using (1.5.3), we have

$$\binom{\frac{1}{2}}{k} = \frac{\frac{1}{2} \cdot \left(\frac{1}{2} - 1\right) \cdots \left(\frac{1}{2} - k + 1\right)}{k!} = \frac{1 \cdot (-1) \cdot (-3) \cdots (3 - 2k)}{2^k k!} = \frac{(-1)^{k-1} (2k-2)!}{2^{2k} (k-1)! k!}.$$

2. Let $n, m \in \mathbb{N}$. Recall the identity $n^m = \sum_{k=0}^m \binom{n}{k} k! S(m, k) = \sum_{k=0}^n \binom{n}{k} k! S(m, k)$ that was given in Exercise 1.1.17.4 (see Equation 1.1.2). We note that the above identity is same as the matrix product $X = AY$, where

$$X = \begin{bmatrix} 0^m \\ 1^m \\ 2^m \\ 3^m \\ \vdots \\ n^m \end{bmatrix}, \quad A = \begin{bmatrix} \binom{0}{0} & \binom{0}{1} & \binom{0}{2} & \binom{0}{3} & \cdots & \binom{0}{n} \\ \binom{1}{0} & \binom{1}{1} & \binom{1}{2} & \binom{1}{3} & \cdots & \binom{1}{n} \\ \binom{2}{0} & \binom{2}{1} & \binom{2}{2} & \binom{2}{3} & \cdots & \binom{2}{n} \\ \binom{3}{0} & \binom{3}{1} & \binom{3}{2} & \binom{3}{3} & \cdots & \binom{3}{n} \\ \vdots & \vdots & \vdots & \ddots & \cdots & \vdots \\ \binom{n}{0} & \binom{n}{1} & \binom{n}{2} & \binom{n}{3} & \cdots & \binom{n}{n} \end{bmatrix}, \quad \text{and } Y = \begin{bmatrix} 0! S(m, 0) \\ 1! S(m, 1) \\ 2! S(m, 2) \\ \vdots \\ n! S(m, n) \end{bmatrix}.$$

Hence, if we know the inverse of the matrix A , we can write $Y = A^{-1}X$. Check that

$$A^{-1} = \begin{bmatrix} \binom{0}{0} & \binom{0}{1} & \binom{0}{2} & \binom{0}{3} & \cdots & \binom{0}{n} \\ -\binom{1}{0} & \binom{1}{1} & \binom{1}{2} & \binom{1}{3} & \cdots & \binom{1}{n} \\ \binom{2}{0} & -\binom{2}{1} & \binom{2}{2} & \binom{2}{3} & \cdots & \binom{2}{n} \\ -\binom{3}{0} & \binom{3}{1} & -\binom{3}{2} & \binom{3}{3} & \cdots & \binom{3}{n} \\ \vdots & \vdots & \vdots & \ddots & \cdots & \vdots \\ (-1)^{n+1} \binom{n}{0} & (-1)^{n+2} \binom{n}{1} & (-1)^{n+2} \binom{n}{2} & (-1)^{n+3} \binom{n}{3} & \cdots & \binom{n}{n} \end{bmatrix}.$$

This gives us a way to calculate the Stirling numbers of second kind as a function of binomial coefficients.

3. The above principle also implies that whenever we have $a(n) = \sum_{k \geq 0} \binom{n}{k} b(k)$, we can write $b(n) = \sum_{k \geq 0} (-1)^k \binom{n}{k} a(k)$.
4. We end this chapter with an example which has a history (see [3]) of being solved by many mathematicians such as Montmort, N. Bernoulli and de Moivre. The ideas we use here was proposed by Euler.

Example 1.5.4 *On a rainy day, n students leave their umbrellas (which are indistinguishable) outside their examination room. What is the probability that no student collects the correct umbrella when they finish the examination? This problem is generally known by the DERANGEMENT PROBLEM.*

Solution: Let the students be numbered $1, 2, \dots, n$ and suppose that the i^{th} student has the umbrella numbered i , $1 \leq i \leq n$. So, we are interested in the number of permutations of the set $\{1, 2, \dots, n\}$ such that the number i is not at the i^{th} position. Let D_n represent the number of derangements. Then it can be checked that $D_2 = 1$ and $D_3 = 2$. They correspond the permutations 21 for $n = 2$ and 231, 312 for $n = 3$. We will try to find a relationship of D_n with D_i , for $1 \leq i \leq n - 1$.

Let us have a close look at the required permutations. We note that n should not be placed at the n^{th} position. So, n has to appear some where between 1 and $n - 1$. That is, for some i , $1 \leq i \leq n - 1$

- (a) n appears at the i^{th} position and i appears at the n^{th} position, or
- (b) n appears at the i^{th} position and i does not appear at the n^{th} position.

Case (4a): For $1 \leq i \leq n - 1$, the position of n and i is fixed and the remaining numbers j for $j = 1, 2, \dots, i - 1, i + 1, \dots, n - 1$ should not appear at the j^{th} place. So, for the remaining numbers, we need to look at the derangement of $n - 2$ numbers. That is, the first case gives us $(n - 1)D_{n-2}$ (D_{n-2} for the derangement of $n - 2$ numbers and $(n - 1)$ because we have $(n - 1)$ choices for the number i).

Case (4b): For $1 \leq i \leq n - 1$, the position of n is at the i^{th} place but i is not placed at the n^{th} position. So, we need to look at the following problem.

Consider the numbers $1, 2, \dots, n - 1$. We have to arrange these numbers at the places $1, 2, \dots, i - 1, i + 1, \dots, n$ such that for $j \neq i$, j is not to be placed at the j^{th} position and the number i is not to be placed at the n^{th} position. So, if we rename the numbers and position properly then we have to look at the permutation of the numbers a_1, a_2, \dots, a_{n-1} with the condition that a_i does not appear at the i^{th} position. Thus, this case leads us to the number $(n - 1)D_{n-1}$.

Hence, $D_n = (n - 1)D_{n-1} + (n - 1)D_{n-2}$. Or equivalently,

$$D_n - nD_{n-1} = -(D_{n-1} - (n - 1)D_{n-2}) = (-1)^2(D_{n-2} - (n - 2)D_{n-3}) = \dots = (-1)^n.$$

Therefore, using $D_2 = 1$, we have

$$\begin{aligned}
 D_n &= nD_{n-1} + (-1)^n = n((n-1)D_{n-2} + (-1)^{n-1}) + (-1)^n \\
 &= n(n-1)D_{n-2} + n(-1)^{n-1} + (-1)^n \\
 &\quad \vdots \\
 &= n(n-1)\cdots 4 \cdot 3 D_2 + n(n-1)\cdots 4(-1)^3 + \cdots + n(-1)^{n-1} + (-1)^n \\
 &= n! \left(1 + \frac{-1}{1!} + \frac{(-1)^2}{2!} + \cdots + \frac{(-1)^{n-1}}{(n-1)!} + \frac{(-1)^n}{n!} \right).
 \end{aligned}$$

Notes: Most of the ideas for this chapter have come from the books [2], [4] and [5].

Chapter 2

Advanced Counting

1 Principle of Mathematical Induction

AXIOM:[Well Ordering Principle]

Every non-empty subset of positive integers contains a least element.

Theorem 2.1.5 (Principle of Mathematical Induction: Weak Form) *Let $P(n)$ be a statement about a positive integer n such that*

1. $P(1)$ is true,
2. If $P(k)$ is true then $P(k + 1)$ is true.

Then $P(n)$ is true for all positive integer n .

PROOF. On the contrary assume that there exists $n_0 \in \mathbb{N}$ such that $P(n_0)$ is false. Define a set

$$S = \{m \in \mathbb{N} : P(m) \text{ is false} \}.$$

Then $n_0 \in S$ and therefore $S \neq \emptyset$. So, by Well-Ordering Principle, S must have a least element, say N . By assumption $N \neq 1$ as $P(1)$ is true. Thus, $N \geq 2$, $N - 1 \in \mathbb{N}$. As $N - 1 < N$, the minimality of N gives, $P(N - 1)$ holds true. So, by the given Hypothesis 2, the truth of the statement $P(N - 1)$ implies that $P(N)$ is true. A contradiction. \square

Example 2.1.6 *Let $n \in \mathbb{N}$ and suppose we are given real numbers $a_1 \geq a_2 \geq \dots \geq a_n \geq 0$. Then*

$$\text{Arithmetic Mean (AM)} := \frac{a_1 + a_2 + \dots + a_n}{n} \geq \sqrt[n]{a_1 \cdot a_2 \cdot \dots \cdot a_n} =: \text{(GM) Geometric Mean.}$$

Solution: The result is clearly true for $n = 1, 2$. So, we assume the result holds for any collection of $n - 1$ non-negative real numbers.

The given condition implies that $a_1 - A, A - a_n \geq 0$. So, $(a_1 - A)(A - a_n) \geq 0$. That is, $A(a_1 + a_n) - A^2 \geq a_1 a_n$. Thus,

$$(a_1 + a_n - A)A \geq a_1 a_n. \quad (2.1.1)$$

Now consider the $n - 1$ numbers $a_2, a_3, \dots, a_{n-1}, a_1 + a_n - A$. Then

$$\text{AM} = \frac{a_2 + a_3 + \dots + a_{n-1} + (a_1 + a_n - A)}{n - 1} = \frac{(a_1 + a_2 + \dots + a_n) - A}{n - 1} = \frac{nA - A}{n - 1} = A$$

and

$$\text{GM} = \sqrt[n-1]{a_2 \cdot a_3 \cdot \dots \cdot a_{n-1} \cdot (a_1 + a_n - A)}.$$

Now by induction hypothesis,

$$A = \frac{a_2 + a_3 + \dots + a_{n-1} + (a_1 + a_n - A)}{n - 1} \geq \sqrt[n-1]{a_2 \cdot a_3 \cdot \dots \cdot a_{n-1} \cdot (a_1 + a_n - A)}.$$

Hence, $A^{n-1} \geq a_2 \cdot a_3 \cdot \dots \cdot a_{n-1} \cdot (a_1 + a_n - A)$. Or equivalently,

$$A^n \geq a_2 \cdot a_3 \cdot \dots \cdot a_{n-1} \cdot (a_1 + a_n - A)A.$$

Therefore, by using (2.1.1), the result follows.

Exercise 2.1.7 1. Prove that $1 + 2 + 3 + \dots + n = \frac{n(n+1)}{2}$.

2. Prove that $1 + 3 + 5 + \dots + (2n - 1) = n^2$.

3. Prove that $1^2 + 2^2 + 3^2 + \dots + n^2 = \frac{n(n+1)(2n+1)}{6}$.

4. Determine $1^4 + 2^4 + 3^4 + \dots + n^4$.

5. Determine $1 \cdot 2 + 2 \cdot 3 + 3 \cdot 4 + \dots + (n - 1) \cdot n$.

6. Determine $1 \cdot \binom{n}{1} + 2 \cdot \binom{n}{2} + 3 \cdot \binom{n}{3} + \dots + n \cdot \binom{n}{n}$.

7. Determine $1 \cdot 2 \cdot 3 + 2 \cdot 3 \cdot 4 + 3 \cdot 4 \cdot 5 + \dots + (n - 2) \cdot (n - 1) \cdot n$.

8. Prove that $n(n + 1)$ is even for all $n \in \mathbb{N}$.

9. Prove that 6 divides $n^3 - n$ for all $n \in \mathbb{N}$.

10. Let S be a finite set consisting of n elements, $n \geq 0$. Prove that S has exactly 2^n subsets.

11. Prove that $\binom{n}{0} + \binom{n}{2} + \dots + \binom{n}{n} = 2^n$ for all $n \in \mathbb{N}$.

12. Prove that $\sum_{k \geq 0} \binom{n}{2k} = \sum_{k \geq 0} \binom{n}{2k+1}$ for all $n \in \mathbb{N}$.
13. Let $w \neq 1$ be a cube root of unity. Determine $\sum_{k \geq 0} \binom{n}{3k}$ for all $n \in \mathbb{N}$.

Theorem 2.1.8 (Principle of Mathematical Induction: Strong Form) *Let $P(n)$ be a statement about a positive integer n such that*

1. $P(1)$ is true,
2. If $P(m)$ is true for all m , $1 \leq m < k$ then $P(k)$ is true.

Then $P(n)$ is true for all positive integer n .

PROOF. Let $Q(n)$ be the statement that $P(k)$ holds for all positive integers k with $1 \leq k \leq n$. We prove that $Q(n)$ holds for all positive integers n by weak-form of mathematical induction. This will give the required result as the statement $Q(n)$ holds true clearly implies that $P(n)$ also holds true.

As a first step, we see that $Q(1)$ is true follows from the first hypothesis ($P(1)$ is true). So, the first hypothesis of the weak-form of mathematical induction holds true. So, let us assume that $Q(k)$ holds true. We need to prove that $Q(k+1)$ holds true. This is equivalent to showing that $P(m)$ holds true for all m , $1 \leq m \leq k+1$.

The truth of the statement $P(m)$ holds true for all m , $1 \leq m \leq k$ follows from the assumption that $Q(k)$ holds true. So, by Hypothesis 2, $P(k+1)$ holds true. That is, we have shown that $P(m)$ holds true for all m , $1 \leq m \leq k+1$. Hence the result follows. \square

We state a corollary of the Theorem 2.1.8 without proof.

Corollary 2.1.9 (Principle of Mathematical Induction) *Let $P(n)$ be a statement about a positive integer n such that for some fixed positive integer n_0 ,*

1. $P(n_0)$ is true,
2. if $P(m)$ is true for all m , $n_0 \leq m < k$ then $P(k)$ is true.

Then $P(n)$ is true for all positive integer $n \geq n_0$.

Remark 2.1.10 (Pitfall) *Find the error in the following arguments:*

1. If a set of n balls contains a green ball then all the balls in the set are green.

Solution: If $n = 1$, we are done. So, let the result be true for any collection of $n = k$ balls in which there is a green ball. We will prove the result for $n = k + 1$.

From the $k+1$ balls, choose a collection of k balls that contains one green ball. By induction hypothesis, this collection has all green balls. Now remove one ball from this collection (observe that the ball removed is green as all balls are green by induction hypothesis) and put the ball which was left out. Now, in this new collection at least one ball was green and hence again by induction hypothesis, all the balls in this new collection are green. So, all the $k+1$ balls are green. Hence the result follows by induction hypothesis.

2. In any collection of n lines in a plane, no two of which are parallel, all the lines pass through a common point.

Solution: If $n = 1, 2$ then the result is easily seen to be true. So, let the result be true for any collection of $n = k$ lines no two of which are parallel. We will prove the result for a collection of $n = k + 1$ lines in which no two lines are parallel.

Let the $k+1$ lines in the plane be $\ell_1, \ell_2, \dots, \ell_{k+1}$. From this collection of lines, let us choose the subset $\ell_1, \ell_2, \dots, \ell_k$, consisting of k lines. By induction hypothesis, all the lines in this collection pass through the same point, say p , the point of intersection of the lines ℓ_1 and ℓ_2 . has all green balls. Now consider the collection $\ell_1, \ell_2, \dots, \ell_{k-1}, \ell_{k+1}$. This collection again consists of k lines and hence by induction hypothesis, all the lines pass through a common point. This common point is P itself, as P is the point of intersection of the lines ℓ_1 and ℓ_2 . Thus, by principle of mathematical induction the proof of our statement is complete.

3. Consider the polynomial $f(x) = x^2 - x + 41$. Check that for $1 \leq n \leq 40$, $f(n)$ is a prime number. Does this necessarily imply that $f(n)$ is prime for all positive integers n ?

2 Pigeonhole Principle

The pigeonhole principle states that *if there are $n + 1$ pigeons and n holes (boxes), then there is at least one hole (box) that contains two or more pigeons*. It can be easily verified that the pigeonhole principle is equivalent to the following statements:

1. If m pigeons are put into m pigeonholes, there is an empty hole if and only if there's a hole with more than one pigeon.
2. If n pigeons are put into m pigeonholes, where $n > m$, then there is a hole with more than one pigeon.
3. Let $|A|$ denote the number of elements in a finite set A . For two finite sets A and B , there exists a one to one and onto function $f : A \longrightarrow B$ if and only if $|A| = |B|$.

Remark 2.2.1 1. In some books, the pigeonhole principle is stated as follows: if there are n pigeons and m holes with $n > m$, then there is at least one hole that contains $\lceil \frac{n}{m} \rceil$ pigeons (recall that the expression $\lceil x \rceil$ stands for the smallest integer m such that $m \geq x$).

2. Dirichlet was the one who popularised this principle.

Example 2.2.2 1. Let a be an irrational number. Then there exist infinitely many rational numbers $s = \frac{p}{q}$ such that $|a - s| < \frac{1}{q^2}$.

PROOF. Let $N \in \mathbb{N}$. Without loss of generality, we assume that $a > 0$. By $\{\alpha\}$, we denote the fractional part of α . That is, $\{\alpha\} = \alpha - \lfloor \alpha \rfloor$.

Now, consider the fractional parts $\{0\}, \{a\}, \{2a\}, \dots, \{Na\}$ of the first $(N + 1)$ multiples of a . By the pigeonhole principle, two of these must fall into one of the N subintervals

$$[0, \frac{1}{N}), [\frac{1}{N}, \frac{2}{N}), \dots, [\frac{N-1}{N}, 1)$$

of $[0, 1)$. That is, there exist integers u, v and w such that:

$$\{ua\} \in [\frac{w}{N}, \frac{w+1}{N}) \quad \text{and} \quad \{va\} \in [\frac{w}{N}, \frac{w+1}{N}).$$

Let $q = |u - v|$. Then for some $p \in \mathbb{Z}$, we obtain $|qa - p| < \frac{1}{N}$. Dividing by q we get

$$|a - \frac{p}{q}| < \frac{1}{Nq} \leq \frac{1}{q^2} \quad \text{as } 0 < q \leq N.$$

So, we have found one. We now show that the number of such pairs (p, q) is infinite.

On the contrary, assume that there are only a finite number of rational numbers

$$r_i = \frac{p_i}{q_i}, \quad \text{for } i = 1, \dots, M, \quad \text{with } |a - r_i| < \frac{1}{q_i^2}.$$

Since a is an irrational number, none of the differences, $|a - r_i|$ for $i = 1, 2, \dots, M$, will be exactly 0. Therefore, there exists an integer Q such that

$$|a - r_i| > \frac{1}{Q} \quad \text{for all } i = 1, \dots, M.$$

We now, apply our earlier argument to this Q to get a rational number

$$r = \frac{p}{q} \quad \text{such that } |a - r| < \frac{1}{Qq} \leq \frac{1}{Q}.$$

Hence r can't be one of the r_i , for $i = 1, \dots, M$. On the other hand, we also have, $|a - r| < \frac{1}{q^2}$ contradicting the assumption that the fractions r_i , for $i = 1, \dots, M$, were all the fractions with this property. \square

The readers should look at the proof more clearly and find out for themselves, the line where the irrationality of a was used?

2. Given any sequence of distinct $mn + 1$ real numbers, some subsequence of $(m + 1)$ numbers is strictly increasing or some subsequence of $(n + 1)$ numbers is strictly decreasing.

Before we give the proof of the statement, check that the statement fails if we have exactly mn numbers. For example, consider the sequence 4, 3, 2, 1, 8, 7, 6, 5, 12, 11, 10, 9 of $12 = 3 \times 4$ distinct numbers. This sequence neither has an increasing subsequence of 4 numbers nor a decreasing subsequence of 5 numbers.

PROOF. Let $T = \{a_j : j = 1, 2, \dots, nm + 1\}$ be the given sequence and consider the set $S = \{\ell_1, \ell_2, \dots, \ell_{nm+1}\}$, where ℓ_i is the length of the largest increasing subsequence of T starting with a_i .

If one of the $\ell_i \geq m + 1$, then we have obtained an increasing subsequence of length $m + 1$. If each $\ell_i \leq m$, then we have $mn + 1$ numbers ℓ_i 's and each of them lies between 1 and m . Hence there are at least $n + 1$, ℓ_i 's which take the same value. So, suppose that

$$\ell_{i_1} = \ell_{i_2} = \dots = \ell_{i_{n+1}}. \quad (2.2.1)$$

We claim that $a_{i_1} > a_{i_2} > \dots > a_{i_{n+1}}$.

We will show that $a_{i_1} > a_{i_2}$. The same argument will give the other inequalities. On the contrary, let if possible $a_{i_1} < a_{i_2}$ (equality is not allowed as the numbers are distinct). Then consider the largest increasing subsequence $\{\alpha_i\}_{i=1}^{\ell_{i_2}}$ of T that has length ℓ_{i_2} . Then $\alpha_1 = a_{i_2}$ and we have an increasing subsequence

$$a_{i_1} < a_{i_2} = \alpha_1 < \alpha_2 < \dots < \alpha_{\ell_{i_2}}$$

of T of length $\ell_{i_2} + 1$. So, by definition and Eq. (2.2.1), $\ell_{i_1} \geq \ell_{i_2} + 1 = \ell_{i_1} + 1$. A contradiction. Hence the proof of the problem is complete. \square

3. Consider a chess board with two of the diagonally opposite corners removed. Is it possible to cover the board with pieces of domino whose size is exactly two board squares?

Solution: No, it is not possible. The reason being: Two diagonally opposite squares on a chess board are of the same color. So, the removal leads to a situation where the number of squares of one color exceeds by 2 the number of squares of another color. However, every placement of domino pieces establishes an one to one and onto function between the set of white squares and the set of black squares. If the two sets have different number of elements, then, by the Pigeonhole Principle, we cannot have a one to one and onto function between the two sets.

4. Prove that however one selects 55 integers $1 \leq x_1 < x_2 < x_3 < \dots < x_{55} \leq 100$, there will be some two that differ by 9, some two that differ by 10, a pair that differ by 12, and a

pair that differ by 13. Surprisingly, there need not be a pair of numbers that differ by 11.
Hint: Given a run of $2n$ consecutive integers: $a + 1, a + 2, \dots, a + 2n - 1, a + 2n$, there are n pairs of numbers that differ by n : $(a + 1, a + n + 1), (a + 2, a + n + 2), \dots, (a + n, a + 2n)$. Therefore, by the Pigeonhole Principle, if one selects more than n numbers from the set, two are liable to belong to the same pair that differ by n .

- Exercise 2.2.3**
1. Prove that if n is odd then for any permutation p of the set $\{1, 2, \dots, n\}$ the product $P(p) = (1 - p(1))(2 - p(2)) \dots (n - p(n))$ is necessarily even.
 2. At a party of n people, some pair of people are friends with the same number of people at the party. We assume that each person is friendly to at least one person at the party.
 3. Prove that among any five points selected inside an equilateral triangle with side equal to 1, there always exists a pair at the distance not greater than $.5$.
 4. Five points are chosen at the nodes of a square lattice (grid). Why is it certain that at least one mid-point of a line joining a pair of chosen points, is also a lattice point?
 5. Suppose $f(x)$ is a polynomial with integral coefficients. If $f(x) = 4$ for three distinct integers a, b , and c , prove that, for no integer, $f(x)$ can be equal to 5.
 6. Prove that there exist two powers of 3 whose difference is divisible by 2005.
 7. Prove that there exists a power of three that ends with 0001.
 8. Does there exist a multiple of 2007 that has all its digits 2? Explain your answer.
 9. If 9 people are seated in a row of 12 chairs, then some consecutive set of 3 chairs are filled with people.
 10. Given any sequence of n integers, positive or negative, not necessarily all different, some consecutive subsequence has the property that the sum of the members of the subsequence is a multiple of n .
 11. Given any 1004 integers, some two of them differ by, or sum to, a multiple of 2005.
 12. Mr. Fastfood takes at least one pizza a day for 15 days. If he takes 25 pizzas altogether, show that in some sequence of consecutive days he takes exactly 4 pizzas.
 13. During the year 2005, a book store, which was open 7 days a week, sold at least one book each day, and a total of 600 books over the entire year. Show that there must have been a period of consecutive days when exactly 129 books were sold.

14. Given any 6 integers from 1 to 10, some two of them have an odd sum.
15. Suppose you are given a set A of nine different integers from the set $T = \{1, 2, \dots, 65\}$. Prove that you can always find two disjoint non-empty subsets, S and T of A , such that the sum of elements in S equals the sum of elements in T .
16. Suppose one is given a set $A = \{x_1, x_2, \dots, x_6\}$ consisting of 6 distinct integers from the set $\{1, 2, \dots, 13\}$. Does there exist two distinct disjoint subsets B and C of A such that their elements sum to the same number?
17. Show that if we select a subset of $n + 1$ numbers from the set $\{1, 2, \dots, 2n\}$ then some pair of numbers in the subset are relatively prime.
18. Show that the pigeonhole principle is the same as saying that at least one of the numbers a_1, a_2, \dots, a_n is greater than or equal to their average $\frac{a_1 + a_2 + \dots + a_n}{n}$.
19. Consider two discs A and B , each having $2n$ equal sectors. Suppose each sector is painted either yellow or green. On disc A exactly n sectors are coloured yellow and exactly n are coloured green. For disc B there are no constraints. Show that there is a way of putting the two discs, one above the other, so that at least n corresponding regions have the same colours.
20. Let n be an odd positive number. Show that there exists $\ell \in \mathbb{N}$ such that n divides $2^\ell - 1$.
21. There are 7 distinct real numbers. Is it possible to select two of them, say x and y such that $0 < \frac{x - y}{1 + xy} < \frac{1}{\sqrt{3}}$?
22. Given any sequence of n integers, positive or negative, not necessarily all different, prove that there exists a consecutive subsequence that has the property that the sum of the members of this subsequence is a multiple of n .
23. Colour the plane with two colours, say yellow and green. Then prove the following:
- there exist two points at a distance of 1 unit which have been coloured with the same colour.
 - there is an equilateral triangle all of whose vertices have the same color.
 - there is a rectangle all of whose vertices have the same color.
24. Show that in any group of six people there are either three mutual friends or three mutual strangers.

25. Let m and n be two coprime integers. Prove that there exists integers x, y such that $mx + ny = 1$.

26. Let m and n be two coprime positive integers. Also, let $a, b \in \mathbb{Z}$. Then prove that the system of congruences

$$x \equiv a \pmod{m} \quad \text{and} \quad x \equiv b \pmod{n}.$$

has a solution.

27. Does there exist a number of the form $777 \cdots 7$ which is a multiple of 2007.

3 Principle of Inclusion and Exclusion

The following result is well known and hence we omit the proof.

Theorem 2.3.1 *Let U be a finite set. Suppose A and B are distinct proper subsets of U . Then the number of elements of U that are neither in A nor in B are*

$$|U| - (|A| + |B| - |A \cap B|).$$

A slight generalisation of this to three distinct proper sets A, B and C is also well known. To get a result that generalises the above theorem for n distinct proper subsets A_1, A_2, \dots, A_n , we need the following notations:

$$S_1 = \sum_{i=1}^n |A_i|, \quad S_2 = \sum_{1 \leq i < j \leq n} |A_i \cap A_j|, \quad S_3 = \sum_{1 \leq i < j < k \leq n} |A_i \cap A_j \cap A_k|, \dots, \quad S_n = |A_1 \cap A_2 \cdots \cap A_n|.$$

With the notations as defined above, we have the following theorem.

Theorem 2.3.2 *Let U be a finite set. Suppose A_1, A_2, \dots, A_n are distinct proper subsets of U . Then the number of elements of U that are in none of A_1, A_2, \dots, A_n is given by*

$$|U| - S_1 + S_2 - S_3 + \cdots + (-1)^n S_n. \quad (2.3.1)$$

PROOF. We show that if an element $x \in U$ belongs to exactly k of the subsets A_1, A_2, \dots, A_n for some $k \geq 1$ then its contribution in (2.3.1) is zero. Suppose x belongs to exactly k subsets $A_{i_1}, A_{i_2}, \dots, A_{i_k}$. Then we observe the following:

1. The contribution of x in $|U|$ is 1.
2. The contribution of x in S_1 is k as $x \in A_{i_j}$, $1 \leq j \leq k$.

3. The contribution of x in S_2 is $\binom{k}{2}$ as $x \in A_{i_j} \cap A_{i_l}$, $1 \leq j < l \leq k$.
4. The contribution of x in S_3 is $\binom{k}{3}$ as $x \in A_{i_j} \cap A_{i_l} \cap A_{i_m}$, $1 \leq j < l < m \leq k$.

Proceeding this way, we have

5. The contribution of x in S_k is $\binom{k}{k} = 1$, and
6. The contribution of x in S_ℓ for $\ell \geq k + 1$ is 0.

So, the contribution of x in (2.3.1) is

$$1 - k + \binom{k}{2} - \binom{k}{3} + \cdots + (-1)^{k-1} \binom{k}{k-1} + (-1)^k \binom{k}{k} + 0 \cdots + 0 = (1-1)^k = 0.$$

□

Example 2.3.3 1. How many 10-letter words do not contain all the vowels?

Solution: Let U be the set consisting of all 10-letters words and let A_α denote the number of 10-letter words that does not contain α . Then we need to compute

$$|A_a \cup A_e \cup A_i \cup A_o \cup A_u| = S_1 - S_2 + S_3 - S_4 + S_5.$$

Note that

$$S_1 = \sum_{\alpha \text{ is a vowel}} |A_\alpha| = \binom{5}{1} 25^{10}, \quad S_2 = \binom{5}{2} 24^{10}, \quad S_3 = \binom{5}{3} 23^{10}, \quad S_4 = \binom{5}{4} 22^{10},$$

and $S_5 = 21^{10}$.

So, the required answer is $\sum_{k=1}^5 (-1)^{k-1} \binom{5}{k} (26-k)^{10}$.

2. How many integers between 1 and 1000 are not divisible by any of 2, 3, 11, 13?

Solution: Let $U = \{1, 2, 3, \dots, 1000\}$ and let $A_i = \{n \in U : i \text{ divides } n\}$ for $i = 2, 3, 11, 13$. Note that we are interested in calculating $|U| - |A_2 \cup A_3 \cup A_{11} \cup A_{13}|$. Observe that

$$\begin{aligned} |A_2| &= \lfloor \frac{1000}{2} \rfloor = 500, & |A_3| &= \lfloor \frac{1000}{3} \rfloor = 333, & |A_{11}| &= \lfloor \frac{1000}{11} \rfloor = 90, & |A_{13}| &= \lfloor \frac{1000}{13} \rfloor = 76, \\ |A_2 \cap A_3| &= \lfloor \frac{1000}{6} \rfloor = 166, & |A_2 \cap A_{11}| &= \lfloor \frac{1000}{22} \rfloor = 45, & |A_2 \cap A_{13}| &= \lfloor \frac{1000}{26} \rfloor = 38, \\ |A_3 \cap A_{11}| &= \lfloor \frac{1000}{33} \rfloor = 30, & |A_3 \cap A_{13}| &= \lfloor \frac{1000}{39} \rfloor = 25, & |A_{11} \cap A_{13}| &= \lfloor \frac{1000}{143} \rfloor = 6, \\ |A_2 \cap A_3 \cap A_{11}| &= 15, & |A_2 \cap A_3 \cap A_{13}| &= 12, & |A_2 \cap A_{11} \cap A_{13}| &= 3, \\ |A_3 \cap A_{11} \cap A_{13}| &= 2, & |A_2 \cap A_3 \cap A_{11} \cap A_{13}| &= 1. \end{aligned}$$

Thus, the required answer is

$$1000 - ((500+333+90+76) - (166+45+38+30+25+6) - (15+12+3+2) - 1) = 1000 - 720 = 280.$$

3. **Euler's ϕ -function Or Euler's totient function** Let n denote a positive integer. Then the Euler ϕ -function is defined by

$$\phi(n) = |\{k : 1 \leq k \leq n, \gcd(n, k) = 1\}|.$$

Determine a formula for $\phi(n)$ in terms of its prime factors.

Solution: Let $n = p_1^{\alpha_1} p_2^{\alpha_2} \cdots p_k^{\alpha_k}$ be the unique decomposition of n as product of distinct primes p_1, p_2, \dots, p_k . Suppose $U = \{1, 2, \dots, n\}$ and $A_{p_i} = \{m \in U : p_i \text{ divides } m\}$ for $1 \leq i \leq k$. So, by definition

$$\begin{aligned} \phi(n) &= n - \sum_{i=1}^k \frac{n}{p_i} + \sum_{1 \leq i < j \leq k} \frac{n}{p_i p_j} - \cdots + (-1)^k \frac{n}{p_1 p_2 \cdots p_k} \\ &= n \prod_{i=1}^k \left(1 - \frac{1}{p_i}\right). \end{aligned}$$

- Exercise 2.3.4**
1. Recall the Derangement problem given on 24 On a rainy day, n students leave their umbrellas (which are indistinguishable) outside their examination room. What is the probability that no student collects the correct umbrella when they finish the examination?
 2. How many ways can 30 red balls be put into 4 distinguishable boxes with at most 10 balls in each box?
 3. How many ways can 30 distinguishable balls be placed into 10 distinguishable boxes with at least 1 box empty?
 4. How many ways can r distinguishable balls be placed into n distinguishable boxes with at least 1 box empty?
 5. Determine the number of onto functions $f : M \rightarrow N$, where $|M| = m$, $|N| = n$ and $n \leq m$ (Recall (1.1.1) for another expression).
 6. How many ways can r distinguishable balls be placed into n distinguishable boxes with no box empty?
 7. How many ways are there to distribute 40 distinguishable books to 25 boys if each boy must get at least one book?
 8. How many ways can the 10 integers $1, 2, 3, \dots, 10$ be arranged with i never immediately followed by $i + 1$?
 9. How many 15-term sequence of digits do not contain all the 10 digits?

10. *In how many ways can n pairs of socks be hung on a line so that adjacent socks are from different pairs, if socks within a pair are indistinguishable and each pair is different.*

Chapter 3

Polya Theory

1 Groups

Our aim in this chapter is to look at groups and use it to the study of questions of the type:

1. How many different necklace configurations are possible if we use 6 beads of 3 different colours? Or for that matter what if we use n beads of m different colours?
2. How many different necklace configurations are possible if we use 12 beads among which 3 are *red*, 5 are *blue* and 4 are *green*? And a generalization of this problem.
3. Counting the number of chemical compounds which can be derived by the substitution of a given set of radicals in a given molecular structure.

It can be easily observed that if we want to look at different configurations of a necklace that are formed with 6 beads of different colours, we need to understand the symmetries of a hexagon. Such a study is achieved through what in literature is called *groups*. Once we have learnt a bit about groups, we study *group action*. This helps us in defining an equivalence relation on the set of colour configurations of the necklace. The equivalence classes so formed give us the distinct colour configurations.

So, the basic object of Polya Theory is to count equivalence classes formed by group action. As a group basically describes the symmetries of a given figure, Polya Theory counts the number of distinct objects under symmetry.

Before coming to the definition and its properties, let us look at the properties of the sets \mathbb{N} , \mathbb{Z} , \mathbb{Q} , \mathbb{R} and \mathbb{C} . We know that the sets \mathbb{Z} , \mathbb{Q} , \mathbb{R} and \mathbb{C} satisfy the following:

1. for every $a, b \in \mathbb{Z} (\mathbb{Q}, \mathbb{R}, \mathbb{C})$, $a + b \in \mathbb{Z} (\mathbb{Q}, \mathbb{R}, \mathbb{C})$;
2. for every $a, b, c \in \mathbb{Z} (\mathbb{Q}, \mathbb{R}, \mathbb{C})$, $(a + b) + c = a + (b + c)$;

3. the element zero, denoted $\mathbf{0}$, is in all the three sets and has the property that for every $a \in \mathbb{Z} (\mathbb{Q}, \mathbb{R}, \mathbb{C})$, $a + \mathbf{0} = a = \mathbf{0} + a$;
4. For every element $a \in \mathbb{Z} (\mathbb{Q}, \mathbb{R}, \mathbb{C})$, there exists an element $-a \in \mathbb{Z} (\mathbb{Q}, \mathbb{R}, \mathbb{C})$ such that $a + (-a) = \mathbf{0} = -a + a$;
5. We also have $a + b = b + a$ for every $a, b \in \mathbb{Z} (\mathbb{Q}, \mathbb{R}, \mathbb{C})$.

Now, let us look at the sets $\mathbb{Z}^* = \mathbb{Z} - \{\mathbf{0}\}$, $\mathbb{Q}^* = \mathbb{Q} - \{\mathbf{0}\}$, $\mathbb{R}^* = \mathbb{R} - \{\mathbf{0}\}$ and $\mathbb{C}^* = \mathbb{C} - \{\mathbf{0}\}$. We know that the following statements to be true for the sets \mathbb{Z}^* , \mathbb{Q}^* , \mathbb{R}^* and \mathbb{C}^* :

- (1') for every $a, b \in \mathbb{Z}^* (\mathbb{Q}^*, \mathbb{R}^*, \mathbb{C}^*)$, $a \cdot b \in \mathbb{Z}^* (\mathbb{Q}^*, \mathbb{R}^*, \mathbb{C}^*)$;
- (2') for every $a, b, c \in \mathbb{Z}^* (\mathbb{Q}^*, \mathbb{R}^*, \mathbb{C}^*)$, $(a \cdot b) \cdot c = a \cdot (b \cdot c)$;
- (3') the element identity, *i.e.*, the unit element $\mathbf{1}$ is in all the sets $\mathbb{Z}^* (\mathbb{Q}^*, \mathbb{R}^*, \mathbb{C}^*)$ and for all $a \in \mathbb{Z}^* (\mathbb{Q}^*, \mathbb{R}^*, \mathbb{C}^*)$, $a \cdot \mathbf{1} = a = \mathbf{1} \cdot a$;
- (5') We also have $a \cdot b = b \cdot a$ for every $a, b \in \mathbb{Z}^* (\mathbb{Q}^*, \mathbb{R}^*, \mathbb{C}^*)$.

But if we look at property 4 above then for any $a \neq 1, -1$, $a \in \mathbb{Z}^*$, there doesnot exists an element $b \in \mathbb{Z}^*$ such that $a \cdot b = 1 = b \cdot a$. Whereas for the sets \mathbb{Q}^* , \mathbb{R}^* and \mathbb{C}^* there always exists b such that $a \cdot b = 1 = b \cdot a$.

Based on the above examples, an abstract notion called *groups* is defined. We start with a non-empty set G . In G , we define a binary operation $*$. This binary operation can be either addition or multiplication or composition or With this binary operation the elemetns of the set G satisfy few of the following:

1. for every $a, b \in G$, $a * b \in G$ (*Closure Property*);
2. for every $a, b, c \in G$, $(a * b) * c = a * (b * c)$ (*Associativity Property*);
3. there is an element $\mathbf{e} \in G$ such that $a * \mathbf{e} = a = \mathbf{e} * a$ for all $a \in G$ (*Existence of Identity*);
4. For every element $a \in G$, there exists an element $b \in G$ such that $a * b = \mathbf{e} = b * a$ (*Existence of Inverse*);
(if the binary operation is addition, we write $b = -a$, and if the binary operation is multiplication, we write $b = a^{-1}$)
5. For every $a, b \in G$, $a * b = b * a$ (*Commutative Property*).

Thus, we make the following definition.

Definition 3.1.1 (Group) A group G is a non-empty set together with a binary operation, say $*$, satisfying the **first four** conditions mentioned above. We will generally denote a group by $(G, *)$.

In addition, if the set G satisfies the fifth condition, then G is said to be an abelian (commutative) group.

We now look at examples which are important in the study of groups.

Example 3.1.2 1. **The Symmetric group on n letters:** Let N denote the set $\{1, 2, \dots, n\}$.

A function $\sigma : N \rightarrow N$ is called a permutation on n elements if σ is both one to one and onto. The set of all functions $\sigma : N \rightarrow N$ that are both one to one and onto will be denoted by \mathcal{S}_n . That is, \mathcal{S}_n is the set of all permutations of the set $\{1, 2, \dots, n\}$. Then we have the following:

- (a) Suppose $f, g \in \mathcal{S}_n$. Then f and g are two one-to-one and onto functions from the set N to itself. So, the composite function $f \circ g : N \rightarrow N$ is also one-to-one and onto. Hence, $f \circ g \in \mathcal{S}_n$.
- (b) The composition of functions is associative and thus $(f \circ g) \circ h = f \circ (g \circ h)$.
- (c) The function $\mathbf{e} : N \rightarrow N$ defined by $\mathbf{e}(i) = i$ for $i = 1, 2, \dots, n$ is the identity function. That is, check that $f \circ \mathbf{e} = f = \mathbf{e} \circ f$.
- (d) Suppose $f \in \mathcal{S}_n$. As $f : N \rightarrow N$ is a one-to-one and onto function, the function $f^{-1} : N \rightarrow N$ defined by $f^{-1}(i) = j$ whenever $f(j) = i$ for $i = 1, 2, \dots, n$ exists and is also one-to-one and onto. That is, $f \circ f^{-1} = \mathbf{e} = f^{-1} \circ f$ for any $f \in \mathcal{S}_n$.

Thus (\mathcal{S}_n, \circ) is a group. This group is called the Symmetric group on n letters. In general, we represent a permutation σ by $\sigma = \begin{pmatrix} 1 & 2 & \cdots & n \\ \sigma(1) & \sigma(2) & \cdots & \sigma(n) \end{pmatrix}$. This representation of a permutation is called a TWO ROW NOTATION for σ . Observe that as σ is one-to-one and onto function from $\{1, 2, \dots, n\}$ to itself, the numbers $\sigma(1), \sigma(2), \dots, \sigma(n)$ are all distinct. So, there are n choices for $\sigma(1)$, $n - 1$ choices for $\sigma(2)$ (all numbers except $\sigma(1)$ from $\{1, 2, \dots, n\}$), and so on. Hence, the total number of elements in \mathcal{S}_n is $n! = n(n-1) \cdots 2 \cdot 1$.

- 2. (a) Consider a unit square placed at the coordinates $(0, 0, 0)$, $(1, 0, 0)$, $(0, 1, 0)$ and $(1, 1, 0)$. Our aim is to move the square in space and put it back at the initial place. The question arises, what are the possible ways can this be done? The possible configurations are given in Figure 1.1.

Let r denote the counter-clockwise rotation of the square by 90° and f denote the flipping of the square along the vertical axis passing through the midpoint of opposite

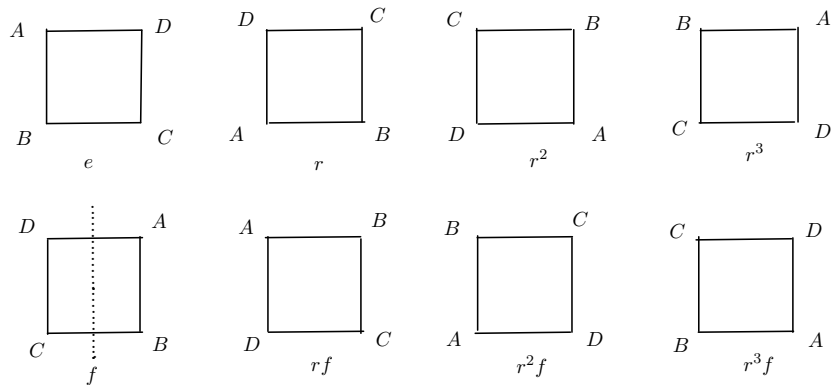

Figure 3.1: Symmetries of a Square.

horizontal edges. Then note that the possible configurations correspond to the set

$$G = \{e, r, r^2, r^3, f, rf, r^2f, r^3f\} \text{ with relations } r^4 = e = f^2 \text{ and } r^3f = fr. \quad (3.1.1)$$

Using (3.1.1), observe that $(rf)^2 = (rf)(rf) = r(fr)f = r(r^3f)f = r^4f^2 = e$. Similarly, it can be checked that $(r^2f)^2 = (r^3f)^2 = e$. That is, all the terms f, rf, r^2f and r^3f are flips.

The group G is generally denoted by D_4 and is called the **Dihedral group** or the **symmetries of a square**. This group can also be represented as follows:

$$\{e, (ABCD), (AC)(BD), (ADCB), (AD)(BC), (BD), (AB)(CD), (AC)\}.$$

Exercise: Relate the two representations of the group D_4 . Use this relationship to calculate the product rule in the new representation.

- (b) In the same way, we can define the symmetries of an equilateral triangle (see Figure 3.2). This group is denoted by D_3 and is represented as

$$D_3 = \{e, r, r^2, f, rf, r^2f\} \text{ with relations } r^3 = e = f^2 \text{ and } r^2f = fr, \quad (3.1.2)$$

where r is a counter-clockwise rotation by 120° and f is a flip.

- (c) The group of symmetries of a pentagon (see Figure 3.3) are

$$G = \{e, (1, 2, 3, 4, 5), (1, 3, 5, 2, 4), (1, 4, 2, 5, 3), (1, 5, 4, 3, 2), (2, 5)(3, 4), \\ (1, 3)(4, 5), (1, 5)(2, 4), (1, 2)(3, 5), (1, 4)(2, 3)\}.$$

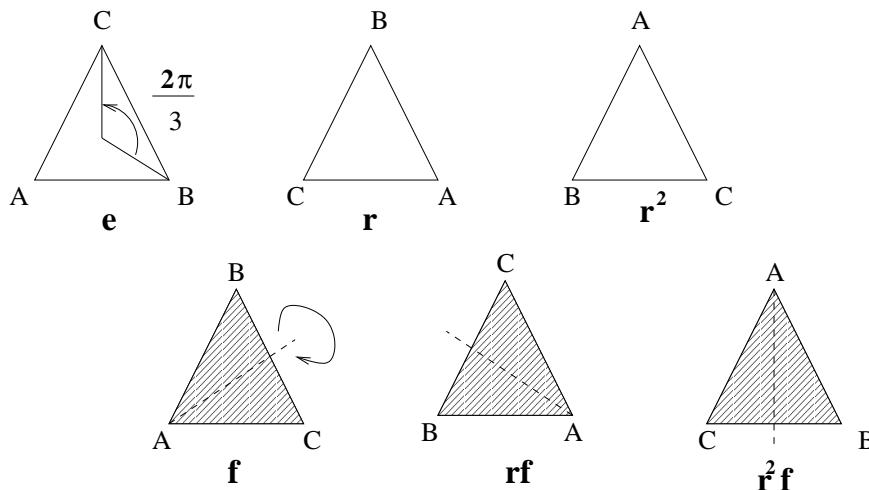

Figure 3.2: Symmetries of an Equilateral Triangle.

(d) In general, we can define symmetries of a regular n -gon. This group is denoted by D_n , has $2n$ elements and is represented as

$$\{e, r, r^2, \dots, r^{n-1}, f, rf, \dots, r^{n-1}f\} \text{ with } r^n = e = f^2 \text{ and } r^{n-1}f = fr. \quad (3.1.3)$$

Here the symbol r stands for a counter-clockwise rotation through an angle of $\frac{2\pi}{n}$ and f stands for a flip.

3. Consider a graph $G = (V, E)$, where V is the vertex set and $E \subseteq V \times V$. When we use the word “graph”, we generally assume that $(i, j) \in E$ whenever $(j, i) \in E$. If this condition doesn't hold, we use the word “directed graph”. For example, for the graph G given in Figure 3.4, the set $V = \{1, 2, 3, 4\}$ and $E = \{(1, 2), (1, 3), (1, 4), (2, 3), (2, 4), (3, 4)\}$. Check that the symmetries of this graph can be represented by the help of the group,

$$\{e, (234), (243), (124), (142), (123), (132), (134), (143), (12)(34), (13)(24), (14)(23)\},$$

where the element (ijk) and respectively $(ij)(kl)$ stand for the one-one onto functions $f = \begin{pmatrix} i & j & k & l \\ j & k & i & l \end{pmatrix}$ and $g = \begin{pmatrix} i & j & k & l \\ j & i & l & k \end{pmatrix}$. For example,

$(124) = \begin{pmatrix} 1 & 2 & 3 & 4 \\ 2 & 4 & 3 & 1 \end{pmatrix}$ and $(13)(24) = \begin{pmatrix} 1 & 2 & 3 & 4 \\ 3 & 4 & 1 & 2 \end{pmatrix}$. Use the product rule that you obtained while studying Example 1 to get the product $(234)(142)$. Does this product equal $(12)(34)$ or $(14)(23)$?

Does this group correspond to the symmetries of a tetrahedron? Give reasons?

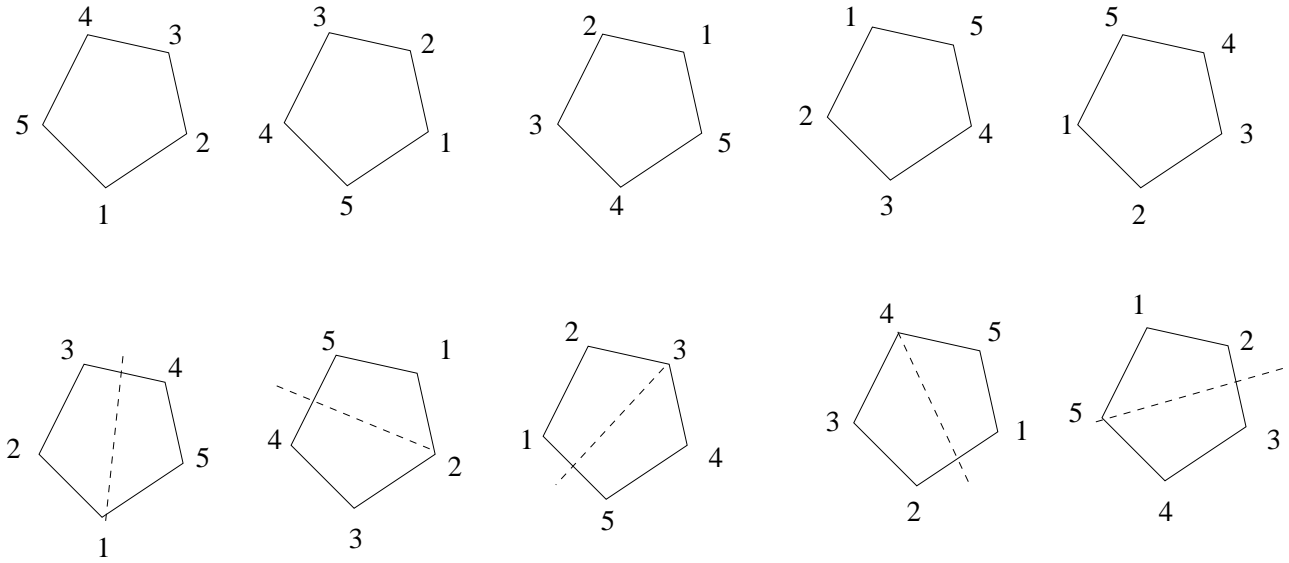

Figure 3.3: Symmetries of a Pentagon.

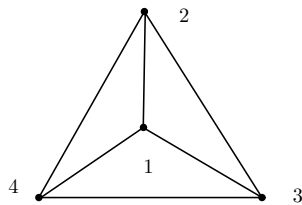

Figure 3.4: A graph on 4 vertices

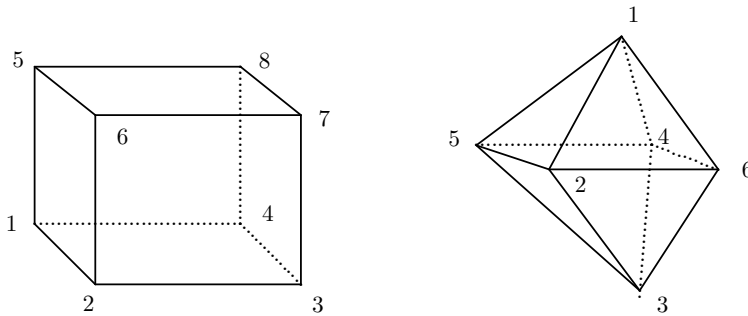

Figure 3.5:

4. Consider the Cube and Octahedron given in Figure 3.5. It can be checked that the group of symmetries of the two figures has 24 elements. We give the group elements for the symmetries of the cube. The readers are supposed to compute the group elements for the symmetries of the octahedron. For the cube (see Figure 3.6), we have

- (a) One element is the identity element e ,
 (b) Nine elements are obtained by rotations that pass through the centre of opposite faces:

$$(1234)(5678), (13)(24)(57)(68), (1432)(5876), (1265)(3784), (16)(25)(38)(47), \\ (1562)(3487), (1485)(2376), (18)(45)(27)(36), (1584)(2673),$$

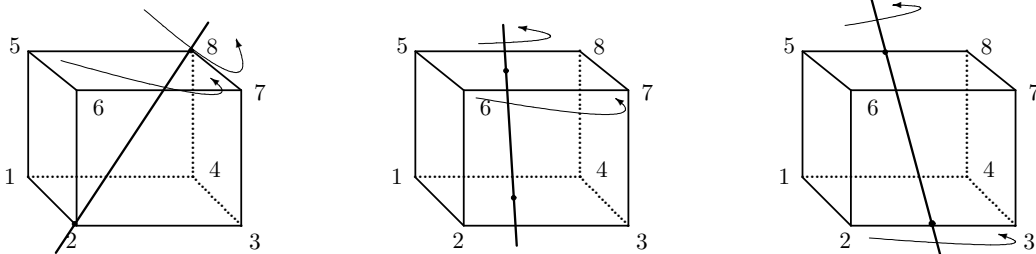

Figure 3.6:

- (c) Eight elements are obtained by rotations that pass through opposite vertices:

$$(254)(368), (245)(386), (163)(457), (136)(475), (275)(138), \\ (257)(183), (168)(274), (186)(247),$$

- (d) Six elements are obtained by rotations that pass through the midpoint of opposite edges:

$$(14)(67)(28)(35), (23)(58)(17)(46), (15)(37)(28)(64), (26)(48)(17)(35), \\ (12)(78)(36)(45), (34)(56)(17)(28).$$

5. Consider the regular solids Icosahedron and Dodecahedron given in Figure 3.7. Note that the Icosahedron has 12 vertices, 20 faces and 30 edges and the Dodecahedron has 20 vertices, 12 faces and 30 edges.

It can be checked that the group of symmetries of the two figures has 60 elements. We give the idea of the group elements for the symmetries of the Icosahedron. The readers are supposed to compute the group elements for the symmetries of the Dodecahedron. For the Icosahedron (see Figure 3.6), we have

- (a) One element is the identity element e ,
 (b) Twenty elements are obtained by rotations that pass through the centre of opposite faces:
 (c) Twenty four elements are obtained by rotations that pass through opposite vertices:

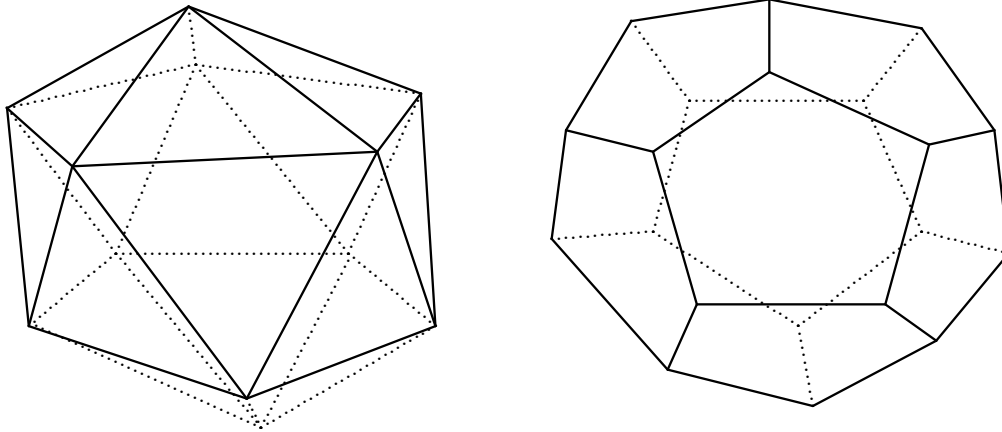

Figure 3.7:

(d) Fifteen elements are obtained by rotations that pass through the midpoint of opposite edges:

Exercise 3.1.3 Determine the group of symmetries of a rectangle and a rhombus?

Theorem 3.1.4 Let G be a group.

1. Then the identity element of G is unique.
2. If $ab = ac$ for some $a, b, c \in G$ then $b = c$ and if $bd = cd$ then $b = c$.
3. For $a \in G$, the inverse of a is unique and is denoted by a^{-1} . Also $(a^{-1})^{-1} = a$.
4. For any $a, b \in G$, $(ab)^{-1} = b^{-1}a^{-1}$.
5. For any positive integer n , and $a \in G$, $(a^n)^{-1} = (a^{-1})^n$.
6. For any $g \in G$, $g^0 = e$.

2 Subgroup

Definition 3.2.1 (Subgroup) Let G be a group with binary operation \star . Let H be a subset of G which also forms a group with respect to the same binary operation \star . Then H is said to be a **subgroup** of G .

Example 3.2.2 1. Let G be a group with identity element e . Then G and $\{e\}$ are themselves groups and hence they are subgroups of G . These two subgroups are called **trivial subgroups**.

2. The set of integers, \mathbb{Z} and the set of rational numbers, \mathbb{Q} are subgroups of the set of real numbers \mathbb{R} , with respect to addition.
3. The set $\{e, r^2, f, r^2f\}$ forms a subgroup of D_4 .
4. The group \mathcal{S}_3 can be thought of as a subgroup of \mathcal{S}_4 . Note that there is one-to-one correspondence between the elements of \mathcal{S}_3 and the set $\{\sigma \in \mathcal{S}_4 : \sigma(4) = 4\}$.

Definition 3.2.3 (Order of a Group) The number of elements in G is denoted by $|G|$ and is called the **order** of G . If $|G| < \infty$, then G is called a group of **finite order**.

Definition 3.2.4 (Order of an Element) Let G be a group and let $g \in G$. Then the **smallest positive integer** m such that $g^m = e$ is called the **order** of g . If no such positive integer exists then g is said to have **infinite order**. The order of an element is denoted by $\mathcal{O}(g)$.

In additive notation, the condition $g^n = e$ stands for $ng = 0$.

Example 3.2.5 1. The only element of order 1 in a group G is the identity element of G .

2. In D_4 , the elements r^2, f, rf, r^2f, r^f have order 2, whereas the elements r and r^3 have order 4.
3. Prove that for any element $a \in G$, $\mathcal{O}(a) = \mathcal{O}(a^{-1})$.

Theorem 3.2.6 (Subgroup Test) Let G be a group and H a subset of G . Then H is a subgroup of G if

1. H is non-empty, and
2. if $a, b \in H$ then ab^{-1} must belong to H . (In additive notation, whenever $a, b \in H$ then $a - b$ must belong to H .)

Proof. As H is non-empty, we can find $x \in H$. Then taking $a = x$ and $b = x$, the second condition gives $e = aa^{-1} \in H$. Now taking $a = e$ and $b = x$, the second condition again gives $x^{-1} = ex^{-1} \in H$ for all $x \in H$.

Also for any two elements $x, y \in H$, we have seen that $x, y^{-1} \in H$ and hence by the second condition again $xy = x(y^{-1})^{-1} \in H$. So, H closed with respect to the binary operation of G . Since the binary operation of H is same as that of G , it is clear that this operation is associative.

■

Example 3.2.7 Let G be an abelian group with identity e . Consider the sets $H = \{x \in G : x^2 = e\}$ and $K = \{x^2 : x \in G\}$. Then both H and K are subgroups of G .

Proof. Clearly $e \in H$ and $e \in K$. Hence, both the sets are non-empty. We will now show that H is a subgroup of G . The proof that K is also a subgroup of G is left as an exercise for the reader.

As H is non-empty, pick $x, y \in H$. Then this assumption implies that $x^2 = e = y^2$. By Theorem 3.2.6, we need to show that $xy^{-1} \in H$. This is equivalent to showing that $(xy^{-1})^2 = e$. As G is abelian,

$$(xy^{-1})^2 = x^2(y^{-1})^2 = e(y^2)^{-1} = e^{-1} = e.$$

Hence, H is indeed a subgroup of G by Theorem 3.2.6.

Theorem 3.2.8 [Two-Step Subgroup Test] Let H be a subset of a group G . Then H is a subgroup of G if

1. H is non-empty,
2. if $a, b \in H$ then ab must belong to H (H is closed with respect to the binary operation of G).
3. if $a \in H$, then $a^{-1} \in H$.

Proof. Left as an exercise. Use the ideas in the proof of Theorem 3.2.6 ■

Theorem 3.2.9 [Finite Subgroup Test] Let H be a non-empty finite subset of a group G . If H is closed with respect to the binary operation of G then H is a subgroup of G .

Proof. By Example 3.2.7.3.2.8, we need to show that for any $a \in H$, $a^{-1} \in H$. If $a = e$ then $a^{-1} = e^{-1} = e$ and we are done. So, assume that $a \neq e$ and $a \in H$. Then the set $S = \{a, a^2, a^3, \dots, a^n, \dots\}$ is a subset of H as H is closed with respect to the binary operation. But H has finite number of elements. Hence all these elements of S are not distinct. That is, there exist positive integers, say m, n , $m > n$ such that $a^m = a^n$. This implies that $a^{m-n} = e$. Hence $a^{-1} = a^{m-n-1}$ and clearly $a^{m-n-1} \in H$. ■

3 Lagrange's Theorem

Definition 3.3.1 Let G be a group and H a subgroup of G . Fix an element $g \in G$ and consider the two sets

$$gH = \{gh : h \in H\}, \text{ and} \tag{3.3.1}$$

$$Hg = \{hg : h \in H\}. \tag{3.3.2}$$

As the identity element $e \in H$, for each $g \in G$, $g \in gH$ and also $g \in Hg$. Therefore, gH is called the left coset of H in G containing g and Hg is called the right coset of H in G containing g .

Example 3.3.2 Consider the group D_4 and let $H = \{e, f\}$ and $K = \{e, r^2\}$ be two subgroups of D_4 . Then observe the following:

$$H = \{e, f\} = Hf, \quad Hr = \{r, fr\} = H(fr),$$

$$H(r^2) = \{r^2, fr^2\} = H(fr^2) \quad \text{and} \quad H(r^3) = \{r^3, fr^3\} = H(fr^3) \quad (3.3.3)$$

$$H = \{e, f\} = fH, \quad rH = \{r, rf\} = (rf)H,$$

$$(r^2)H = \{r^2, r^2f\} = (r^2f)H, \quad \text{and} \quad (r^3)H = \{r^3, r^3f\} = (r^3f)H \quad (3.3.4)$$

$$K = \{e, r^2\} = Kr^2 = r^2K, \quad Kr = \{r, r^3\} = rK = Kr^3 = r^3K,$$

$$Kf = \{f, r^2f\} = fK = k(r^2f) = (r^2f)K, \quad \text{and}$$

$$K(fr) = \{fr, fr^3\} = (fr)K = K(fr^3) = (fr^3)K. \quad (3.3.5)$$

From (3.3.3) and (3.3.4), we note that in general $Hg \neq gH$ for all $g \in D_4$, whereas from (3.3.5), we see that $Kg = gK$ for all $g \in D_4$. So, there should be a way to distinguish between these two subgroups of D_4 . The readers are asked to find another set of groups for which similar statements can be made. Also, check that if M is any subgroup of D_4 with $|M| = 4$ then for all $g \in G$, $gM = Mg$. **The subgroups H of G for which $gH = Hg$ for all $g \in G$ are called Normal Subgroups.**

Theorem 3.3.3 Let H be a subgroup of G . Suppose $a, b \in G$. Then the following results hold for left cosets of H in G :

1. $aH = H$ if and only if $a \in H$,
2. aH is a subgroup of G if and only if $a \in H$,
3. either $aH = bH$ or $aH \cap bH = \emptyset$,
4. $aH = bH$ if and only if $a^{-1}b \in H$.

Aimilar results hold for right cosets of H in G , namely

1. $Ha = H$ if and only if $a \in H$,
2. Ha is a subgroup of G if and only if $a \in H$,
3. either $Ha = Hb$ or $Ha \cap Hb = \emptyset$,
4. $Ha = Hb$ if and only if $ab^{-1} \in H$.

Also, $aH = Ha$ if and only if $H = aHa^{-1} = \{aha^{-1} : h \in H\}$.

We are now ready to prove the main theorem of this section, the Lagrange's Theorem.

Theorem 3.3.4 *Let H be a subgroup of a finite group G . Then $|H|$ divides $|G|$. Moreover, the number of distinct left (right) cosets of H in G equals $\frac{|G|}{|H|}$.*

Proof. Note that the number of left cosets of H in G is finite. Let g_1H, g_2H, \dots, g_mH be the collection of all left cosets of H in G . Then by Theorem 3.3.3, we know that two cosets are either same or they don't have any element in common. Hence, G is a disjoint union of the sets g_1H, g_2H, \dots, g_mH .

Also, it can be easily checked that $|aH| = |bH|$ for all $a, b \in G$. Hence $|g_iH| = |H|$ for all $i = 1, 2, \dots, m$ and

$$|G| = \left| \bigcup_{i=1}^m g_iH \right| = \sum_{i=1}^m |g_iH| = m|H| \quad (\text{the union is disjoint implies the second equality}).$$

Thus, $|H|$ divides $|G|$ and the number of left cosets that equals $m = \frac{|G|}{|H|}$. ■

Remark 3.3.5 *The number m in the Theorem 3.3.4 is called the index of H in G , and is denoted by $[G : H]$ or $i_G(H)$.*

Theorem 3.3.4 is a statement about any subgroup of a finite group. It may so happen that the group G and its subgroup H may have infinite number of elements but the number of left (right) cosets of H in G may be finite. In such cases as well, we talk of index of H in G . For example, consider $H = 10\mathbb{Z}$ as a subgroup of the additive group \mathbb{Z} . Then the index of H in \mathbb{Z} is 10. In general, fix a positive integer m and consider the subgroup $m\mathbb{Z}$ of the additive group \mathbb{Z} . Then it can be easily shown that $[\mathbb{Z} : m\mathbb{Z}] = m$.

Remark 3.3.6 *The converse of Lagrange's Theorem is false. To see this consider the group G discussed in Example 3. This group has 12 elements and 6 divides 12. But G doesn't have a subgroup of order 6.*

Proof. *Let H be a subgroup of order 6 in G , where*

$$G = \{e, (234), (243), (124), (142), (123), (132), (134), (143), (12)(34), (13)(24), (14)(23)\}.$$

Observe that all the elements of G of the form (ijk) have order 3. Hence G has 8 elements of order 3. Let $a \in G$ with $\mathcal{O}(a) = 3$. Consider the cosets H, aH and a^2H (as $a^3 = e$, we don't have any other coset). As $[G : H] = 2$, at most two of the cosets H, aH and a^2H are distinct. But equality of any two of them implies that $a \in H$. This implies that all the 8 elements of order 3 in G must be elements of H . That is, H must have at least 9 elements (8 elements of order 3 and one identity). This is absurd as $|H| = 6$. ■

3.A Applications of Lagrange's Theorem

we now derive some important corollaries of Lagrange's Theorem. We omit the proof as it can be found in any standard textbook on Groups. The first corollary is about the order of an element of a finite group.

Corollary 3.3.7 *Let G be a finite group and let $g \in G$. Then $\mathcal{O}(g)$ divides $|G|$.*

Remark 3.3.8 *The above corollary implies that if G is a finite group of order n then the possible orders of its elements are only the divisors of n . For example, if $|G| = 30$ then for any $g \in G$, $\mathcal{O}(g) \in \{1, 2, 3, 5, 6, 10, 15, 30\}$.*

Let G be a finite group. Then in the first corollary, we have shown that for any $g \in G$, $\mathcal{O}(g)$ divides $|G|$. Therefore, $|G| = m\mathcal{O}(g)$ for some positive integer m . Hence

$$g^{|G|} = g^{m\mathcal{O}(g)} = (g^{\mathcal{O}(g)})^m = e^m = e.$$

This observation gives us the next corollary.

Corollary 3.3.9 *Let G be a finite group. Then $g^{|G|} = e$ for all $g \in G$.*

We use this corollary to prove a famous result called *Fermat's Little Theorem*.

Corollary 3.3.10 *Let a be any positive integer and p be a prime. Then $a^{p-1} \equiv 1 \pmod{p}$ if p does not divide a . In general, $a^p \equiv a \pmod{p}$.*

We now give prove the Euler's Theorem which is a generalisation of Fermat's Little Theorem.

Corollary 3.3.11 *Let $a, n \in \mathbb{Z}$ with $n > 0$. If $\gcd(a, n) = 1$ then $a^{\varphi(n)} \equiv 1 \pmod{n}$.*

Example 3.3.12 1. *Find the unit place in the expansion of 13^{1001} .*

Solution : *Observe that $13 \equiv 3 \pmod{10}$. So, $13^{1001} \equiv 3^{1001} \pmod{10}$. Now note that $3 \in U_{10}$ and $3^{|U_{10}|} = 1 \pmod{10}$. But $|U_{10}| = 4$. Also, $1001 = 4 \cdot 250 + 1$. Hence*

$$13^{1001} \equiv 3^{1001} \equiv 3^{4 \cdot 250 + 1} \equiv (3^4)^{250} \cdot 3^1 \equiv 1 \cdot 3 \equiv 3 \pmod{10}.$$

Hence, the unit place in the expansion of 13^{1001} is 3.

2. *Find the unit and tens place in the expansion of 23^{1002} .*

Solution : *Observe that $23 \in U_{100}$ and $23^{|U_{100}|} = 1 \pmod{100}$. But $|U_{100}| = 40$ and $1002 = 40 \cdot 25 + 2$. Hence*

$$23^{1002} \equiv 23^{40 \cdot 25 + 2} \equiv (23^{40})^{25} \cdot 23^2 \equiv 1 \cdot 23^2 \equiv 529 \equiv 29 \pmod{100}.$$

Hence, the unit place is 9 and the tens place is 2 in the expansion of 23^{1002} .

3. *Compute the last three digits in the expansion of 29^{1201} .*

Try it yourself.

4 Symmetric Groups

We have already seen the Symmetric group \mathcal{S}_n in Example 1. We now want to understand this group in a better fashion. This group is also known as the *Permutation group* as its elements correspond to permutation of the numbers $1, 2, \dots, n$.

We also learnt the two-row notation for any element $\sigma \in \mathcal{S}_n$. There is another notation for permutations that is often very useful. This notation is called the *cycle notation*. Let us try to understand this notation.

Definition 3.4.1 Let $\sigma \in \mathcal{S}_n$ and let $S = \{i_1, i_2, \dots, i_k\} \subseteq \{1, 2, \dots, n\}$ be distinct. If σ satisfies

$$\sigma(i_\ell) = i_{\ell+1} \text{ for } \ell = 1, 2, \dots, k-1, \quad \sigma(i_k) = i_1, \quad \text{and } \sigma(r) = r \text{ for } r \notin S$$

then σ is called a *k-cycle* and is denoted by $\sigma = (i_1, i_2, \dots, i_k)$ or $(i_2, i_3, \dots, i_k, i_1)$ and so on.

Example 3.4.2 1. The permutation $\begin{pmatrix} 1 & 2 & 3 & 4 & 5 \\ 2 & 3 & 4 & 1 & 5 \end{pmatrix}$ in cycle notation can be written as (1234) or (2341) or (3412) or (4123).

2. The permutation $\begin{pmatrix} 1 & 2 & 3 & 4 & 5 & 6 \\ 2 & 3 & 1 & 4 & 6 & 5 \end{pmatrix}$ in cycle notation equals (123)(65).

3. Consider two permutations $\sigma = (143)(27)$ and $\tau = (1357)(246)$. Then, note the following:
 $(\sigma \circ \tau)(1) = \sigma(\tau(1)) = \sigma(3) = 1$, $(\sigma \circ \tau)(2) = \sigma(\tau(2)) = \sigma(4) = 3$, $(\sigma \circ \tau)(3) = \sigma(\tau(3)) = \sigma(5) = 5$, $(\sigma \circ \tau)(4) = \sigma(\tau(4)) = \sigma(6) = 6$, $(\sigma \circ \tau)(5) = 2$, $(\sigma \circ \tau)(6) = 7$ and $(\sigma \circ \tau)(7) = 4$.
Hence

$$\sigma \circ \tau = \begin{pmatrix} 1 & 2 & 3 & 4 & 5 & 6 & 7 \\ 1 & 3 & 5 & 6 & 2 & 7 & 4 \end{pmatrix} = (235)(467).$$

4. Similarly check that $(1456)(152) = (16)(245)$.

Definition 3.4.3 Two cycles $\sigma = (i_1, i_2, \dots, i_t)$ and $\tau = (j_1, j_2, \dots, j_s)$ are said to be disjoint if

$$\{i_1, i_2, \dots, i_t\} \cap \{j_1, j_2, \dots, j_s\} = \emptyset.$$

The proof of the following theorems can be obtained from any standard book on Groups.

Theorem 3.4.4 Let $\sigma \in \mathcal{S}_n$. Then σ can be written as a product of disjoint cycles.

Remark 3.4.5 Observe that the representation of a permutation as a product of disjoint cycles, none of which is the identity, is unique upto the order of the disjoint cycles.

Definition 3.4.6 A permutation $\sigma \in \mathcal{S}_n$, is said to have the cycle structure $z_{\ell_1}^{k_1} z_{\ell_2}^{k_2} \dots z_{\ell_t}^{k_t}$, if σ is a product of k_1 cycles of length ℓ_1 , k_2 cycles of length ℓ_2 and so on till k_t cycles of length ℓ_t , where the z_i 's are indeterminates.

Note that $\sum_{i=1}^t \ell_i k_i = n$.

Example 3.4.7 Let $\sigma = \begin{pmatrix} 1 & 2 & 3 & 4 & 5 & 6 & 7 & 8 & 9 & 10 & 11 & 12 & 13 & 14 & 15 \\ 3 & 6 & 7 & 10 & 14 & 1 & 2 & 13 & 15 & 4 & 11 & 5 & 8 & 12 & 9 \end{pmatrix}$. Then in the cycle notation,

$$\sigma = (1\ 3\ 7\ 2\ 6)\ (4\ 10)\ (5\ 14\ 12)\ (8\ 13)\ (9\ 15)\ (11)$$

and the cycle structure of σ is $z_1 z_2^3 z_3 z_5$.

Exercise 3.4.8 1. Check that the 12 elements that we have obtained in Example 3 correspond to the elements of \mathcal{A}_4 . This is the geometrical interpretation of \mathcal{A}_4 .

2. Compute the group of symmetries of an equilateral triangle. Check that this corresponds to the group \mathcal{S}_3 .

3. Find the group of symmetries of the faces of the left figure and the symmetries of the edges of the right figure given in Figure 3.8

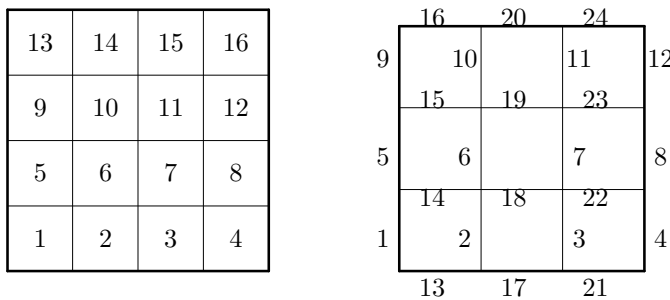
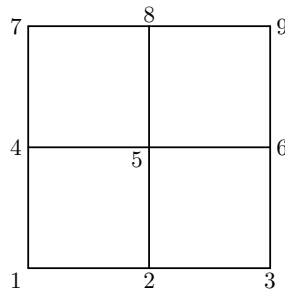

Figure 3.8:

4. Compute the group of symmetries of vertices of a 2×2 square given in Figure 3.9.

Figure 3.9: Symmetries of 2×2 Square.

5 Group Action

Definition 3.5.1 Let (G, \star) be a group with identity e . Then G is supposed to act on a set X if there exists a map, say $f : G \times X \rightarrow X$ such that

1. $f(e, x) = x$ for all $x \in X$, and
2. $f(g, f(h, x)) = f(g \star h, x)$ for all $x \in X$ and $g, h \in G$.

Remark 3.5.2 1. Observe that, we just need to say that $g \cdot x \in X$ for all $g \in G$ and $x \in X$, in place of $f(g, x)$.

2. With this understanding, for a fixed element $g \in G$, the set $\{g \cdot x \mid x \in X\}$ is same as the set X . For if $g \cdot x = g \cdot y$, then we necessarily have

$$x = e \cdot x = (g^{-1} \star g)(x) = g^{-1}(g \cdot x) = g^{-1}(g \cdot y) = (g^{-1} \star g)(y) = e \cdot y = y.$$

That is g just permutes the elements of X .

3. It may happen that for all $x \in X$, $g \cdot x = h \cdot x$ even though $g \neq h$.

Example 3.5.3 1. Let G be the group $D_6 = \{e, r, \dots, r^5, f, rf, \dots, r^5 f\}$ with $r^6 = e, f^2 = e$ and $rf = fr^{-1}$. Then this group acts on the labelling of the vertices by the numbers 1, 2, 3, 4, 5, 6 of a regular hexagon. For an example, see figure 3.10

2. Consider the set of ways of labelling the vertices of a square with two colours, say, Red and Blue (see Figure 3.11). Then the group $D_4 = \{e, r, r^2, r^3, f, rf, r^2 f, r^3 f\}$ with $r^4 = e, f^2 = e$ and $rf = fr^{-1}$ acts on the set X as follows:

(a) $e \cdot x = x$ for all $x \in X$ (by definition).

(b) $r \cdot x_1 = x_1, r \cdot x_2 = x_5, r \cdot x_3 = x_2, \dots, r \cdot x_{16} = x_{16}$.

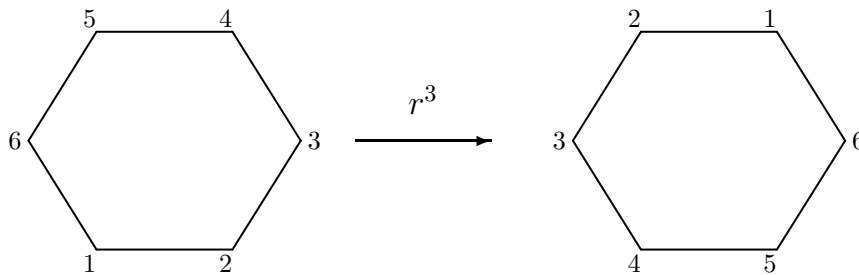

Figure 3.10: Action by r^3 on a labelled hexagon.

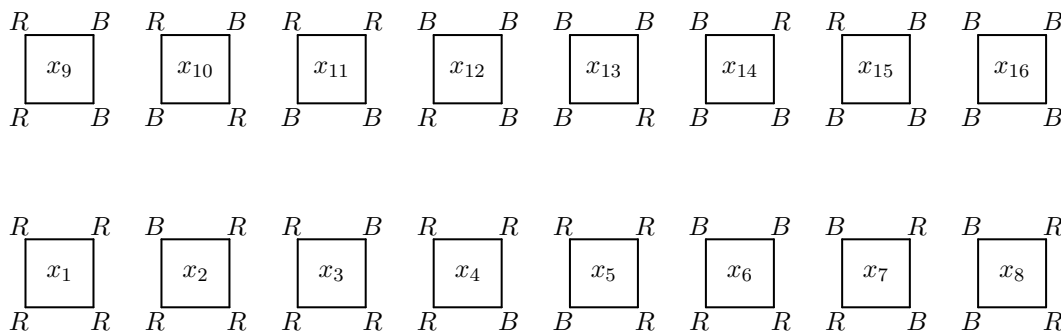

Figure 3.11: Colouring the vertices of a square.

(c) $f \cdot x_1 = x_1, f \cdot x_2 = x_3, f \cdot x_3 = x_2, \dots, f \cdot x_{16} = x_{16}$.

We now define two important sets associated with a group action.

Definition 3.5.4 *Let G act on a set X . Then*

1. *for each fixed $x \in X$, we define $\mathcal{O}(x) = \{g \cdot x : g \in G\} \subset X$, called the Orbit of x under the action of the group G ,*
2. *for each fixed $x \in X$, we define $G_x = \{g \in G : g \cdot x = x\} \subset G$, called the Stabilizer of x in G , and*
3. *for each fixed $g \in G$, we define $F_g = \{x \in X : g \cdot x = x\} \subset X$, called the Fix of g .*

To understand the above definitions, let us consider the following example.

Example 3.5.5 *Consider the set X whose elements consist of ways of labelling the vertices of a square with two colours (see Figure 3.11). Then the group D_4 act on X . In this case, we have*

$$\mathcal{O}(x_2) = \{x_2, x_3, x_4, x_5\}, G_{x_2} = \{e, rf\}, \text{ and } F_{rf} = \{x_1, x_2, x_4, x_7, x_{10}, x_{13}, x_{15}, x_{16}\}.$$

The readers should compute the different sets by taking other examples.

We now state a few results associated with the above definitions. The proofs are omitted as they can be easily verified.

Proposition 3.5.6 *Let G act on a set X .*

1. *Then for each fixed $x \in X$, the set G_x is a subgroup of G .*
2. *Define a relation on the set X by $x \sim y$ if there exists a $g \in G$ such that $g \cdot x = y$. Then this relation defines an equivalence relation on the set X . The equivalence class containing $x \in X$ is given by $\mathcal{O}(x) = \{g \cdot x : g \in G\} \subset X$, the orbit of x under G .*
3. *Fix an $x \in X$. Suppose $t \in \mathcal{O}(x)$. Then $\mathcal{O}(x) = \mathcal{O}(t)$.*

we are now ready to relate the distinct orbits of the set with the cosets of the group.

Theorem 3.5.7 *Let a group (G, \star) act on a set X and fix an element $x \in X$. Then there is a one-to-one correspondence between the elements of $\mathcal{O}(x)$ and the set of all left cosets of G_x in G . In particular,*

$$|\mathcal{O}(x)| = [G : G_x], \text{ the number of left cosets of } G_x \text{ in } G.$$

Moreover, if G is a finite group then $|G| = |\mathcal{O}(x)| \cdot |G_x|$ for all $x \in X$.

Proof. let S be the set of distinct left cosets of G_x in G . Then $S = \{gG_x : g \in G\}$. Consider the map $\tau : S \rightarrow \mathcal{O}(x)$ by

$$\tau(gG_x) = g \cdot x.$$

Let us check that this map is well-defined. So, suppose that the cosets gG_x and hG_x are the same. That is, $gG_x = hG_x$. So, we get the following sequence of assertions:

$$gG_x = hG_x \iff (h^{-1} \star g) \in G_x \iff (h^{-1} \star g)(x) = x \iff h^{-1}(g \cdot x) = x \iff g \cdot x = h \cdot x.$$

These assertions also imply that

$$gG_x = hG_x \iff \tau(gG_x) = \tau(hG_x).$$

Hence, τ is not only well-defined but also one-one. The map τ is onto, because for each $y \in \mathcal{O}(x)$, there exists an $h \in G$ such that $h \cdot x = y$. So, $\tau(hG_x) = h \cdot x = y$ holds. Therefore, we have shown that τ gives a one-to-one correspondence between the elements of $\mathcal{O}(x)$ and the set of all left cosets of G_x in G . This completes the proof of the first part. The other part follows by observing that by definition $[G : G_x] = \frac{|G|}{|G_x|}$ for each subgroup G_x of G whenever $|G|$ is finite. ■

The following lemmas are an immediate consequence of Proposition 3.5.6 and Theorem 3.5.7. We give the proof for the sake of completeness.

Lemma 3.5.8 *Let G be a finite group acting on a set X . Then for each $y \in X$,*

$$\sum_{x \in \mathcal{O}(y)} |G_x| = |G|.$$

Proof. Recall that for each $x \in \mathcal{O}(y)$, $|\mathcal{O}(x)| = |\mathcal{O}(y)|$. Hence, by using $|G| = |G_x| \cdot |\mathcal{O}(x)|$ for all $x \in X$, we get

$$\sum_{x \in \mathcal{O}(y)} |G_x| = \sum_{x \in \mathcal{O}(y)} \frac{|G|}{|\mathcal{O}(x)|} = \sum_{x \in \mathcal{O}(y)} \frac{|G|}{|\mathcal{O}(y)|} = \frac{|G|}{|\mathcal{O}(y)|} \sum_{x \in \mathcal{O}(y)} 1 = |G|.$$

■

Theorem 3.5.9 *Let G be a finite group acting on a set X . Let N denote the number of distinct orbits of X under the action of G . Then*

$$N = \frac{1}{|G|} \sum_{x \in X} |G_x|.$$

Proof. By Lemma 3.5.8, note that $\sum_{x \in \mathcal{O}(y)} |G_x| = |G|$ for all $y \in X$. Let x_1, x_2, \dots, x_N be the representative of the distinct orbits of X under the action of G . Then

$$\sum_{x \in X} |G_x| = \sum_{i=1}^N \sum_{y \in \mathcal{O}(x_i)} |G_{x_i}| = \sum_{i=1}^N |G| = N \cdot |G|.$$

Hence, the result follows. ■

Example 3.5.10 *Let us come back to Example 2. Check that the number of distinct colourings are*

$$\frac{1}{|G|} \sum_{i=1}^{16} |G_{x_i}| = \frac{1}{8} (8 + 2 + 2 + 2 + 2 + 2 + 4 + 2 + 2 + 4 + 2 + 2 + 2 + 2 + 2 + 8) = 6.$$

Remark 3.5.11 *As the above example illustrates, we are able to find the number of distinct configurations using this method. But it is important to observe that this method requires us to list all elements of X . For example, if we colour the vertices of the square with 3 colours, then $|X| = 3^4 = 81$, whereas the number of elements of D_4 (the group that acts as the group of symmetries of a square) remain 8. So, one feels that the calculation may become easy if one has to look at the elements of the group D_4 . Or in general, can we get a formula which relates the number of distinct orbits with the elements of the group, in place of the elements of the set X (as seen above, the group may remain the same but the set X may change and $|X|$ may become very large).*

This query has an affirmative answer and is given as our next result.

Lemma 3.5.12 (Cauchy-Frobenius-Burnside's Lemma) *Let G be a finite group acting on a set X . Let N denote the number of distinct orbits of X under the action of G . Then*

$$N = \frac{1}{|G|} \sum_{g \in G} |F_g|.$$

Proof. Consider the set $S = \{(g, x) \in G \times X : g \cdot x = x\}$. We calculate $|S|$ by two methods. In the first method, let us fix $x \in X$. Then for each fixed $x \in X$, G_x gives the collection of elements of G that satisfy $g \cdot x = x$. So, $|S| = \sum_{x \in X} |G_x|$.

In the second method, let us fix $g \in G$. Then for each fixed $g \in G$, F_g gives the collection of elements of X that satisfy $g \cdot x = x$. So, $|S| = \sum_{g \in G} |F_g|$. That is,

$$\sum_{x \in X} |G_x| = |S| = \sum_{g \in G} |F_g|.$$

Hence, using Theorem 3.5.9, we have

$$N = \frac{1}{|G|} \sum_{g \in G} |F_g|.$$

■

Example 3.5.13 1. *Let us come back to Example 2. We now see that $F_e = 16$, $F_r = 2$, $F_{r^2} = 4$, $F_{r^3} = 2$, $F_f = 4$, $F_{rf} = 8$, $F_{r^2f} = 4$ and $F_{r^3f} = 8$. Hence, the number of distinct configurations are*

$$\frac{1}{|G|} \sum_{g \in G} |F_g| = \frac{1}{8} (16 + 2 + 4 + 2 + 4 + 8 + 4 + 8) = 6.$$

It is important to observe that this calculation can be done just by looking at the cycle structure of the group elements. That is, to calculate the above sum, we need not look at the elements of the set X at all.

2. *Consider the group $C_5 = \{e, r, r^2, r^3, r^4\}$ with $r = (12345)$ and $r^5 = e$. This is a subgroup of D_5 (see Example 2c). Let X be the set of colour patterns obtained by colouring the vertices of the pentagon by three colours Red, Blue and Green (R, B, G). Then note that*

$$F_e = X, F_r = F_{r^2} = F_{r^3} = F_{r^4} = \{RRRRR, BBBB, GGGG\}.$$

So, by Burnside's Lemma, the number of distinct colour patterns upto rotations is

$$\frac{1}{5} (3^5 + 3 + 3 + 3 + 3) = 51.$$

6 The Cycle Index Polynomial

Till now, we haven't cared much about the actual elements of the group G . Polya observed that elements of G with the same *cycle structure* made the same contribution to the sets of *fixed points*. He defined the notion of cycle index polynomial to keep track of the cycle structure of the elements of G .

Definition 3.6.1 *Let G be a permutation group on n symbols. For $g \in G$, let $\ell_k(g)$ denote the number of cycles of g of length k . Then the cycle index polynomial of G , as a permutation group on n symbols, is a polynomial in n variables z_1, z_2, \dots, z_n given by*

$$P_G(z_1, z_2, \dots, z_n) = \frac{1}{|G|} \left(\sum_{g \in G} z_1^{\ell_1(g)} z_2^{\ell_2(g)} \dots z_n^{\ell_n(g)} \right).$$

Example 3.6.2 1. *Let G be the dihedral group D_4 (see Example 2). Then the contributions are as follows:*

$$e = (1)(2)(3)(4) \rightarrow z_1^4, \quad r = (1234) \rightarrow z_4, \quad r^3 = (1432) \rightarrow z_4, \quad r^2 = (13)(24) \rightarrow z_2^2, \\ f = (14)(23) \rightarrow z_2^2, \quad rf = (1)(3)(24) \rightarrow z_1^2 z_2, \quad r^2 f = (12)(34) \rightarrow z_2^2, \quad r^3 f = (13)(2)(4) \rightarrow z_1^2 z_2.$$

Thus,

$$P_G(z_1, z_2, z_3, z_4) = \frac{1}{8} (z_1^4 + 2z_4 + 3z_2^2 + 2z_1^2 z_2).$$

2. *Let G be the dihedral group D_5 (see Example 2c). Then*

$$P_G(z_1, z_2, z_3, z_4, z_5) = \frac{1}{10} (z_1^5 + 4z_5 + 5z_1 z_2^2).$$

3. *It can be checked that the cycle index polynomial of the permutation group induced on the set of vertices, edges and faces obtained by the rotations of the cube are respectively,*

$$P_G(z_1, z_2, \dots, z_8) = \frac{1}{24} (z_1^8 + 6z_4^2 + 9z_2^4 + 8z_1^2 z_3^2) \\ P_G(z_1, z_2, \dots, z_{12}) = \frac{1}{24} (z_1^{12} + 6z_4^3 + 3z_2^6 + 8z_3^4 + 6z_1^2 z_2^5) \\ P_G(z_1, z_2, \dots, z_6) = \frac{1}{24} (z_1^6 + 6z_1^2 z_4 + 3z_1^2 z_2^2 + 6z_2^3 + 8z_3^2)$$

6.A Applications

Let X be a geometrical figure and let Y be the finite set of points of X which is of interest to us. Also, let C be a finite set (say, of colours). Let $\Omega = \{f : f \text{ is a function from } Y \text{ to } C\}$. Observe that an element of Ω gives a colour pattern. Let G be a subgroup of the group of permutations

of the figure X . Then G acts on Ω , the colour patterns of X by the following rule:

Fix an element $x \in Y$. Then for each $\phi \in \Omega$ and $g \in G$, we define

$$(g \star \phi)(x) := g(\phi(x)) = \phi(g^{-1}(x)).$$

Then it can be easily checked that $g \star \phi \in \Omega$ and with the above notations, we have the following theorem.

Theorem 3.6.3 *Let C, X, Y and Ω be as defined above. Also, let G be a subgroup of the group of permutations of the figure X acting on the elements of Ω . Then the number of distinct colour patterns (distinct elements of Ω) is given by*

$$P_G(|C|, |C|, \dots, |C|).$$

Proof. Let $|Y| = n$. Then observe that G is a subgroup of \mathcal{S}_n . So, each $g \in G$ can be written as a product of disjoint cycles. Also, by Burnside's Lemma 3.5.12, the number of distinct colour patterns (distinct orbits under the action of G) is $\frac{1}{|G|} \sum_{g \in G} |F_g|$, where

$$F_g = \{ \phi \in \omega : g(\phi(x)) = \phi(x) \text{ for all } x \in Y \} = \{ \phi \in \omega : g(\phi) = \phi \}.$$

We claim that $g \in G$ fixes a colour pattern (or an element of Ω) if and only if ϕ colours the elements in a given cycle of g with the same colour.

Suppose that $g \star \phi = \phi$. That is, $g(\phi(x)) = \phi(x)$ for all $x \in X$. So, by definition of the action on the colour patterns, we have

$$\phi(g^{-1}(x)) = \phi(x) \text{ for all } x \in X.$$

In particular, for a fixed $y \in X$, we get

$$\phi(y) = \phi(g(y)) = \phi(g^2(y)) = \dots$$

Note that for each fixed $y \in X$, the permutation $(y, g(y), g^2(y), \dots)$ gives a cycle of g . Therefore, if g fixes a colour pattern ϕ , then ϕ assigns the same colour to each element of any cycle of g .

Conversely, if ϕ is such that every point in a given cycle of g is coloured with the same colour, then x and $g^{-1}(x)$ have the same colour for each $x \in X$. That is, $\phi(x) = \phi(g^{-1}(x))$ for all $x \in X$. Or equivalently, $g \star \phi = \phi$. Hence g fixes the colour pattern ϕ . Thus the proof of the claim is complete.

Hence, $|F_g| = |C|^{\ell_1(g)} \cdot |C|^{\ell_2(g)} \dots |C|^{\ell_n(g)}$, where for each k , $1 \leq k \leq n$, $\ell_k(g)$ denotes the number of cycles of g of length k . ■

Example 3.6.4 1. Suppose we are interested in finding our the number of distinct colour patterns, when a pentagon is coloured with 3 colours. Then the group D_5 acts on the colour patterns and the cycle index polynomial of D_5 is $P_G(z_1, z_2, \dots, z_5) = \frac{1}{|D_5|}(z_1^5 + 4z_5 + 5z_1z_2^2)$. Thus by Theorem 3.6.3, the number of distinct patterns is

$$\frac{1}{10}(3^5 + 4 \cdot 3 + 5 \cdot 3 \cdot 3^2) = 39.$$

2. Suppose we have a necklace consisting of 6 beads and we are allowed to chose the beads from three different colours. Then to get the number of distinct necklaces, we note that the group D_6 acts on the colour patterns and the cycle index polynomial of D_6 is $P_G(z_1, z_2, \dots, z_6) = \frac{1}{|D_6|}(z_1^6 + 2z_6 + 2z_3^2 + z_2^3 + 3z_2z_3 + 3z_1^2z_2^2)$. Thus by Theorem 3.6.3, the number of distinct patterns is

$$\frac{1}{12}(3^6 + 2 \cdot 3 + 2 \cdot 3^2 + 4 \cdot 3^3 + 3 \cdot 3^2 \cdot 3^2) = 92.$$

6.B Polya's Inventory Polynomial

In this section, we generalise the above ideas so that we can count the number of necklaces having n beads with the restriction that the number of beads of of each colour may be strictly less than n . To do this, with each element of C , we assign a *weight* to each colour pattern. This weight may be a number, a variable or in general, an element of a commutative ring with identity. So, we again have the same setup. That is, we still have a subgroup G of a group of permutations of a finite set Y , a finite set C of colours and the set Ω consisting of colour patterns. To start with, we have the following definitions.

Definition 3.6.5 Let A be a commutative ring with identity (the elements of A are called weights). Let $w : C \rightarrow A$ be a map that assigns weights to each colour. Then the weight of a colour pattern $\phi : X \rightarrow C$, with respect to the weight function w is given by $w(\phi) = \prod_{x \in X} w(\phi(x))$.

Fix $g \in G$. Then we have seen that g fixes a colour pattern $\phi \in \Omega$ if and only if ϕ colours the elements in a given cycle of g with the same colour. Hence, the weight of each element in a particular cycle is the same. Therefore, all the colour patterns which belong to one and the same orbit, under the action of G , have the same weight, we may define the weight of the pattern as this common value. Thus, we have the following definition.

Definition 3.6.6 Suppose $\Delta \subset \Omega$ is an orbit under the action of a group G . Then the weight of Δ , denoted $w(\Delta)$, is defined to be equal to $w(\phi)$ for any $\phi \in \Delta$.

Example 3.6.7 Let X consist of the set of all six faces of a cube and let G be the group of symmetries of the cube produced by rotations. Let C consist of two colours 'Red' and 'Blue'. We assign the weight R to the Red colour and B to the Blue colour. Then we have the following:

1. if all faces are coloured Blue, the corresponding weight is B^6 ,
2. if two opposite faces are coloured Red and the other four faces are coloured Blue, then the corresponding weight is R^2B^4 ,
3. if two adjacent faces are coloured Red and the other four faces are coloured Blue, then the corresponding weight is R^2B^4 ,
4. if three faces meeting at a vertex are coloured Red and the other three faces meeting at the opposite vertex are coloured Blue, then the corresponding weight is R^3B^3 ,
5. if three arbitrary faces are coloured Red and the other three faces are coloured Blue, then the corresponding weight is R^3B^3 .

The above examples indicate that *different colour patterns need not have different weights*.

We also define the following.

Definition 3.6.8 *The pattern inventory, I under the action of the group G on the colour patterns, Ω , with respect to the weight function w , is the sum of the weights of the orbits. That is, $I = \sum_{\Delta} w(\Delta)$, where the sum runs over all distinct orbits Δ obtained by the action of G on Ω .*

With the above definitions, we are ready to prove the Polya's Enumeration Theorem. To do so, we first need to prove the weighted Burnside's Lemma. This Lemma is the weighted version of the Burnside's Lemma 3.5.12.

Lemma 3.6.9 *With the definition and notations as above,*

$$I = \sum_{\Delta} w(\Delta) = \frac{1}{|G|} \sum_{g \in G} \sum_{\substack{\phi \in \Omega \\ g(\phi) = \phi}} w(\phi)$$

where the summation runs over distinct orbits under the action of G .

Proof. As G acts on Ω , for each $\alpha \in \Omega$, by Lemma 3.5.7 $|G_{\alpha}| \cdot |\mathcal{O}(\alpha)| = |G|$. So, for each $\phi \in \Delta$, $|G_{\phi}| \cdot |\Delta| = |G|$. As $w(\Delta) = w(\phi)$ for all $\phi \in \Delta$, we have

$$w(\Delta) = w(\phi) = \frac{1}{|\Delta|} \sum_{\phi \in \Delta} w(\phi) = \sum_{\phi \in \Delta} \frac{|G_{\phi}|}{|G|} w(\phi) = \frac{1}{|G|} \sum_{\phi \in \Delta} |G_{\phi}| \cdot w(\phi).$$

Thus, using the fact that $\sum_{\phi \in \Omega} w(\phi) = \sum_{\phi \in \Omega} \sum_{\substack{g \in G \\ g(\phi) = \phi}} w(\phi) = \sum_{g \in G} \sum_{\substack{\phi \in \Omega \\ g(\phi) = \phi}} w(\phi)$, we get

$$\begin{aligned} I &= \sum_{\Delta} w(\Delta) = \sum_{\Delta} \frac{1}{|G|} \sum_{\phi \in \Delta} |G_{\phi}| \cdot w(\phi) \\ &= \frac{1}{|G|} \sum_{\Delta} \sum_{\phi \in \Delta} |G_{\phi}| \cdot w(\phi) = \frac{1}{|G|} \sum_{\phi \in \Omega} |G_{\phi}| \cdot w(\phi) \\ &= \frac{1}{|G|} \sum_{\phi \in \Omega} \sum_{\substack{g \in G \\ g(\phi) = \phi}} w(\phi) = \frac{1}{|G|} \sum_{g \in G} \sum_{\substack{\phi \in \Omega \\ g(\phi) = \phi}} w(\phi). \end{aligned}$$

■

We are now in a position to prove the Polya's Enumeration Theorem.

Theorem 3.6.10 (Polya's Enumeration Theorem) *With the definition and notations as above,*

$$I = \sum_{\Delta} w(\Delta) = P_G(x_1, x_2, \dots, x_n),$$

where the summation runs over distinct orbits under the action of G and $x_i = \sum_{c \in C} w(c)^i$, is the i^{th} power sum of the weights of the colours.

Proof. From the weighted Burnside Lemma 3.6.9, we need to prove that

$$\sum_{g \in G} \sum_{\substack{\phi \in \Omega \\ g(\phi) = \phi}} w(\phi) = \sum_{g \in G} \sum_{\phi \in F_g} w(\phi) = \sum_{g \in G} x_1^{\ell_1(g)} x_2^{\ell_2(g)} \dots x_n^{\ell_n(g)},$$

where $\ell_i(g)$ is the number of cycles g whose length equals i . It was shown (see the first paragraph in the proof of Theorem 3.6.3) that F_g consists precisely of those colour schemes which colour each cycle of g with just one colour. Now, we determine the weight of such a colour pattern. To do so, suppose a fixed element $g \in G$ consists of t cycles. Note that for $1 \leq i \leq t$, if X_i denotes the set that contains the numbers in the i^{th} cycle of g , then X_1, X_2, \dots, X_t defines a partition of X . So, for any $\phi \in F_g$, observe that $w(\phi(x)) = w(\phi(g(x)))$, as x and $g(x)$ belong to the same cycle of g . Thus,

$$w(\phi) = \prod_{x \in X} w(\phi(x)) = \prod_{i=1}^t \prod_{x \in X_i} w(\phi(x)) = \prod_{i=1}^t w(\phi(s_i))^{|X_i|}$$

where $s_i \in X_i$. Hence, using the fact that each $g \in G$ has $\ell_k(g)$ cycles of length k , $1 \leq k \leq n$, we have

$$\begin{aligned} \sum_{\phi \in F_g} w(\phi) &= \sum_{\substack{c_1, c_2, \dots, c_t \\ c_i \in C}} \prod_{i=1}^t w(c_i)^{|X_i|} \\ &= \left(\sum_{c \in C} w(c)^{|X_1|} \right) \left(\sum_{c \in C} w(c)^{|X_2|} \right) \cdots \left(\sum_{c \in C} w(c)^{|X_t|} \right) \\ &= \prod_{k=1}^n \left(\sum_{c \in C} w(c)^k \right)^{\ell_k(g)} = \prod_{k=1}^n x_k^{\ell_k(g)}. \end{aligned}$$

Thus we have obtained the required result. ■

Example 3.6.11 1. Consider a necklace consisting of 6 beads that needs to be coloured with 3 colours, say R, B and G . Determine the number of necklaces that have at least one R bead? How many of the necklaces have three R , two B and one G bead?

Solution: Recall that the cycle index polynomial of D_6 (the group that acts on a hexagon) is

$$P(z_1, z_2, \dots, z_6) = \frac{1}{12}(z_1^6 + 4z_2^3 + 2z_3^2 + 2z_6 + 3z_1^2z_2^2).$$

So, for the first part, we are looking at unlimited supply of B and G but at least one R . So, we define the weight of the colour R as x and that of B and G as 1. Thus, by Polya's Enumeration Theorem 3.6.10,

$$\begin{aligned} I &= \frac{1}{12} ((x+1+1)^6 + 4(x^2+1+1)^3 + 2(x^3+1+1)^2 \\ &\quad + 2(x^6+1+1) + 3(x+1+1)^2(x^2+1+1)^2) \\ &= x^6 + 2x^5 + 9x^4 + 16x^3 + 29x^2 + 20x + 15. \end{aligned}$$

So, the required answer is $1 + 2 + 9 + 16 + 29 + 20 = 77$.

For the second part, we define the weights as R, B and G itself. So, we need to find the coefficient of R^3B^2G in

$$\begin{aligned} I &= \frac{1}{12} ((R+B+G)^6 + 4(R^2+B^2+G^2)^3 + 2(R^3+B^3+G^3)^2 \\ &\quad + 2(R^6+B^6+G^6) + 3(R+B+G)^2(R^2+B^2+G^2)^2). \end{aligned}$$

So, the required answer is

$$\frac{1}{12} \left(\binom{6}{3, 2, 1} + 3 \cdot 2 \cdot 2 \right) = \frac{1}{12} \left(\frac{6!}{3!2!} + 6 \right) = 6.$$

We end this chapter with a few Exercises. But before doing so, we give the following example with which Polya started his classic paper on this subject.

Example 3.6.12 *Suppose we are given 6 similar spheres in three different colours, say, three Red, two Blue and one Yellow (spheres of the same colour being indistinguishable). In how many ways can we distribute the six spheres on the 6 vertices of an octahedron freely movable in space?*

Solution: *Here $X = \{1, 2, 3, 4, 5, 6\}$ and $C = \{R, B, Y\}$. Use Example 4 on Page 44 to obtain the cycle structure of the symmetric group of the octahedron acting on the vertices. Hence or otherwise show that the cycle index polynomial is given by*

$$\frac{1}{24} (z_1^6 + 6z_1^2z_4 + 3z_1^2z_2^2 + 8z_3^2 + 6z_2^3).$$

Hence, the number of patterns of the required type is the coefficient of the term R^3B^2Y in

$$I = \frac{1}{24} ((R + B + Y)^6 + 6(R + B + Y)^2(R^4 + B^4 + Y^4) + 3(R + B + Y)^2(R^2 + B^2 + Y^2)^2 + 8(R^3 + B^3 + Y^3)^2 + 6(R^2 + B^2 + Y^2)^3).$$

Check that the coefficient is 3.

- Exercise 3.6.13**
1. *Three black and three white beads are strung together to form a necklace, which can be rotated and turned over. Assuming that the beads of the same colour are indistinguishable, how many different necklace patterns can be made?*
 2. *Suppose we are colouring the edges of a regular tetrahedron with two colours white and black. Then determine the number of patterns that have exactly four black edges and two white edges.*
 3. *The molecules of methane CH_4 consists of a Carbon atom at the center of a regular tetrahedron (see Figure 3.4), bonded to each of four Hydrogen atoms at the vertices. Suppose each Hydrogen atom can either be replaced by an atom of Flourine, Chlorine or Bromine. Then how many essentially different compounds can be produced?*
 4. *In essentially how many different ways can we colour the vertices of a cube if n colours are available?*
 5. *How many distinct chemical compounds are possible using 6 Carbon atoms, 3 Hydrogen and 3 Chlorine atoms? Note that these compounds are represented by the chemical formula $C_6H_3Cl_3$. For example two such compounds are given in Figure 6.*
 6. *Count the number of distinct colouring of the binary tree given in Figure 6 with 2 colours if we assume that the left and right configurations are indistinguishable.*

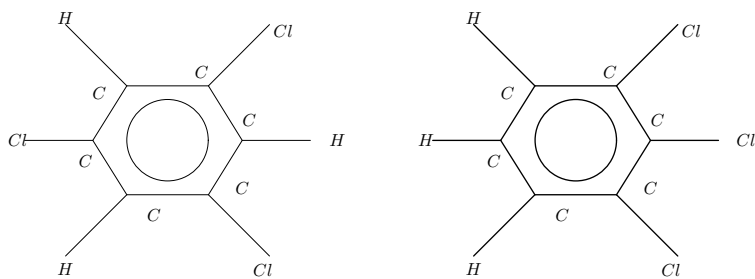
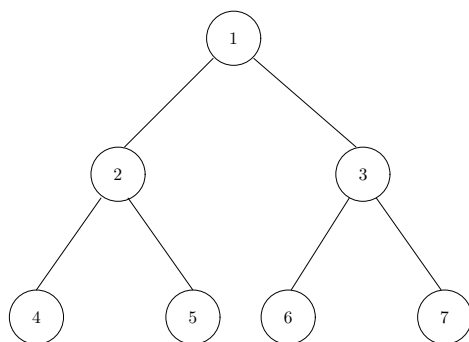
Two Distinct Configurations of $C_6H_3Cl_3$ 

A Binary Tree on 7 Vertices

7. Suppose that we have an unlimited supply of balls of n different colours. Also assume that p is a prime. Determine the number of distinct configurations that are possible if we place p balls on a circle. Recall that Fermat's Little Theorem states that p divides $n^p - n$. Does the above answer give another proof of Fermat's Little Theorem? Explain.

Chapter 4

Generating Functions and Its Applications

1 Formal Power Series

In this chapter, we will try to get closed form expressions for some known recurrence relations.

To do so, we first recall from Page 23 that the binomial coefficients, $\binom{n}{k}$ are also defined for all $n \in \mathbb{Q}$ and $k \in \mathbb{Z}$, $k \geq 0$. We also define the concept of “formal power series” and study its properties.

Definition 4.1.1 *An expression of the form $f(x) = \sum_{n \geq 0} a_n x^n$ is called a formal power series. The number a_0 is called the constant term of the series and a_n for $n \geq 1$ is called the coefficient of x^n .*

The set of all formal power series in the indeterminate x , will be denoted by $\mathcal{P}(x)$. We just think of them as algebraic expressions. We do not intend to evaluate the series for any value of x . In case, there is a need to evaluate the series, we will need to look at the notion of “radius of convergence” of a power series. In this chapter, our main aim is manipulate the series by means of algebraic rules. Before defining the algebraic rules, we need the following definition.

Definition 4.1.2 *Two elements $f(x) = \sum_{n \geq 0} a_n x^n$ and $g(x) = \sum_{n \geq 0} b_n x^n$ of $\mathcal{P}(x)$ are said to be equal if $a_n = b_n$ for all $n \geq 0$.*

We are now ready to define the algebraic rules:

Definition 4.1.3 *1. Let $f(x) = \sum_{n \geq 0} a_n x^n$ and $g(x) = \sum_{n \geq 0} b_n x^n$ be two elements of $\mathcal{P}(x)$. We*

define their sum/addition by

$$f(x) + g(x) = \sum_{n \geq 0} a_n x^n + \sum_{n \geq 0} b_n x^n = \sum_{n \geq 0} (a_n + b_n) x^n.$$

2. Let $f(x) = \sum_{n \geq 0} a_n x^n$ and $g(x) = \sum_{n \geq 0} b_n x^n$ be two elements of $\mathcal{P}(x)$. We define their product by

$$f(x) \cdot g(x) = \left(\sum_{n \geq 0} a_n x^n \right) \cdot \left(\sum_{n \geq 0} b_n x^n \right) = \sum_{n \geq 0} c_n x^n, \quad \text{where } c_n = \sum_{k=0}^n a_k b_{n-k} \text{ for } n \geq 0.$$

This product is also called the Cauchy product.

Remark 4.1.4 Note that the expression $e^{e^x - 1}$ is defined where as the expression e^{e^x} is not defined.

Thus, under the algebraic operations defined above, it can be checked that the set $\mathcal{P}(x)$ forms a *Commutative Ring* with identity, where the identity element is given by the formal power series $f(x) = 1$. In this ring, the element $f(x) = \sum_{n \geq 0} a_n x^n$ is said to have a *reciprocal* if there exists another element $g(x) = \sum_{n \geq 0} b_n x^n$ such that $f(x) \cdot g(x) = 1$.

In case, $f(x) \cdot g(x) = 1$, it *does not* mean that $f(x)$ and $g(x)$ as functions are inverse of each other. For them to be the inverse of each other, we need $(f \circ g)(x) = f(g(x)) = g(f(x)) = (g \circ f)(x) = x$. So, the questions arises, when can we talk about the reciprocal and inverse of an element $f(x) \in \mathcal{P}(x)$. The answer to these questions are given in the following propositions.

Proposition 4.1.5 Let $f(x) = \sum_{n \geq 0} a_n x^n \in \mathcal{P}(x)$.

1. Then there exists $g(x) \in \mathcal{P}(x)$ satisfying $f(x) \cdot g(x) = 1$ if and only if $a_0 \neq 0$.
2. Then there exists $g(x) \in \mathcal{P}(x)$ satisfying $(f \circ g)(x) = f(g(x)) = x$ if and only if either $f(x)$ is a polynomial or $a_0 = 0$ and $a_1 \neq 0$.

We now define the formal differentiation and integration of elements of $\mathcal{P}(x)$.

Definition 4.1.6 Let $f(x) = \sum_{n \geq 0} a_n x^n \in \mathcal{P}(x)$.

1. We define the formal differentiation of $f(x)$, denoted $Df(x)$ by

$$Df(x) = a_1 + 2a_2x + \cdots + na_nx^{n-1} + \cdots = \sum_{n \geq 1} na_nx^{n-1}.$$

2. We define the formal integration of $f(x)$, denoted $\text{Int} f(x) dx$ by

$$\text{Int} f(x) dx = a_0 x + a_1 \frac{x^2}{2} + \cdots + a_n \frac{x^{n+1}}{n+1} + \cdots = \sum_{n \geq 0} a_n \frac{x^{n+1}}{n+1}.$$

With the definitions as above the following proposition can be easily proved. So, we omit the proof.

Proposition 4.1.7 Let $f(x) = \sum_{n \geq 0} a_n x^n \in \mathcal{P}(x)$. Then

1. $f(x) = a_0$, a constant, whenever $Df(x) = 0$.
2. $f(x) = a_0 e^x$, whenever $Df(x) = f(x)$.

Before proceeding further, let us look at some important examples.

Example 4.1.8 1. Consider $\sum_{n \geq 0} x^n \in \mathcal{P}(x)$. We denote this element by $\frac{1}{1-x}$. That is, the coefficient of x^n in $\frac{1}{1-x}$, denoted $[x^n] \frac{1}{1-x}$, equals 1.

2. let r be a positive integer and consider the closed form expression $\frac{1}{(1-x)^r}$. Then, the coefficient of x^n in $\frac{1}{(1-x)^r}$, denoted $[x^n] \frac{1}{(1-x)^r}$, equals $\binom{n+r-1}{n}$.

3. Find a closed form expression for the element $\sum_{n \geq 0} n x^n \in \mathcal{P}(x)$.

Solution: As $\frac{1}{1-x} = \sum_{n \geq 0} x^n$, we have

$$\frac{1}{(1-x)^2} = D \left(\frac{1}{1-x} \right) = D \left(\sum_{n \geq 0} x^n \right) = \sum_{n \geq 0} n x^{n-1}.$$

Thus, the closed form expression is $\frac{x}{(1-x)^2}$.

4. Let $f(x) = \sum_{n \geq 0} a_n x^n \in \mathcal{P}(x)$. Find $\sum_{k=0}^n a_k$.

Solution: Recall that the Cauchy product of $f(x) = \sum_{n \geq 0} a_n x^n$ and $g(x) = \sum_{n \geq 0} b_n x^n$ is given

by $f(x) \cdot g(x) = \sum_{n \geq 0} c_n x^n$, where $c_n = \sum_{k=0}^n a_k b_{n-k}$ for $n \geq 0$.

So, to get $c_n = \sum_{k=0}^n a_k$, we need $b_k = 1$ for all $k \geq 0$. That is, c_n is the coefficient of x^n in the product $f(x) \cdot \frac{1}{1-x}$.

5. Find the sum of the squares of the first N positive integers.

Solution: From Example 4.1.8.2, observe that $k = [x^{k-1}] \left(\frac{1}{(1-x)^2} \right)$. So, by Example 4.1.8.4

$$\sum_{k=1}^N k = [x^{N-1}] \left(\frac{1}{(1-x)^2} \cdot \frac{1}{1-x} \right) = \binom{N-1+3-1}{N-1} = \frac{N(N+1)}{2}.$$

6. Find a closed form expression for $\sum_{k=1}^N k^2$.

Solution: From Example 4.1.8.3, observe that $\sum_{k \geq 0} kx^k = \frac{x}{(1-x)^2}$. So,

$$\sum_{k \geq 0} k^2 x^k = xD \left(\frac{x}{(1-x)^2} \right) = \frac{x(1+x)}{(1-x)^3}. \quad (4.1.1)$$

Thus, by Example 4.1.8.4

$$\begin{aligned} \sum_{k=1}^N k^2 &= [x^N] \left(\frac{x(1+x)}{(1-x)^3} \cdot \frac{1}{1-x} \right) = [x^{N-1}] \left(\frac{1}{(1-x)^4} \right) + [x^{N-2}] \left(\frac{1}{(1-x)^4} \right) \\ &= \binom{N-1+4-1}{N-1} + \binom{N-2+4-1}{N-2} \\ &= \frac{N(N+1)(2N+1)}{6}. \end{aligned}$$

7. Find a closed form expression for $\sum_{k=1}^N k^3$.

Solution: From (4.1.1), observe that $\sum_{k \geq 0} k^2 x^k = \frac{x(1+x)}{(1-x)^3}$. So,

$$\sum_{k \geq 0} k^3 x^k = xD \left(\frac{x(1+x)}{(1-x)^3} \right) = \frac{x(1+4x+x^2)}{(1-x)^4}.$$

Thus, by Example 4.1.8.4

$$\begin{aligned} \sum_{k=1}^N k^3 &= [x^N] \left(\frac{x(1+4x+x^2)}{(1-x)^4} \cdot \frac{1}{1-x} \right) \\ &= [x^{N-1}] \left(\frac{1}{(1-x)^5} \right) + [x^{N-2}] \left(\frac{4}{(1-x)^5} \right) + [x^{N-3}] \left(\frac{1}{(1-x)^5} \right) \\ &= \binom{N-1+5-1}{N-1} + 4 \binom{N-2+5-1}{N-2} + \binom{N-3+5-1}{N-3} \\ &= \left(\frac{N(N+1)}{2} \right)^2. \end{aligned}$$

Hence, we observe that we can inductively use this technique to get a closed form expression for $\sum_{k=1}^N k^r$ for any positive integer r .

8. Find a closed form expression for $\sum_{n \geq 0} \frac{n^2 + n + 6}{n!}$.

Solution: Observe that in this example, we are looking at an infinite sum. So, we cannot use Cauchy product to solve this problem. Also, we need to talk about the convergence of the series. Therefore, we recall that the series $e^x = \sum_{n \geq 0} \frac{x^n}{n!}$ converges for all $x \in \mathbb{R}$.

Now, we note that

$$\frac{n}{n!} = [x^n](xDe^x) = [x^n](xe^x), \quad \text{and} \quad \frac{n^2}{n!} = [x^n](xDxe^x) = [x^n]((x+x^2)e^x).$$

$$\text{Thus, } \sum_{n \geq 0} \frac{n^2 + n + 6}{n!} = (x+x^2)e^x + xe^x + 6e^x \Big|_{x=1} = 9e.$$

9. For two positive integers n and r , find the number of non-negative integer solutions to the system $x_1 + 2x_2 + \cdots + nx_n = r$?

Solution: Note that the given system can be rewritten as

$$x^r = x^{x_1+2x_2+\cdots+nx_n} = x^{x_1} \cdot x^{2x_2} \cdots x^{nx_n}$$

with the condition that the x_k 's are non-negative integers. Also, we know that for each k , $1 \leq k \leq n$, x^{kx_k} is a term in the expression

$$\frac{1}{1-x^k} = \sum_{i \geq 0} x^{ki}.$$

Hence, we are interested in computing the coefficient of x^r in

$$\frac{1}{(1-x)(1-x^2)\cdots(1-x^n)}.$$

10. For two positive integers n and r , find the number of non-negative integer solutions to the system $x_1 + 2x_2 + \cdots + nx_n \leq r$?

Solution: By Example 4.1.8.9 and Example 4.1.8.4, observe that we need to compute the coefficient of x^r in

$$\frac{1}{(1-x)(1-x^2)\cdots(1-x^n)} \cdot \frac{1}{1-x}.$$

We now look at some of the examples, in which it may be difficult to get a closed form expression for the numbers that we are interested in. But one can use the package MATHEMATICA to obtain the answer. So, in the examples that we give below, we are interested in getting a formal power series and then its coefficients give the answer to the questions raised.

Example 4.1.9 1. Show that $\sum_{k=1}^N \frac{1}{k}$ equals the coefficient of x^N in $\frac{1}{1-x} \cdot \ln\left(\frac{1}{1-x}\right)$.

Solution: Observe that, we need to compute $\frac{1}{k}$ as the coefficient of a formal power series and then use the Cauchy product formula (see Example 4). Now

$$\frac{1}{k} = [x^k] \left(\sum_{n \geq 1} \frac{x^n}{n} \right) = [x^k] \left(\text{Int} \frac{1}{1-x} \right) = [x^k] \left(\ln \left(\frac{1}{1-x} \right) \right).$$

Thus, the result follows.

2. How many non-negative integer solutions are there to the system $x_1 + x_2 + \cdots + x_5 = n$ such that $x_1 \geq 4$, $x_4 \leq 10$ and for $r \neq 1, 4$, x_r is a multiple of r .

Solution: Note that the condition $x_1 \geq 4$ corresponds to looking at x^k for $k \geq 4$. That is, the condition $x_1 \geq 4$ gives us the formal power series $\sum_{k \geq 4} x^k$. Similarly, $x_4 \leq 10$ gives

the formal power series $\sum_{k=0}^{10} x^k$ and the condition x_r is a multiple of r , for $r \neq 1, 4$, gives the formal power series $\sum_{k \geq 0} x^{rk}$. So, we are interested in computing the coefficient of x^n in the product

$$\left(\sum_{k \geq 4} x^k \right) \cdot \left(\sum_{k=0}^{10} x^k \right) \cdot \left(\sum_{k \geq 0} x^{2k} \right) \cdot \left(\sum_{k \geq 0} x^{3k} \right) \cdot \left(\sum_{k \geq 0} x^{5k} \right) = \frac{x^4(1-x^{11})}{(1-x)^2(1-x^2)(1-x^3)(1-x^5)}.$$

3. In how many ways 100 voters cast their 100 votes for 10 candidates such that no candidate gets more than 20 votes.

Solution: Note that we are assuming that the voters are identical. So, we need to solve the system in non-negative integers to the system $x_1 + x_2 + \cdots + x_{10} = 100$, with $0 \leq x_i \leq 20$ for $1 \leq i \leq 10$. So, we need to find the coefficient of x^{100} in

$$\begin{aligned} \left(\sum_{k=1}^{20} x^k \right)^{10} &= \frac{(1-x^{21})^{10}}{(1-x)^{10}} = \left(\sum_{i=0}^{10} (-1)^i \binom{10}{i} x^{21i} \right) \cdot \left(\sum_{j \geq 0} \binom{10+j-1}{j} x^j \right) \\ &= \sum_{i=0}^4 (-1)^i \binom{10}{i} \cdot \binom{109-21i}{9}. \end{aligned}$$

Exercise 4.1.10 For fixed positive integers m, n , and r , give reasons to prove that the following problems are equivalent?

1. How many non-negative integer solutions are there to the system

$$x_1 + x_2 + \cdots + x_n = r \quad \text{with} \quad m \leq x_i \leq 2m?$$

2. How many ways are there to put r indistinguishable balls into n distinguishable boxes so that the number of balls in each box any number between m and $2m$ (endpoints included)?
3. What is the coefficient of x^r in the formal power series $\frac{x^{mn} (1 - x^{m+1})^n}{(1 - x)^n}$?

We now look at the applications of generating functions/formal power series to the solution of recurrence relations.

2 Recurrence Relation

We demonstrate the applications using the following examples.

Example 4.2.1 1. Determine a formula for the numbers $a(n)$'s, where $a(n)$'s satisfy the following recurrence relation:

$$a(n) = 3a(n-1) + 2n, \quad \text{for } n \geq 1 \quad \text{with } a(0) = 1. \quad (4.2.1)$$

Solution: Define $A(x) = \sum_{n \geq 0} a(n)x^n$. Then using the recurrence relation, we have

$$\begin{aligned} A(x) &= \sum_{n \geq 0} a(n)x^n = \sum_{n \geq 1} (3a(n-1) + 2n)x^n + 1 \\ &= 3x \sum_{n \geq 1} a(n-1)x^{n-1} + 2 \sum_{n \geq 1} nx^n + 1 = 3xA(x) + 2 \frac{x}{(1-x)^2} + 1. \end{aligned}$$

So, $A(x) = \frac{1+x^2}{(1-3x)(1-x)^2} = \frac{5}{2(1-3x)} - \frac{1}{2(1-x)} - \frac{1}{(1-x)^2}$. Thus,

$$a(n) = [x^n]A(x) = \frac{5}{2}3^n - \frac{1}{2} - (n+1) = \frac{5 \cdot 3^n - 1}{2} - (n+1).$$

2. Determine a generating function for the numbers $f(n)$ that satisfy the recurrence relation

$$f(n) = f(n-1) + f(n-2), \quad \text{for } n \geq 2 \quad \text{with } f(0) = 1 \quad \text{and } f(1) = 1. \quad (4.2.2)$$

Hence or otherwise find a formula for the numbers $f(n)$.

Solution: Define $F(x) = \sum_{n \geq 0} f(n)x^n$. Then using the recurrence relation, we have

$$\begin{aligned} F(x) &= \sum_{n \geq 0} f(n)x^n = \sum_{n \geq 2} (f(n-1) + f(n-2))x^n + 1 + x \\ &= x \sum_{n \geq 2} f(n-1)x^{n-1} + x^2 \sum_{n \geq 2} f(n-2)x^{n-2} + 1 + x = xF(x) + x^2F(x) + 1. \end{aligned}$$

So,

$$F(x) = \frac{1}{1-x-x^2}.$$

Let $\alpha = \frac{1+\sqrt{5}}{2}$ and $\beta = \frac{1-\sqrt{5}}{2}$. Then it can be checked that $(1-\alpha x)(1-\beta x) = 1-x-x^2$ and

$$F(x) = \frac{1}{\sqrt{5}} \left(\frac{\alpha}{1-\alpha x} - \frac{\beta}{1-\beta x} \right) = \frac{1}{\sqrt{5}} \left(\sum_{n \geq 0} \alpha^{n+1} x^n - \sum_{n \geq 0} \beta^{n+1} x^n \right).$$

Therefore,

$$f(n) = [x^n]F(x) = \frac{1}{\sqrt{5}} \sum_{n \geq 0} (\alpha^{n+1} - \beta^{n+1}).$$

As $\beta < 0$ and $|\beta| < 1$, we observe that

$$f(n) \approx \frac{1}{\sqrt{5}} \left(\frac{1+\sqrt{5}}{2} \right)^{n+1}.$$

Remark 4.2.2 The numbers $f(n)$ for $n \geq 0$ are called FIBONACCI NUMBERS. It is related with the following problem:

Suppose a couple bought a pair of rabbits (each one year old) in the year 2001. If a pair of rabbits start giving birth to a pair of rabbits as soon as they grow 2 years old, determine the number of rabbits the couple will have in the year 2025.

3. Suppose n, m are non-negative integers. Determine a generating function for the numbers $f(n, m)$ that satisfy the recurrence relation

$$\begin{aligned} f(n, m) &= f(n-1, m) + f(n-1, m-1), \quad (n, m) \neq (0, 0) \quad \text{with} \quad (4.2.3) \\ f(n, 0) &= 1 \quad \text{for all } n \geq 0 \quad \text{and} \quad f(0, m) = 0 \quad \text{for all } m > 0. \end{aligned}$$

Hence or otherwise find a formula for the numbers $f(n, m)$.

Solution: Before we start with the solution, note that in the above recurrence relation, the value of m need not be $\leq n$.

METHOD 1: Define $F_n(x) = \sum_{m \geq 0} f(n, m)x^m$. Then for $n \geq 1$, the use of (4.2.3) gives

$$\begin{aligned} F_n(x) &= \sum_{m \geq 0} f(n, m)x^m = \sum_{m \geq 0} (f(n-1, m) + f(n-1, m-1))x^m \\ &= \sum_{m \geq 0} f(n-1, m)x^m + \sum_{m \geq 0} f(n-1, m-1)x^m \\ &= F_{n-1}(x) + xF_{n-1}(x) = (1+x)F_{n-1}(x) = \cdots = (1+x)^n F_0(x). \end{aligned}$$

As $F_0(x) = 1$, we get $F_n(x) = (1+x)^n$. Hence

$$f(n, m) = [x^m](1+x)^n = \binom{n}{m} \quad \text{if } 0 \leq m \leq n \quad \text{and} \quad f(n, m) = 0 \quad \text{for } m > n.$$

METHOD 2: Define $G_m(y) = \sum_{n \geq 0} f(n, m)y^n$. Then for $m \geq 1$, the use of (4.2.3) gives

$$\begin{aligned} G_m(y) &= \sum_{n \geq 0} f(n, m)y^n = \sum_{n \geq 0} (f(n-1, m) + f(n-1, m-1))y^n \\ &= \sum_{n \geq 0} f(n-1, m)y^n + \sum_{n \geq 0} f(n-1, m-1)y^n \\ &= yG_m(y) + yG_{m-1}(y). \end{aligned}$$

Therefore, $G_m(y) = \frac{y}{1-y}G_{m-1}(y)$. As $G_0(y) = \frac{1}{1-y}$, we get

$$G_m(y) = \frac{y^m}{(1-y)^{m+1}}.$$

Hence

$$f(n, m) = [y^n] \frac{y^m}{(1-y)^{m+1}} = [y^{n-m}] \frac{1}{(1-y)^{m+1}} = \binom{n}{m} \\ \text{if } 0 \leq m \leq n \text{ and } f(n, m) = 0 \text{ for } m > n.$$

4. Suppose n, m are non-negative integers. Determine a generating function for the numbers $S(n, m)$ that satisfy the recurrence relation

$$\begin{aligned} S(n, m) &= mS(n-1, m) + S(n-1, m-1), \quad (n, m) \neq (0, 0) \quad \text{with} \quad (4.2.4) \\ S(0, 0) &= 1, S(n, 0) = 0 \text{ for all } n > 0 \text{ and } S(0, m) = 0 \text{ for all } m > 0. \end{aligned}$$

Hence or otherwise find a formula for the numbers $S(n, m)$.

Solution: Define $G_m(y) = \sum_{n \geq 0} S(n, m)y^n$. Then for $m \geq 1$, the use of (4.2.4) gives

$$\begin{aligned} G_m(y) &= \sum_{n \geq 0} S(n, m)y^n = \sum_{n \geq 0} (mS(n-1, m) + S(n-1, m-1))y^n \\ &= m \sum_{n \geq 0} S(n-1, m)y^n + \sum_{n \geq 0} S(n-1, m-1)y^n \\ &= myG_m(y) + yG_{m-1}(y). \end{aligned}$$

Therefore, $G_m(y) = \frac{y^m}{1-my}G_{m-1}(y)$. As $G_0(y) = 1$, we get

$$G_m(y) = \frac{y^m}{(1-y)(1-2y) \cdots (1-my)} = y^m \sum_{k=1}^m \frac{\alpha_k}{1-ky}, \quad (4.2.5)$$

where $\alpha_k = \frac{(-1)^{m-k} k^m}{k! (m-k)!}$ for $1 \leq k \leq m$. Hence

$$S(n, m) = [y^n] \left(y^m \sum_{k=1}^m \frac{\alpha_k}{1-ky} \right) = \sum_{k=1}^m [y^{n-m}] \frac{\alpha_k}{1-ky} \quad (4.2.6)$$

$$= \sum_{k=1}^m \alpha_k k^{n-m} = \sum_{k=1}^m \frac{(-1)^{m-k} k^n}{k! (m-k)!}. \quad (4.2.7)$$

Or equivalently, $S(n, m) = \sum_{k=1}^m \frac{(-1)^{m-k} k^{n-1}}{(k-1)! (m-k)!}$. Also,

$$m! S(n, m) = \sum_{k=1}^m m! \frac{(-1)^{m-k} k^n}{k! (m-k)!} = \sum_{k=1}^m (-1)^{m-k} \binom{m}{k} k^n.$$

The above expression was already obtained earlier (see (1.1.1) and Exercise 5). This identity is generally known as the STIRLING'S IDENTITY.

Observation:

(a) We have not considered $H_n(x) = \sum_{m \geq 0} S(n, m)x^m$. If we do so, it can be checked that we will obtain

$$H_n(x) = (x + xD)^n \cdot 1 \quad \text{as} \quad H_0(x) = 1.$$

Therefore, $H_1(x) = x$, $H_2(x) = x + x^2, \dots$. From this it is difficult to obtain a general formula for its coefficients. But we will use this to show that if n is fixed then the numbers $S(n, m)$ first increase and then decrease. That is, for fixed n , the sequence $\{S(n, m)\}_{m=0}^n$ is unimodal. The same holds for $\{\binom{n}{m}\}_{m=0}^n$, the sequence of binomial coefficients.

(b) Note that in the above recurrence relation, we have not put any restriction on the n and m . So, the expression (4.2.6) is valid even when $n < m$. In this case, we know that $S(n, m) = 0$. Hence, it can be checked that $\sum_{k=1}^m \frac{(-1)^{m-k} k^{n-1}}{(k-1)! (m-k)!} = 0$ whenever $n < m$.

5. We are now ready to study "Bell Numbers". For a positive integer n , the n^{th} Bell number, denoted $b(n)$, is the number of partitions of the set $\{1, 2, \dots, n\}$. So, by definition, it follows that $b(n) = \sum_{m=1}^n S(n, m)$ for $n \geq 1$ and by the convention (for Stirling Numbers), $b(0) = 1$. From the above observation, we have

$$\begin{aligned} b(n) &= \sum_{m=1}^n S(n, m) = \sum_{m \geq 1} S(n, m) = \sum_{m \geq 1} \sum_{k=1}^m \frac{(-1)^{m-k} k^{n-1}}{(k-1)! (m-k)!} \\ &= \sum_{k \geq 1} \frac{k^n}{k!} \sum_{m \geq k} \frac{(-1)^{m-k}}{(m-k)!} = \frac{1}{e} \sum_{k \geq 1} \frac{k^n}{k!}. \end{aligned} \quad (4.2.8)$$

We will now find the exponential generating function for Bell numbers and use it to get the recurrence relation (see Exercise 1.1.17.5). Define $B(x) = \sum_{n \geq 0} b(n) \frac{x^n}{n!}$. Observe that

we need to write $B(x) = 1 + \sum_{n \geq 1} b(n) \frac{x^n}{n!}$ as the recurrence relation for $S(n, k)$ was valid only when $(n, k) \neq (0, 0)$. So,

$$\begin{aligned}
 B(x) &= 1 + \sum_{n \geq 1} b(n) \frac{x^n}{n!} = 1 + \sum_{n \geq 1} \left(\frac{1}{e} \sum_{k \geq 1} \frac{k^n}{k!} \right) \frac{x^n}{n!} \\
 &= 1 + \frac{1}{e} \sum_{k \geq 1} \frac{1}{k!} \sum_{n \geq 1} k^n \frac{x^n}{n!} = 1 + \frac{1}{e} \sum_{k \geq 1} \frac{1}{k!} \sum_{n \geq 1} \frac{(kx)^n}{n!} \\
 &= 1 + \frac{1}{e} \sum_{k \geq 1} \frac{1}{k!} (e^{kx} - 1) = 1 + \frac{1}{e} \sum_{k \geq 1} \left(\frac{(e^x)^k}{k!} - \frac{1}{k!} \right) \\
 &= 1 + \frac{1}{e} (e^{e^x} - 1 - (e - 1)) = e^{e^x - 1}. \tag{4.2.9}
 \end{aligned}$$

Note that $e^{e^x - 1}$ is a valid formal power series. We are now ready to derive the recurrence relation for $b(n)$'s. Taking the natural logarithm on both the sides of (4.2.9), we have

$$\text{Ln} \left(\sum_{n \geq 0} b(n) \frac{x^n}{n!} \right) = e^x - 1.$$

Now, we make the following sequence of operations (differentiating with respect to x , multiplying by x and cross multiplication), to obtain

$$\sum_{n \geq 1} n \frac{b(n)x^n}{n!} = x e^x \sum_{n \geq 0} b(n) \frac{x^n}{n!} = x \left(\sum_{m \geq 0} \frac{x^m}{m!} \right) \cdot \left(\sum_{n \geq 0} b(n) \frac{x^n}{n!} \right).$$

Thus,

$$\frac{b(n)}{(n-1)!} = [x^n] \sum_{n \geq 1} n \frac{b(n)x^n}{n!} = [x^n] x \left(\sum_{m \geq 0} \frac{x^m}{m!} \right) \cdot \left(\sum_{n \geq 0} b(n) \frac{x^n}{n!} \right) = \sum_{m=0}^{n-1} \frac{1}{(n-1-m)!} \cdot \frac{b(m)}{m!}.$$

Hence, we have the required result. That is,

$$b(n) = \sum_{m=0}^{n-1} \binom{n-1}{m} b(m) \quad \text{for } n \geq 1 \quad \text{and } b(0) = 1.$$

6. Determine the number of ways of arranging n pairs of parentheses (left and right) such that at any stage the number of right parentheses is always less than or equal to the number of left parentheses.

Solution: Recall from Page 20 that this number is the n^{th} Catalan number. Here, we will use recurrence relation to solve this problem. To do so, we first define the following.

An arrangement of n pairs of parentheses (left and right) is called a **VALID n -ARRANGEMENT** if at any stage the number of right parentheses is always less than or equal to the number of left parentheses. A valid n -arrangement is called **n -SPECIAL** if for each $k < n$, in the first $2k$ stages, the number of left parentheses is strictly greater than the number of right parentheses. Let us denote the number of valid n -arrangement by $f(n)$ and the number of n -special arrangements by $g(n)$.

Claim: $g(1) = 1$ and for $n \geq 2$, $g(n) = f(n - 1)$.

Clearly $g(1) = 1$. Note that for $n \geq 2$, an n -special arrangement, necessarily starts with two left parentheses and ends with two right parentheses. So, if we remove the first left parenthesis and the last right parenthesis, we will be left with a valid $(n - 1)$ -arrangement. In a similar way, if we add one left parenthesis at the beginning and a right parenthesis at the end of a valid $(n - 1)$ -arrangement then we will get an n -special arrangement. Thus the proof of the claim is complete.

Consider a valid n -arrangement. Then for some k , $1 \leq k \leq n$ the first k pairs of parentheses will form a k -special arrangement and the remaining $(n - k)$ pairs of parenthesis will form a valid $(n - k)$ -arrangement. Hence if we take $f(0) = g(1) = 1$, we have

$$f(n) = \sum_{k=1}^n g(k)f(n - k) = \sum_{k=1}^n f(k - 1)f(n - k), \quad \text{for } n \geq 2.$$

Define $F(x) = \sum_{n \geq 0} f(n)x^n$. Then

$$\begin{aligned} F(x) &= \sum_{n \geq 0} f(n)x^n = 1 + \sum_{n \geq 1} f(n)x^n = 1 + \sum_{n \geq 1} \left(\sum_{k=1}^n f(k - 1)f(n - k) \right) x^n \\ &= 1 + x \left(\sum_{k \geq 1} f(k - 1)x^{k-1} \sum_{n \geq k} f(n - k)x^{n-k} \right) \\ &= 1 + x \left(F(x) \sum_{k \geq 1} f(k - 1)x^{k-1} \right) = 1 + x(F(x))^2. \end{aligned}$$

Thus, we get $x(F(x))^2 - F(x) + 1 = 0$. Hence, $F(x) = \frac{1 \pm \sqrt{1 - 4x}}{2x}$. But the condition $F(0) = 1$ implies that

$$F(x) = \frac{1 - \sqrt{1 - 4x}}{2x}.$$

Therefore,

$$\begin{aligned}
 f(n) &= [x^n]F(x) = \frac{1}{2} \cdot [x^{n+1}] (1 - \sqrt{1 - 4x}) \\
 &= -\frac{1}{2} \cdot \frac{\frac{1}{2} \left(\frac{1}{2} - 1\right) \left(\frac{1}{2} - 2\right) \cdots \left(\frac{1}{2} - n\right)}{(n+1)!} (-4)^{n+1} \\
 &= 2(-4)^n \cdot \frac{1 \cdot (-1) \cdot (-3) \cdot (-5) \cdots (1 - 2n)}{2^{n+1}(n+1)!} = 2^n \frac{1 \cdot 3 \cdot 5 \cdots (2n-1)}{(n+1)!} \\
 &= \frac{1}{n+1} \binom{2n}{n}, \quad \text{the } n^{\text{th}} \text{ Catalan Number.}
 \end{aligned}$$

Exercise 4.2.3 1. A man at each step either climbs one stair or two stairs. Suppose the man has to climb a staircase consisting of n stairs. Determine the number of ways in which he can climb the staircase.

2. Let a_n denote the number of sequences of length n that consist of the digits 0, 1, 2 and 3 and that do not have two consecutive appearances of 0's.

3. Suppose a person has n rupees. The person can either buy a toffee worth 1 rupee or a chocolate worth 2 rupees or an icecream worth 3 rupees. Determine the number of ways in which he can spend n rupees.

4. Let $f(n, k)$ denote the number of k -element subsets that can be selected from the set $\{1, 2, \dots, n\}$ and that do not contain two consecutive integers. Find a recurrence relation for $f(n, k)$'s and hence determine the value of $f(n, k)$. $= f(n-1, k) + f(n-2, k-1) = \frac{n}{n-k} \binom{n-k+1}{k}$. Recall that this problem also appeared in Miscellaneous Exercises on Page 15 in a different form.

5. Suppose the numbers $\{1, 2, \dots, n\}$ are arranged in a round table. Let $g(n, k)$ denote the number of k -element subsets that can be selected from this round table with the condition that no two consecutive integers appear. Find a recurrence relation for $g(n, k)$'s and hence determine the value of $g(n, k)$. $= f(n-1, k) + f(n-3, k-1) = \frac{n}{n-k} \binom{n-k}{k}$.

3 Applications of Generating Functions

We will now use the ideas learnt in the above sections to get closed form expressions for sums arising out of binomial coefficients. To do so, we will need to recall the following important sums. The readers are requested to get proof of the identities given below.

- $\sum_{k \geq 0} \binom{n}{k} = 2^n$.

2. $\sum_{k \geq 0} \binom{n}{k} x^k = (1+x)^n$.
3. $\sum_{k \geq -r} \binom{n}{r+k} x^k = x^{-r} \sum_{r+k \geq 0} \binom{n}{r+k} x^{r+k} = x^{-r} (1+x)^n$.
4. $\sum_{r \geq k} \binom{r}{k} x^r = \frac{x^k}{(1-x)^{k+1}}$ for $k \geq 0$.
5. $\sum_{n \geq 0} \frac{1}{n+1} \binom{2n}{n} x^n = \frac{1}{2x} (1 - \sqrt{1-4x})$.

Example 4.3.4 1. Find a closed form expression for the numbers $a(n) = \sum_{k \geq 0} \binom{k}{n-k}$.

Solution: Define $A(x) = \sum_{n \geq 0} a(n)x^n$. Then

$$\begin{aligned}
 A(x) &= \sum_{n \geq 0} a(n)x^n = \sum_{n \geq 0} \left(\sum_{k \geq 0} \binom{k}{n-k} \right) x^n \\
 &= \sum_{k \geq 0} \left(\sum_{n \geq 0} \binom{k}{n-k} x^n \right) = \sum_{k \geq 0} x^k \left(\sum_{n \geq k} \binom{k}{n-k} x^{n-k} \right) \\
 &= \sum_{k \geq 0} x^k (1+x)^k = \sum_{k \geq 0} (x(1+x))^k \\
 &= \frac{1}{1-x(1+x)}.
 \end{aligned}$$

Therefore, from Example 4.2.1.2, we have

$$a(n) = [x^n]A(x) = [x^n] \frac{1}{1-x(1+x)} = F_n, \quad \text{the } n^{\text{th}} \text{ Fibonacci number.}$$

2. Find a closed form expression for the polynomials $a(n, x) = \sum_{k=0}^{\lfloor \frac{n}{2} \rfloor} \binom{n-k}{k} (-1)^k x^{n-2k}$.

Solution: Define $A(x, y) = \sum_{n \geq 0} a(n, x)y^n$. Then

$$\begin{aligned}
 A(x, y) &= \sum_{n \geq 0} a(n, x)y^n = \sum_{n \geq 0} \left(\sum_{k=0}^{\lfloor \frac{n}{2} \rfloor} \binom{n-k}{k} (-1)^k x^{n-2k} \right) y^n \\
 &= \sum_{k \geq 0} (-1)^k y^{2k} \left(\sum_{n \geq 2k} \binom{n-k}{k} (xy)^{n-2k} \right) \\
 &= \sum_{k \geq 0} (-1)^k y^{2k} (xy)^{-k} \left(\sum_{t \geq k} \binom{t}{k} (xy)^t \right) \\
 &= \sum_{k \geq 0} (-y^2)^k (xy)^{-k} \frac{(xy)^k}{(1-xy)^{k+1}} = \frac{1}{1-xy} \cdot \sum_{k \geq 0} \left(\frac{-y^2}{1-xy} \right)^k \\
 &= \frac{1}{1-xy} \cdot \frac{1}{1 - \frac{-y^2}{1-xy}} = \frac{1}{1-xy+y^2}.
 \end{aligned}$$

Let $1 - xy + y^2 = (1 - \alpha y)(1 - \beta y)$, where $\alpha = \frac{x + \sqrt{x^2 - 4}}{2}$ and $\beta = \frac{x - \sqrt{x^2 - 4}}{2}$. Therefore,

$$\begin{aligned}
 a(n, x) &= [y^n]A(x, y) = [y^n] \frac{1}{1-xy+y^2} = [y^n] \frac{1}{\alpha - \beta} \left(\frac{\alpha}{1 - \alpha y} - \frac{\beta}{1 - \beta y} \right) \\
 &= \frac{1}{\alpha - \beta} (\alpha^{n+1} - \beta^{n+1}) \\
 &= \frac{1}{\sqrt{x^2 - 4}} \left(\left(\frac{x + \sqrt{x^2 - 4}}{2} \right)^{n+1} - \left(\frac{x - \sqrt{x^2 - 4}}{2} \right)^{n+1} \right).
 \end{aligned}$$

As α and β are the roots of the equation $y^2 - xy + 1 = 0$, we get $\alpha^2 = \alpha x - 1$ and $\beta^2 = \beta x - 1$. Therefore, it can be checked that the $a(n, x)$'s satisfy the recurrence relation $a(n, x) = xa(n-1, x) - a(n-2, x)$, for $n \geq 2$ with $a(0, x) = 1$, and $a(1, x) = x$.

This recurrence relation also appears as the characteristic polynomial of an $n \times n$ matrix $A = (a_{ij})$, where $a_{ij} = \begin{cases} 1, & \text{if } |i - j| = 1, \\ 0, & \text{otherwise.} \end{cases}$ This matrix is the adjacency matrix of a tree T on n vertices where the vertices are labeled v_1, v_2, \dots, v_n and the vertex v_i is adjacent to the vertex v_{i+1} for $1 \leq i \leq n-1$. That is,

$$a(n, x) = \det(xI_n - A).$$

The polynomials $a(n, x)$'s are also called CHEBYSHEV'S polynomial of second kind. We will now substitute different values for x and obtain expressions in each case.

(a) Let $x = z + \frac{1}{z}$. Then $\sqrt{x^2 - 4} = z - \frac{1}{z}$ and we obtain $a(n, z + \frac{1}{z}) = \frac{z^{2n+2} - 1}{(z^2 - 1)z^n}$. Hence,

we have $\sum_{k=0}^{\lfloor \frac{n}{2} \rfloor} \binom{n-k}{k} (-1)^k (z + \frac{1}{z})^{n-2k} = \frac{z^{2n+2} - 1}{(z^2 - 1)z^n}$. Or equivalently,

$$\sum_{k=0}^{\lfloor \frac{n}{2} \rfloor} \binom{n-k}{k} (-1)^k (z^2 + 1)^{n-2k} z^{2k} = \frac{z^{2n+2} - 1}{z^2 - 1}.$$

(b) Writing x in place of z^2 , we obtain the following identity.

$$\sum_{k=0}^{\lfloor \frac{n}{2} \rfloor} \binom{n-k}{k} (-1)^k (x+1)^{n-2k} x^k = \frac{x^{n+1} - 1}{x - 1} = \sum_{k=0}^n x^k. \quad (4.3.10)$$

(c) Hence, equating the coefficient of x^m in (4.3.10), we have

$$\sum_{k=0}^{\lfloor \frac{n}{2} \rfloor} (-1)^k \binom{n-k}{k} \binom{n-2k}{m-k} = \begin{cases} 1, & \text{if } 0 \leq m \leq n; \\ 0, & \text{otherwise.} \end{cases}$$

(d) Also, if we substitute $x = 1$ in (4.3.10), we get $\sum_{k=0}^{\lfloor \frac{n}{2} \rfloor} (-1)^k \binom{n-k}{k} 2^{n-2k} = n + 1$.

Exercise 4.3.5 1. Let n be a non-negative integer. Prove the Reed Dawson's identity

$$\frac{1}{k+1} \sum_{k \geq 0} \binom{n}{k} \binom{2k}{k} (-1)^k 2^{-k} = \begin{cases} \binom{n}{n/2}, & \text{if } n \text{ is even;} \\ 0, & \text{otherwise.} \end{cases}$$

2. Let $m, n \in \mathbb{N}$. Then prove that $\sum_{k \geq 0} \binom{n+k}{m+2k} \binom{2k}{k} \frac{(-1)^k}{k+1} = \binom{n-1}{m-1}$.

3. Let n be a non-negative integer. Prove that $\sum_{k \geq 0} \binom{n+k}{2k} 2^{n-k} = \frac{2^{2n+1} + 1}{3}$.

4. Let $m, n \in \mathbb{N}$. Determine whether or not the following identities are correct.

(a) $\sum_{k \geq 0} \binom{m}{k} \cdot \binom{n+k}{m} = \sum_{k \geq 0} \binom{m}{k} \cdot \binom{n}{k} 2^k$.

(b) $\sum_{k=0}^n (-1)^k \binom{m+1}{k} \binom{m+n-k}{m} = \begin{cases} 1, & \text{if } n = 0, \\ 0, & \text{if } n > 0. \end{cases}$

(c) $\sum_{k=m+1}^n (-1)^k \binom{n}{k} \binom{k-1}{m} = (-1)^{m+1}$.

5. Determine whether or not the following statement is correct.

$$\sum_{k=1}^n \frac{(-1)^{k+1}}{k} \binom{n}{k} = \sum_{k=1}^n \frac{1}{k}.$$

Notes: Most of the ideas for this chapter have come from book [8].

Chapter 5

Answers and Hints

1 Counting and Permutations

Answers to Questions on Page 5.

(1) $30 + 20 = 50$.

(2) $3 \times 2 \times 3 = 18$.

(3) The first place has 21 choices (there are 21 consonants), the second place has 5 choices (there are 5 vowels) and the third and the fourth places have 26 choices each (no restriction). Hence, the answer is $21 \cdot 5 \cdot 26 \cdot 26$.

(4) The word *CAD* may start at the first place or the second place and the third place. As we need 5 letter words, there are two places left after using the places for the word *CAD*. So, the number of words that have *CAD* are $3 \cdot 4^2$. So, the answer is $4^5 - 3 \cdot 4^2$.

Answers to Questions on Page 6.

(1) This is same as looking at all functions $f : \{1, 2, 3\} \longrightarrow \{a, b, \dots, z\}$. And therefore by Example 1.1.1, this number is 26^3 .

(2) When we throw a dice, an outcome is an element of the set $\{1, 2, 3, 4, 5, 6\}$. So, the problem reduces to “find the number of functions $f : \{1, 2, \dots, k\} \longrightarrow \{1, 2, 3, 4, 5, 6\}$. So, the answer is 6^k .

Answers to Questions on Page 7

- (1) All one-one functions $f : \{1, 2, 3\} \rightarrow \{a, b, \dots, z\}$. So, the answer is $26 \cdot 25 \cdot 24 = \frac{26!}{23!}$.
- (2) All one-one functions $f : \{1, 2, 3\} \rightarrow \{c_1, c_2, c_3, c_4, c_5\}$. So, the answer is $\frac{5!}{2!}$.
- (3) All one-one functions $f : \{1, 2, 3, 4, 5\} \rightarrow \{c_1, c_2, c_3, c_4, c_5\}$. So, the answer is $5!$.
- (4) All one-one functions $f : \{1, 2, 3, 4, 5\} \rightarrow \{A_1, A_2, A_3, E_4, E_5\}$. So, the answer is $5!$.
- (5) As Ram and Shyam are sitting next to each other, they can be thought of as one person. So, we need to arrange 7 people with the understanding that Ram and Shyam give rise to $2!$ ways for themselves. So, the answer is $2! \cdot 7!$.

Answers to Questions on Page 8

- (1) $\binom{6}{5}$, as we are picking a subset of size 5 from a set with 6 elements.
- (2) $\binom{8}{2}$, as we are picking a subset of size 2 from a set with $8 = 5 + 3$ elements.
By another method: The two students can both be boys, or can both be girls or one boy and one girl. So, we have $\binom{5}{2} + \binom{3}{2} + \binom{5}{1} \cdot \binom{3}{1} = \binom{8}{2}$.
- (3) $\binom{15}{7}$. Reasoning, same as that of Question 1.1.9.2.
- (4) $\binom{11}{5}$.
- (5) $\binom{3}{1} \cdot \binom{4}{1} \cdot \binom{5}{1}$.
- (6) Out of the five places, choose 2 places for D 's. This can be done in $\binom{5}{2}$ ways. At the three positions, the letters A, B, C can be arranged in $3!$ ways. So, the answer is $3! \cdot \binom{5}{2} = \frac{5!}{2!}$.
- (7) Out of the five places, choose 2 places for D 's. This can be done in $\binom{5}{2}$ ways. This also fixes the places for A 's. Hence, the answer is $\binom{5}{2}$.
- (8) Out of 11 places, $\binom{11}{2}$ for the M 's, out of the remaining 9 places, $\binom{9}{2}$ for the A 's, out of the remaining 7 places, $\binom{7}{2}$ for the T 's and the remaining 5 places for the letters C, E, H, I and S . These 5 letters can be arranged in $5!$ ways. So, the answer is

$$5! \cdot \binom{11}{2} \cdot \binom{9}{2} \cdot \binom{7}{2}.$$

- (9) A similar reasoning as that of Question 1.1.9.8 gives the answer as

$$3! \cdot \binom{19}{6} \cdot \binom{13}{6} \cdot \binom{7}{2} \cdot \binom{5}{2}.$$

(10) $2^{10} - 1$, as at least one friend has to be invited.

Answers to Questions on Page 10.

(1) Let $S = \{a_1, a_2, \dots, a_n\}$.

- (a) Suppose we need to make a committee of r people. Then a_n is in the committee or not. If a_n is in the committee then we need to choose $r - 1$ people from the remaining $n - 1$ people. If a_n is not in the committee then we need to choose k people from the remaining $n - 1$ people to get a committee consisting of k people in which a_n is not a member.
- (b) Let us count all sets of the form $\{x, A\}$ such that $A \subset S$, $x \in A$ and $|A| = k$. There are $\binom{n}{k}$ ways of choosing the set A and then there are k choices of x . Or we can choose x in n ways from the set S and then there are $\binom{n-1}{k-1}$ ways of building the remaining $k - 1$ elements from $S - \{x\}$ to get the set A such that $x \in A$.
- (c) Let us count all sets of the form $\{B, A\}$ such that $B \subset A \subset S$, $|B| = \ell$, $|A| = k$ and $\ell \leq k$. Now proceed as in the above exercise.
- (d) Use the previous identity.
- (e) A repeated application of Pascal's identity with the observation that $\binom{n+1}{0} = \binom{n}{0}$.
- (f) A repeated application of Pascal's identity. Or you can try some substitution in the above identity.

Try this yourself: **Van der monde's Identity**

$$\sum_{\ell=0}^k \binom{n}{\ell} \binom{w}{k-\ell} = \binom{n+w}{k}.$$

(2) Fix an element $a \in X$. Define a map $f_a : X_{\text{O}} \rightarrow X_{\text{e}}$ by

$$f_a(S) = \begin{cases} S \cup \{a\} & \text{if } a \notin S \\ S \setminus \{a\} & \text{if } a \in S \end{cases}.$$

Check that f_a is a bijection.

(3) Note that we are putting m distinguishable balls into n indistinguishable boxes. So, among the n boxes, there can be exactly k boxes, $k = 1, 2, \dots, n$ that are non-empty. So, using Remark 1.1.14, we get the number as $\sum_{k=1}^n S(m, k)$.

- (4) The direct count gives the total number of functions as n^m . The indirect count looks at the number of elements in $f(M)$. Suppose $|f(M)| = k$. Then $1 \leq k \leq n$ and we have $\binom{n}{k}$ subsets of N of size k . Also, for each subset K of N there are $k! S(m, k)$ onto functions $f : M \rightarrow K \subset N$. So, the total number of functions $f : M \rightarrow N$ is also given by $\sum_{k=1}^n \binom{n}{k} k! S(m, k)$. Therefore,

$$n^m = \sum_{k=1}^n \binom{n}{k} k! S(m, k) = \sum_{k=0}^n \binom{n}{k} k! S(m, k)$$

as $S(m, 0) = 0$ for $m > 0$. Also, the conventions $S(m, k) = 0$ for all $k > m$ and $\binom{n}{k} = 0$ for $k > n$ implies that we can replace the number n in the limit of the sum by m and obtain

$$n^m = \sum_{k=0}^m \binom{n}{k} k! S(m, k).$$

Let $S = \{a_1, a_2, \dots, a_n\}$ be a set consisting of n elements. Then for any $k \leq n$, any partition of S into k parts, either contains the set $\{a_n\}$ or the element a_n comes with some other element. In the first case, we need to partition the set $\{a_1, a_2, \dots, a_{n-1}\}$ into $k - 1$ parts, and in the later case, we need to partition the set $\{a_1, a_2, \dots, a_{n-1}\}$ into k parts with the element a_n appearing in any of the k parts. So, the answer is

$$S(n, k) = S(n - 1, k - 1) + kS(n - 1, k), \quad S(n, 1) = 1 \quad \text{and} \quad S(n, n) = 1.$$

- (5) Consider the set $\{1, 2, \dots, n\}$. The element n appears in the partition with some k elements of the above set for $k = 0, 1, \dots, n - 1$. These k elements can be chosen in $\binom{n-1}{k}$ ways. Also, for any such subset K of $\{1, 2, \dots, n\}$, and a partition P of the set $\{1, 2, \dots, n\} \setminus (K \cup \{n\})$, we get a partition of the set $\{1, 2, \dots, n\}$, consisting of $P, K \cup \{n\}$. The partition P can be chosen independent of K in $b(n - 1 - k)$ ways. Hence,

$$b(n) = \sum_{k=0}^{n-1} \binom{n-1}{k} b(n-1-k) = \sum_{k=0}^{n-1} \binom{n-1}{n-1-k} b(n-1-k) = \sum_{k=0}^{n-1} \binom{n-1}{k} b(k).$$

- (6) Think of the functions as follows: Out of a_1, a_2, \dots, a_m any k of them gives a map to $\{b_1, b_2, \dots, b_n\}$ and the remaining $m - k$ a_i 's is mapped to b_{n+1} .
- (7) Think of this as a problem about onto functions.
- (8) Observe that f is idempotent implies that f is an identity function on $f(N)$. So, let $|f(N)| = k$. Clearly $1 \leq k \leq n$. Let K be any subset of N of size k . There are $\binom{n}{k}$ subsets of N of size k . Then we need to consider all functions $f : N - K \rightarrow K$ so that $f(N) = K$. The total number of such functions is k^{n-k} . Hence, the required result.

- (9) $\binom{7}{3} = \binom{7}{4}$.
- (10) $\binom{n}{r}$ choices to place the A 's and so, the B 's get fixed.
- (11) $7!$ ways. Either look at all one-one functions $f : \{1, 2, \dots, 7\} \rightarrow \{b_1, b_2, b_3, b_4, g_1, g_2, g_3\}$. Or there are $\binom{7}{4}$ ways to choose the places for boys. They can be arranged in $4!$ ways and the remaining 3 places can be filled with girls in $3!$ ways. So, the number is $3! \cdot 4! \cdot \binom{7}{4}$.
- (12) $7!$ ways.
- (13) $n!$ ways. All one-one functions $f : \{1, 2, \dots, n\} \rightarrow \{p_1, p_2, \dots, p_n\}$.
- (14) $\binom{n}{r}$. Just take a subset of size r from the set $\{p_1, p_2, \dots, p_n\}$.
- (15) Let the n distinguishable objects be the elements of the set $S = \{p_1, p_2, \dots, p_n\}$. Now $\binom{n}{r}$ is the number of ways of choosing a subset of size r from S .
- (16) There are $\binom{20}{5}$ ways to give the toys to the first child, $\binom{15}{5}$ ways to give to the second child, $\binom{10}{5}$ ways to give to the third child and the rest to the fourth child. So, the answer is $\binom{20}{5} \cdot \binom{15}{5} \cdot \binom{10}{5} = \frac{20!}{5! 5! 5! 5!}$.
- (17) $\binom{18}{5} \cdot \binom{13}{6} = \frac{18!}{5! 6! 7!}$.
- (18) First observe that f is exactly k -injective if and only if $|f(X)| = k$. So, we need to pick a subset k of X , say S and we want to find the number of onto functions from X to S . Therefore, the answer is $\binom{n}{k} k! S(n, k)$.

Answers to Questions on Page 13

- (1) Suppose, we have i_1 letter consisting of a 's, i_2 letters consisting of b 's and so on till i_{26} letters consisting of z 's. Then we have to find number of solutions in non-negative integers to the equation $i_1 + i_2 + \dots + i_{26} = 4$. So, the answer is $\binom{26+4-1}{4} = \binom{29}{4}$.
- (2) As each box is supposed to be non-empty, let us put exactly one ball in each box. Then we are left with $m - (n) = m - n$ indistinguishable balls and they are supposed to be put into n boxes. So, using Remark 1.2.3, the answer is $\binom{m-n+n-1}{n-1} = \binom{m-1}{n-1}$.
- (3) *Method 1:* Put the consonants in any order (there are $21!$ ways) and choose 5 places from the 22 places that have been generated after putting the consonants. So, the answer is $21! \cdot 5! \cdot \binom{22}{5}$.

Method 2: Put the vowels in any order (there are $5!$ ways). Now you put any four consonants after the first 4 vowels. This helps us to get over the restriction that no two vowels are together. So, now we have to put the rest of the consonants ($17 = 21 - 4$) at the 6 places generated by putting the vowels. That is, solve in non-negative integers the equation $x_1 + x_2 + \cdots + x_6 = 17$. This gives the answer as $21! \cdot 5! \cdot \binom{17+6-1}{17} = 21! \cdot 5! \cdot \binom{22}{5}$.

(4) Put the vowels in any order (there are $5!$ ways). Now you put exactly two consonants between any two vowels (so, 8 consonants have been used). This helps us to get over the restriction. So, now we have to put the rest of the consonants ($13 = 21 - 8$) at the 6 places generated by putting the vowels. That is, solve in non-negative integers the equation $x_1 + x_2 + \cdots + x_6 = 13$. This gives the answer as $21! \cdot 5! \cdot \binom{13+6-1}{13} = 21! \cdot 5! \cdot \binom{18}{5}$.

(5) The reason is similar to Exercise 1.2.4.4. Hence the answer is $10! \cdot 7! \cdot \binom{11}{7}$.

(6) There are $6!$ ways to seat the six persons different from Ram and Shyam. Now we have $\binom{7}{2}$ places for Ram and Shyam. Also, $2!$ for arranging Ram and Shyam itself. So, the answer is $2! \cdot 6! \cdot \binom{7}{2}$.

(7) The reason is similar to Exercise 1.2.4.4. Hence the answer is $\frac{10!}{4! 2! 2!} \cdot \frac{8!}{4!} \cdot \binom{11}{8}$.

(8) There is only one way to arrange the vowels in alphabetical order. Now the consonants can be put anywhere among the 9 places created by the vowels. So, we need to solve for non-negative integers the equation $x_1 + x_2 + \cdots + x_9 = 10$. So, the answer is $\frac{10!}{4! 2! 2!} \cdot \binom{18}{8}$.

(9) Using Remark 1.2.3, the answer is $\binom{67+5-1}{67}$.

(10) Define $y_i = x_i - 1$ for $i = 1, 2, \dots, 5$. Replace x_i 's in the equation by the y_i 's. Then we need to solve for non-negative integers the equation $y_1 + y_2 + \cdots + y_5 = 62$. So, the answer is $\binom{62+5-1}{62}$.

(11) *Method 1:* Let $0 \leq k \leq 67$. Then we need to solve in non-negative integers the equation $x_1 + x_2 + \cdots + x_5 = k$. So, the answer is $\sum_{k=0}^{67} \binom{k+5-1}{k} = \binom{72}{5}$.

Method 2: The inequality can be made into an equation by solving in non-negative integers the equation $x_1 + x_2 + \cdots + x_5 + x_6 = 67$. So, the answer is $\binom{67+6-1}{67} = \binom{72}{5}$.

(12) As the order matters and the repetition is not allowed, we need to find the number of one-one functions $f : \{1, 2, \dots, r\} \rightarrow \{1, 2, \dots, n\}$. So, answer is $n(n-1) \cdots (n-r+1) = n_{(r)}$.

(13) As order matters and the repetition is allowed, we need to find the number of functions $f : \{1, 2, \dots, r\} \rightarrow \{1, 2, \dots, n\}$. So, the answer is n^r .

- (14) As repetition is not allowed and the order doesn't matter, we need to look at all subsets of size r from the set $\{1, 2, \dots, n\}$. So, the number is $\binom{n}{r}$.
- (15) Let the distinguishable objects be $1, 2, \dots, n$ and let x_i for $1 \leq i \leq n$ be the number of times the object i has appeared. Then we need to solve in non-negative integers the equation $x_1 + x_2 + \dots + x_n = r$. So, the answer is $\binom{r+n-1}{r}$.

Answers to Questions on Page 15

- (1) Note that there are 8 A 's, 2 B 's, 2 C 's, 2 D 's and 3 R 's. Let us just put the 8 A 's. Then B 's can appear at any of the 8 places after the first A has appeared. So, we need to solve in non-negative integers the equation $x_1 + x_2 + \dots + x_8 = 2$. This gives $\binom{2+8-1}{2}$ ways. The rest of the letters can be arranged among themselves in $\frac{7!}{2! 2! 3!}$ ways. Also, they can be put anywhere among the possible 11 places. So, we need to solve in non-negative integers the equation $x_1 + x_2 + \dots + x_{11} = 7$. This gives $\binom{7+11-1}{7}$ ways. So, the answer is $\frac{7!}{2! 2! 3!} \cdot \binom{2+8-1}{2} \cdot \binom{7+11-1}{7}$.
- (2) The first part remains the same as Exercise 2.B.1. For the other part, check that there are $\binom{2+2-1}{2}$ ways to get the first D preceding the first C . The D 's and C 's can be put anywhere among the possible 11 places. So, we need to solve in non-negative integers the equation $x_1 + x_2 + \dots + x_{11} = 4$. This gives $\binom{4+11-1}{4}$ ways. Now the R 's can be put anywhere among the possible 15 places. So, we need to solve in non-negative integers the equation $x_1 + x_2 + \dots + x_{15} = 3$. This gives $\binom{3+15-1}{3}$ ways. So, the answer is $\binom{2+8-1}{2} \cdot \binom{2+2-1}{2} \cdot \binom{4+11-1}{4} \cdot \binom{3+15-1}{3}$.
- (3) We have to find the number of solution in non-negative integers, the equation $x_1 + x_2 + \dots + x_5 = 60$ with the restriction that $x_1 + x_2 \leq 30$ and $x_3 \geq 10$. As Mohan gets at least 10, we get define $x_3 = y_3 + 10$. Also, for any r , $0 \leq r \leq 30$, we need to solve in non-negative integers the equation $x_1 + x_2 = r$. So, we need to solve in non-negative integers the equation $y_3 + x_4 + x_5 = 50 - r$. So, the answer is $\sum_{r=0}^{30} \binom{r+1}{1} \cdot \binom{50-r+3-1}{50-r} = \sum_{r=0}^{30} (r+1) \cdot \binom{52-r}{2}$.
- (4) We need to solve in non-negative integers, the equation $x_1 + x_2 + x_3 = 20$ with the restriction that $x_1 \leq 10$, $x_2 \leq 15$ and $x_3 \geq 15$. Observe that if $5 \leq x_1 \leq 10$, then we need to solve in non-negative integers the equation $x_2 + x_3 = 20 - x_1 \leq 15$. That is, in this case, there is no restriction on x_2 and x_3 and hence the solution for this part is $\sum_{r=5}^{10} \binom{20-r+1}{1}$. For the part $0 \leq x_1 \leq 4$, we need to look at the solution of $x_2 + x_3 = 20 - x_1$ with

the restriction on x_2 and x_3 still remaining. So, in this case, the number of solutions is $15 - (5 - r) + 1 = 11 + r$, $0 \leq r \leq 4$. Therefore, the total number of solutions is

$$\sum_{r=5}^{10} \binom{20-r+1}{1} + \sum_{r=0}^4 (11+r).$$

- (5) *Method 1:* First note that we can arrange the selected numbers in increasing order. Now, we need to have at least 3 numbers (the difference between any two of them is at least 4) between any two of the selected numbers. So, remove $18 = 3 \times 6$ numbers from the list. This leaves us with 32 numbers. So, the answer is $\binom{32}{7}$.

Method 2: Let the numbers be x_1, x_2, \dots, x_7 . Then $x_1 \geq 1, x_7 \leq 50$ and $x_{i+1} - x_i \geq 4$ for $i = 1, 2, \dots, 6$. Define $y_1 = x_1 - 1$ and for $i = 2, 3, \dots, 7$, define $y_{i+1} = x_{i+1} - x_i - 4$. Then $y_i \geq 0$ and $y_1 + y_2 + \dots + y_7 = x_7 - 25$. As $x_7 \leq 50$, we need to solve the inequality

$$y_1 + y_2 + \dots + y_7 \leq 25.$$

This is same as solving in non-negative integers the equation $y_1 + y_2 + \dots + y_7 + y_8 = 25$. So, the answer is $\binom{25+8-1}{25} = \binom{32}{7}$.

- (6) Total number of subsets of size 10 is $\binom{26}{10}$. Among these, there are $\binom{17}{10}$ that have no consecutive letters (To put 10 letters so that we don't have consecutive letters, we need to place one letter between any two letters. So 9 letters are used and we are left with 17 letters to choose from). So, the answer is $\binom{26}{10} - \binom{17}{10}$.

We can also think of the problem as follows: Consider the set $S = \{1, 2, 3, \dots, 26\}$. We want to find all the subsets of S of size 10 such that there is at least one pair of numbers m, n such that $m = n + 1$. So, let us look at all subsets of size 10 where such a condition is not valid. That is, if $\{x_1 \geq x_2 \geq \dots \geq x_{10}\}$ is a subset of size 10 then $x_{i+1} - x_i \geq 2$ for $i = 1, 2, \dots, 9$. This problem can now be solved using the idea in Method 2 of 5 to get to the problem "find the number of nonnegative integer solutions to the system

$$y_1 + y_2 + \dots + y_{10} \leq 7.$$

This leads to the answer $\binom{17}{7} = \binom{17}{10}$.

- (7) The number of elements in each set is m^n .
- (8) The number of elements in each set is $m_{(n)} = m(m-1) \dots (m-n+1)$.
- (9) The number of elements in each set is $\binom{m+n-1}{n}$.

- (10) There are n distinct objects. They can be arranged in $n!$ ways. For each such arrangement, there are $\binom{n+m-1}{n}$ ways of placing the objects into m distinct boxes. So, the total number is $n! \times \binom{n+m-1}{n} = m(m+1) \cdots (m+n-1) := m^{(n)}$.

Answers to Questions on Page 17

- (1) *Method 1:* At a round table, 7 women can be arranged in $6!$ ways. The men can be arranged among themselves in $5!$ ways and they can sit at any of the 7 places in $\binom{7}{5}$ ways. So, the answer is $6! \cdot 5! \cdot \binom{7}{5}$.

Method 2: At a round table, 5 men can be arranged in $4!$ ways. We can put 5 women after each man to get rid of the restriction. So, we are left with 2 women to be allowed to sit anywhere at the 5 places. So, we need to solve in non-negative integers the equation $x_1 + x_2 + \cdots + x_5 = 2$. The women in themselves can be arranged in $7!$ ways, so the answer is $\binom{2+5-1}{2} \cdot 4!7! = 6! \cdot 5! \cdot \binom{7}{5}$.

- (2) An argument similar to Exercise 3.1 gives the answer as $9! \cdot 7! \cdot \binom{10}{7}$.
- (3) Let Ram sit at position 1. The other 6 persons (excluding Shyam) can sit in $6!$ ways. Now, there are 5 positions for Shyam. So, the answer is $6! \cdot \binom{5}{1} = 6! \cdot 5$.
- (4) Either the first person is chosen or not. If the first person is chosen then we need to choose 5 more from the remaining $25 - 3 = 22$ with the restriction that no adjacent men are chosen. So, we need to choose 5 places from $18 = 22 - 4$ places. So, in this case the answer is $\binom{18}{5}$.

If the first person is not chosen, then we need to select 6 men from 24 men with no adjacent men being selected. That is, we need to choose 6 places from $24 - 5 = 19$ places. So, in this case the answer is $\binom{19}{6}$. So, overall the answer is

$$\binom{19}{6} + \binom{18}{5}.$$

- (5) Recall that the number of solutions in non-negative integers is in one-to-one correspondence with “the number of arrangements of $n-1$ ’s and $k+$ ’s.”

This is in one-to-one correspondence with “the number of arrangements of n H ’s and k U ’s.” And this gives the number of lattice paths from $(0,0)$ to (n,k) .

2 Mathematical Induction

Answers to Questions on Page 28

- (1) The result is true for $n = 1$. Assume the result for $n = k$. Then for $n = k + 1$, we have

$$\begin{aligned} 1 + 2 + \cdots + k + (k + 1) &= \frac{k(k + 1)}{2} + (k + 1) && \text{Use induction} \\ &= \frac{(k + 1)(k + 2)}{2}. \end{aligned}$$

So, the result is true for $n = k + 1$. Hence the result is true for all $n \in \mathbb{N}$ by the use of principle of mathematical induction.

- (2) The result is true for $n = 1$. Assume the result for $n = k$. Then for $n = k + 1$, we have

$$\begin{aligned} 1 + 3 + \cdots + (2k - 1) + (2k + 1) &= k^2 + (2k + 1) && \text{Use induction} \\ &= (k + 1)^2. \end{aligned}$$

So, the result is true for $n = k + 1$. Hence the result is true for all $n \in \mathbb{N}$ by the use of principle of mathematical induction.

- (3) The result is true for $n = 1$. Assume the result for $n = k$. Then for $n = k + 1$, we have

$$\begin{aligned} 1^2 + 2^2 + \cdots + k^2 + (k + 1)^2 &= \frac{k(k + 1)(2k + 1)}{6} + (k + 1)^2 && \text{Use induction} \\ &= \frac{(k + 1)(k + 2)(2k + 3)}{6}. \end{aligned}$$

So, the result is true for $n = k + 1$. Hence the result is true for all $n \in \mathbb{N}$ by the use of principle of mathematical induction.

- (4) Note that $(n + 1)^4 - n^4 = 4n^3 + 6n^2 + 4n + 1$. So,

$$\begin{aligned} (n + 1)^4 - 1^4 &= ((n + 1)^4 - n^4) + (n^4 - (n - 1)^4) + \cdots + (3^4 - 2^4) + (2^4 - 1^4) \\ &= 4 \sum_{k=1}^n k^3 + 6 \sum_{k=1}^n k^2 + 4 \sum_{k=1}^n k + n \\ &= 4 \sum_{k=1}^n k^3 + n(n + 1)(2n + 1) + 2n(n + 1) + n. \end{aligned}$$

Therefore,

$$\sum_{k=1}^n k^3 = \frac{1}{4} ((n + 1)^4 - 1 - (n(n + 1)(2n + 1) + 2n(n + 1) + n)) = \left(\frac{n(n + 1)}{2} \right)^2.$$

Now, use $(n + 1)^5 - n^5 = 5n^4 + 10n^3 + 10n^2 + 5n + 1$ and the above method to get your answer.

- (6) The result is true for $n = 1$. Assume the result for $n = k$. To prove the result for $n = k + 1$. Let $S = \{a_1, a_2, \dots, a_k, a_{k+1}\}$. Now note that by induction hypothesis there are exactly 2^k subsets of the set $\{a_1, a_2, \dots, a_k\}$. In all these 2^k subsets, we can put a_{k+1} to get 2^k distinct subsets of S . So, the total number of distinct subsets is

$$2^k + 2^k = 2^{k+1}.$$

So, the result is true for $n = k + 1$. Hence the result is true for all $n \in \mathbb{N}$ by the use of principle of mathematical induction.

3 Pigeonhole Principle

Answers to Questions on Page 33

- (1) Let $n = 2m + 1$. Then there are m even numbers and $m + 1$ odd numbers. Therefore, in $P(p)$ there exists at least one k such that k and $p(k)$ have the same parity.
- (2) Let x_i denote the number of friends of the i th person. Clearly $1 \leq x_i \leq n - 1$ and there are n numbers x_i 's. So, at least two of them are equal.
- (3) Partition the equilateral triangle of length 1 unit into 4 congruent equilateral triangles of length .5 units.
- (4) Out of five points, there will be three points which has the same parity for the first component. Out of this three, there will be at least two which has the same parity for the second component.
- (5) Let $g(x) = f(x) - 4$. Then $g(a) = g(b) = g(c) = 0$. That is, $x - a, x - b$ and $x - c$ divide $g(x)$. Thus $g(x) = (x - a)(x - b)(x - c)h(x)$ for some polynomial $h(x)$ that has integral coefficients. Now suppose that there is an integer m such that $f(m) = 5$. Then $1 = 5 - 4 = f(m) - 4 = g(m) = (m - a)(m - b)(m - c)h(m)$ with $m - a, m - b, m - c, h(m) \in \mathbb{Z}$. That is, all the four integers are allowed to be either 1 or -1 . This is not possible as a, b and c are distinct integers.
- (6) Consider the set $S = \{3^\ell : \ell \in \mathbb{N}\}$. The set S has infinite number of elements and all of them give remainder between 0 and 2004, when divided by 2005. So, there are at least two numbers, say 3^i and 3^j with $i < j$ such that they leave the same remainder when divided by 2005. That is, 2005 divides $3^j - 3^i$.
- (7) Note that this question is same as asking the following: there is a power of 3 which when divided by 10000 leaves the remainder 1. Or equivalently, 10000 divides $3^\ell - 1$ for some

$\ell \in \mathbb{N}$. Proceed as in the above problem to get 10000 divides $3^j - 3^i$. But $\gcd(10000, 3) = 1$ and hence 10000 divides $3^{j-i} - 1$.

- (9) Make groups of two chairs that are allowed.
- (10) If one of the numbers is a multiple of n , we are done. So, let us assume that none of the elements is a multiple of n . Consider the set $S = \{x_1, x_1 + x_2, \dots, x_1 + x_2 + \dots + x_n\}$. The set S has n elements and they leave a remainder between 1 and $n - 1$ when divided by n . So, two of them give the same remainder when divided by n . So, the result follows.
- (11) *Method 1:* Note that the remainders $0, 1, 2, \dots, 2004$ (when a number is divided by 2005) can be grouped into 1003 sets as follows:

$$\{0\}, \{1, 2004\}, \{2, 2003\}, \dots, \{i, 2005 - i\}, \dots, \{1002, 1003\}.$$

As we have 1004 numbers and 1003 sets, two of the numbers, say x_i, x_j , must lie in the same set. If the numbers are equivalent modulo 200, then $x_i x_j$ is divisible by 2005, else $x_i + x_j$ is divisible by 2005.

Method 2: Let the 1004 integers be $x_1, x_2, \dots, x_{1004}$. Now consider the set $S = \{x_1 \pm x_i : i = 2, 3, \dots, 1004\}$. This set has 2006 numbers and there are only 2005 choices for the remainder.

- (12) Let x_i denote the number of pizzas taken till the i th day. Then $1 \leq x_1 < x_2 < \dots < x_{15} = 25$ (strict inequality as at least one pizza is being taken each day). Also, $x_1 + 4 < x_2 + 4 < \dots < x_{15} + 4 = 29$. So, we have 30 numbers and they lie between 1 and 29. Hence, at least two of them are equal. So, there exist i and j , ($i > j$) such that $x_i = x_j + 4$. That is, $x_i - x_j = 4$.
- (13) The argument is similar to the above question.
- (14) There are at least two numbers with the same parity.
- (15) Let $A = \{x_1, x_2, \dots, x_9\}$. Then observe that 1 is the smallest possible sum and $58 + \dots + 65 = 492$ is the largest possible sum for any proper subset of A . Also, we have $512 = 2^9$ possible subsets of A . But then $512 > 492$. So, the pigeonhole principle implies that there will be two subsets of A which will give the same sum. These two subsets need not be disjoint. Remove the common ones to get the result.
- (16) The argument is similar to the above question.
- (17) The worst case that we can think of is choosing all the even numbers. This will just give us n numbers. So, we are forced to choose an odd number which will give the desired result.

- (18) If the average is m , then at least one of them has to be larger than or equal to m . The reason being “if all the numbers is strictly less than m , then the average will also be strictly less than n .”
- (19) Number the sectors of both the discs as $1, 2, \dots, 2n$. Now fix disc A and put disc B above disc A such that the sector numbered 1 of both the discs are one above the other. The idea is to rotate disc B , $2n$ times, by an angle of $\frac{\pi}{n}$ and get back to the original position. For $1 \leq \ell \leq 2n$, let a_ℓ denote the number of matching sectors when disc B is rotated by an angle $\frac{\ell\pi}{n}$. Then observe that after $2n$ rotations, each sector of B has covered either all the n yellow sectors of A or all the n green sectors of A exactly once. So, each sector of B gives rise to exactly n matchings after $2n$ rotations. Hence $a_1 + a_2 + \dots + a_{2n} = 2n^2$. Thus $\frac{a_1 + a_2 + \dots + a_{2n}}{2n} = n$. Thus the result follows.
- (20) The argument is similar to the answer of Exercise 6.
- (21) Each real number can be associated with $\tan(\theta)$ for some $\theta \in (-\pi, \pi)$. Also, we can divide this interval into 6 equal intervals and $\tan(A - B) = \frac{\tan(A) - \tan(B)}{1 + \tan(A)\tan(B)}$.
- (22) Let the given sequence be $T = \{x_1, x_2, \dots, x_n\}$. If one of the elements $S = \{x_1, x_1 + x_2, \dots, x_1 + x_2 + \dots + x_n\}$ is a multiple of n , we are done. So, let us assume that none of the elements of S are a multiple of n . So, the remainder of these n numbers lies between 1 and $n - 1$. So, two of them are equal and we get the required result.
- (23a) If the whole plane is coloured with only one colour, we are done. So, assume that both the colours have been used. Pick a point at random, which is coloured yellow. Now, take a circle of radius 1 unit with the chosen yellow point as centre. If there is one yellow point on the circle, we are done. If all the colours on the circle are green then there are two points on the circle that are at a distance of 1 unit.
- (23b) We know that there are two points, say A and B in the plane that have the same colour. Use point A as the center and draw a circle of unit radius. Use the B to make a hexagon of unit length. If the vertex adjacent to B also has the same colour, we are done. Else, the two adjacent vertices need to have a different colour. If the vertex opposite the vertex B also has the same colour as the two vertices that are adjacent to B , we are done. Else this vertex is coloured the same as the vertex B and the other vertices are all coloured differently. Now extend the segments to get an equilateral triangle of 2 units to complete the result. (For details, See Figure 5.1.)
- (23c) Consider a horizontal line segment and choose nine points at random. Then there are 5 points with the same colour, say red. Draw three lines parallel to this line and draw

the vertical lines passing through the red vertices. Use the two colours to colour the new vertices that are 10 in number to get the result. If two vertices on the second horizontal line also have the colour red, we are done. So, exactly one vertex on the second horizontal line has colour red. So, see what can be done for the third horizontal line. (For details, See Figure 5.1.)

- (24) Pick a person. He has either 3 mutual friends or 3 mutual strangers. Now look at these four people and get the answer.
- (25) Without loss of generality, assume that $m, n \in \mathbb{N}$ and $n > m$. Consider the numbers

$$m, 2m, 3m, \dots, (n-1)m.$$

As m and n are coprime, check that n does not divide jm for $1 \leq j \leq n-1$. Also, if there does not exist j , $1 \leq j \leq n-1$ such that $jm \equiv 1 \pmod{n}$, then the above $n-1$ numbers when divided by n will have to lie in the $n-2$ boxes corresponding to the possible remainders $2, 3, \dots, n-1$. But then by pigeonhole principle, two of the numbers will have the same remainder. This implies that n divides $jm - im = (j-i)m$ for some $1 \leq i < j \leq n-1$. This is a contradiction as m and n are coprime and $1 < j-i < n$. Hence the result holds.

- (26) Without loss of generality, assume that $0 \leq a, b < m$. Now consider the numbers

$$a, a+m, a+2m, \dots, a+(n-1)m.$$

Suppose there does not exist j , $0 \leq j \leq n-1$ such that $a+jm \equiv b \pmod{n}$. Then the above n numbers when divided by n will have to lie in the $n-1$ boxes corresponding to the possible remainders $0, 1, \dots, b-1, b+1, \dots, n-1$. But then by pigeonhole principle, two of the numbers will have the same remainder. This implies that n divides $jm - im = (j-i)m$ for some $1 \leq i < j \leq n-1$. This is a contradiction as m and n are coprime and $1 < j-i < n$. Hence the result holds.

- (27) Yes. Consider the numbers

$$7, 77, 777, \dots$$

These numbers when divided by 2007 leave the remainders $0, 1, 2, \dots, 2006$. So, there exists two numbers that leave the same remainder. That is, 2007 divides

$$\underbrace{77 \dots 7}_{j \text{ times}} - \underbrace{77 \dots 7}_{i \text{ times}} = \underbrace{77 \dots 7}_{j-i \text{ times}} \underbrace{00 \dots 0}_{i \text{ times}}$$

for some $j > i$. But 2007 is coprime to 10^t for any positive integer t . So, the result follows.

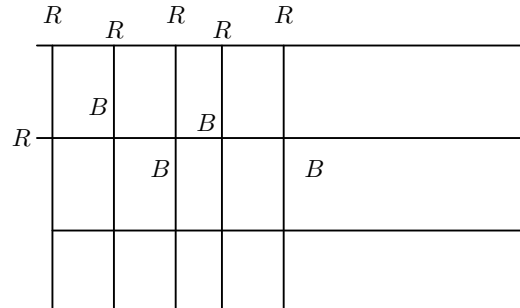
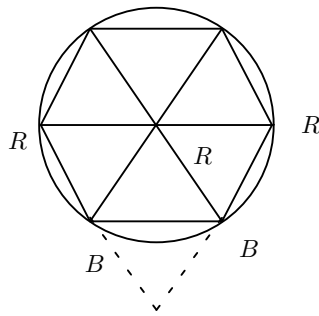

R, B Figure 5.1: Equilateral Triangel and Rectangle

4 Inclusion and Exclusion

Answers to Questions on Page 37

- (1) Let U denote the set of all possible ways in which the students collect the umbrellas. Then $|U| = n!$. For $1 \leq i \leq n$, let A_i denote that subset of U for which the i^{th} student doesn't collect his/her umbrella. Then we are interested in calculating $|A_1 \cap A_2 \cap \dots \cap A_n|$. By the principle of inclusion-exclusion, we need to calculate

$$\frac{1}{|U|} (|U| - S_1 + S_2 - S_3 + \dots).$$

Check that for $1 \leq i < j < k < \dots \leq n$, $|A_i| = (n-1)!$, $|A_i \cap A_j| = (n-2)!$, $|A_i \cap A_j \cap A_k| = (n-3)!$ and so on. Hence, the required answer is

$$\begin{aligned} \frac{1}{n!} \left(n! - n \cdot (n-1)! + \binom{n}{2} (n-2)! - \binom{n}{3} (n-3)! + \dots \right) &= 1 - \frac{1}{1!} + \frac{1}{2!} - \frac{1}{3!} + \dots \\ &\longrightarrow \frac{1}{e} \text{ as } n \longrightarrow \infty. \end{aligned}$$

- (2) Let U denote the total number of placements of 30 balls into 4 distinguishable boxes and let A_i denote that subset of U for which the i^{th} box gets more than 10 balls. We need to count the number of ways in which, none of the A_i 's occur. Note the following:

$$|U| = \binom{30+4-1}{4}, \quad |A_i| = \binom{19+4-1}{4}, \quad \text{and} \quad |A_i \cap A_j| = \binom{8+4-1}{4}.$$

So, the required answer is

$$\binom{30+4-1}{4} - \binom{4}{1} \binom{19+4-1}{4} + \binom{4}{2} \binom{8+4-1}{4}.$$

- (3) Let U denote the total number of placements of 30 balls into 10 distinguishable boxes and let A_i denote that subset of U for which the i^{th} box is empty. We need to determine

$|A_1 \cup A_2 \cdots \cup A_{10}|$. Note the following:

$$|U| = 10^{30}, \quad |A_i| = 9^{30}, \quad |A_i \cap A_j| = 8^{30}, \quad |A_i \cap A_j \cap A_k| = 7^{30}, \quad \text{and so on.}$$

So, the required answer is

$$\binom{10}{1} 9^{30} - \binom{10}{2} 8^{30} + \binom{10}{3} 7^{30} - \cdots = \sum_{k=1}^9 (-1)^{k-1} \binom{10}{k} (10-k)^{30}.$$

(4) Observe that this problem is a generalisation of Problem 3. So, the answer is

$$\sum_{k=1}^n (-1)^{k-1} \binom{n}{k} (n-k)^m.$$

(5) Observe that this problem is the complement of Problem 4. That is, if we let U denote the total number of function $f : M \rightarrow N$ and let A_i denote that subset of U for which the i^{th} element of N is not in the image, then we are interested in the calculation of “the number of functions that belongs to none of the A_i ’s”. So, the required answer is

$$\sum_{k=0}^n (-1)^k \binom{n}{k} (n-k)^m.$$

(6) Observe that this problem is the same as Problem 4. Hence, the required answer is

$$\sum_{k=0}^n (-1)^k \binom{n}{k} (n-k)^r = n! S(r, n).$$

(7) Observe that this problem is same as number of onto function from the set of books, 40 in number, to the set of students, 25 in number. That is, this is same as Problem 5 with $|M| = 40$ and $|N| = 25$. So, the answer is

$$\sum_{k=0}^{25} (-1)^k \binom{25}{k} (25-k)^{40}.$$

(8) Let U denote the $10!$ ways of arranging the 10 given numbers and let A_i denote the arrangement in which the number $i+1$ appears immediately after i , for $i = 1, 2, \dots, 9$. Then we are interested in the calculation of “none of the A_i ’s appears”. So, the answer is

$$10! - \binom{9}{1} (10-1)! + \binom{9}{2} (10-2)! + \cdots = \sum_{i=0}^9 \binom{9}{i} (10-i)!.$$

- (9) Let U be the set of all 15 term sequences in the digits $0, 1, \dots, 9$ and for $0 \leq i \leq 9$ let A_i denote the sequences that do not contain the digit i . Then $|U| = 10^{15}$, $|A_i| = 9^{15}$, $|A_i \cap A_j| = 8^{15}$ and so on. So, the answer is

$$|A_0 \cap A_1 \cap \dots \cap A_9| = \sum_{i=1}^9 (-1)^{k-1} \binom{10}{i} (10-i)^{15}.$$

Answers to Questions on Page 65

(1) 3.

(2) The cycle index polynomial is $\frac{1}{12} (z_1^6 + 8z_3^2 + 3z_1^2z_2^2)$. So, the required answer is 12.(3) The cycle index polynomial is $\frac{1}{12} (z_1^4 + 8z_1^2z_3 + 3z_2^2)$. So, the required answer is 15.(4) $\frac{1}{24} (n^8 + 17n^4 + 6n^2)$.(5) The cycle index polynomial is $\frac{1}{12} (z_1^6 + 2z_6 + 2z_3^2 + 4z_2^3 + 3z_1^2z_2^2)$. So, the required answer is 3.

(6) The cycle index polynomial is

$$\frac{1}{48} (z_1^7 + 7z_1^5z_2 + 8z_1^4z_3 + 6z_1^3z_4 + 9z_1^3z_2^2 + 8z_1^2z_2z_3 + 6z_1z_2z_4 + 3z_1z_2^3).$$

So, the required answer is 30.

Answers to Questions on Page 82

(1) Let n be a non-negative integer. Prove the Reed Dawson's identity

$$\sum_{k \geq 0} \binom{n}{k} \binom{2k}{k} (-1)^k 2^{-k} = \begin{cases} \binom{n}{n/2}, & \text{if } n \text{ is even;} \\ 0, & \text{otherwise.} \end{cases}$$

(2) Let $m, n \in \mathbb{N}$. Then prove that $\sum_{k \geq 0} \binom{n+k}{m+2k} \binom{2k}{k} \frac{(-1)^k}{k+1} = \binom{n-1}{m-1}$.(3) Let n be a non-negative integer. Prove that $\sum_{k \geq 0} \binom{n+k}{2k} 2^{n-k} = \frac{2^{2n+1} + 1}{3}$.(4) Let $m, n \in \mathbb{N}$. Determine whether or not the following identities are correct.

$$(4a) \sum_{k \geq 0} \binom{m}{k} \cdot \binom{n+k}{m} = \sum_{k \geq 0} \binom{m}{k} \cdot \binom{n}{k} 2^k.$$

$$(4b) \sum_{k=0}^n (-1)^k \binom{m+1}{k} \binom{m+n-k}{m} = \begin{cases} 1, & \text{if } n = 0, \\ 0, & \text{if } n > 0. \end{cases}$$

(4c) Correct.

Method 1: Both of them are coefficient of x^n in the expansion of $\frac{(-x)^{m+1}}{1-x}$. It follows

$$\text{by calculating } \sum_{n \geq m+1} \left(\sum_{k=m+1}^n (-1)^k \binom{n}{k} \binom{k-1}{m} \right) x^n = \sum_{k \geq m+1} (-1)^k \binom{k-1}{m} \sum_{n \geq k} \binom{n}{k} x^n =$$

$$\frac{1}{1-x} \sum_{t \geq 0} \binom{m+t}{m} \left(-\frac{x}{1-x} \right)^{t+m+1} = \frac{(-x)^{m+1}}{1-x}.$$

$$\text{Method 2: LHS} = \int_0^1 \frac{1 - (1-x)^n}{x} dx = \int_0^1 \frac{1-x^n}{1-x} dx = \text{RHS}.$$

$$\sum_{k=m+1}^n (-1)^k \binom{n}{k} \binom{k-1}{m} = (-1)^{m+1}.$$

(5) Correct.

Method 1: Both of them are coefficient of x^n in the expansion of $\frac{\log(1-x)}{1-x}$.

$$\text{Method 2: LHS} = \int_0^1 \frac{1 - (1-x)^n}{x} dx = \int_0^1 \frac{1-x^n}{1-x} dx = \text{RHS}.$$

Bibliography

- [1] J. Cofman, “Catalan Numbers for the Classroom?”, *Elem. Math.*, 52 (1997), 108 - 117.
- [2] D. I. A. Cohen, *Basic Techniques of Combinatorial Theory*, John Wiley and Sons, New York, 1978.
- [3] William Dunham, *Euler, The Master of Us All*, Published and Distributed by The Mathematical Association of America, 1999.
- [4] G. E. Martin, *Counting: The Art of Enumerative Combinatorics*, Undergraduate Texts in Mathematics, Springer, 2001.
- [5] R. Merris, *Combinatorics*, 2th edition, Wiley-Interscience, 2003.
- [6] J. Riordan, *Introduction to Combinatorial Analysis*, John Wiley and Sons, New York, 1958.
- [7] R. P. Stanley, *Enumerative Combinatorics, vol. 2*, Cambridge University Press, 1999.
- [8] H. S. Wilf, *Generatingfunctionology*, Academic Press, 1990.