

Syllabus

Sub Code	:	10IT35	IA Marks	:	25
Hrs/ Week	:	04	Exam Hours	:	03
Total Hrs.	:	52	Exam Marks	:	100

PART – A

UNIT – 1:

Introduction

- (a) **Measurement Errors:** Gross errors and systematic errors, Absolute and relative errors, Accuracy, Precision, Resolution and Significant figures. (Text 2: 2.1 to 2.3)
- (b) **Voltmeters and Multimeters** Introduction, Multirange voltmeter, Extending voltmeter ranges, Loading, AC voltmeter using Rectifiers – Half wave and full wave, Peak responding and True RMS voltmeters. (Text 1: 4.1, 4.4 to 4.6, 4.12 to 4.14, 4.17, 4.18)

07 Hours

UNIT – 2:

Digital Instruments

Digital Voltmeters – Introduction, DVM's based on $V - T$, $V - F$ and Successive approximation principles, Resolution and sensitivity, General specifications, Digital Multi-meters, Digital frequency meters, Digital measurement of time (Text 1: 5.1 to 5.6; 5.9 and 5.10; 6.1 to 6.4)

07 Hours

UNIT – 3:

Oscilloscopes

Introduction, Basic principles, CRT features, Block diagram and working of each block, Typical CRT connections, Dual beam and dual trace CROs, Electronic switch (Text 1: 7.1 to 7.9, 7.12, 7.14 to 7.16)

06 Hours

UNIT – 4:

Special Oscilloscopes

Delayed time-base oscilloscopes, Analog storage, Sampling and Digital storage oscilloscopes (Text 2: 10.1 to 10.4)

06 Hours

PART – B**UNIT – 5:****Signal Generators**

Introduction, Fixed and variable AF oscillator, Standard signal generator, Laboratory type signal generator, AF sine and Square wave generator, Function generator, Square and Pulse generator, Sweep frequency generator, Frequency synthesizer (Text 1: 8.1 to 8.9 &Text 2: 11.5, 11.6)

06 Hours**UNIT – 6:****Measurement of resistance, inductance and capacitance**

Whetstone's bridge, Kelvin Bridge; AC bridges, Capacitance Comparison Bridge, Maxwell's bridge, Wein's bridge, Wagner's earth connection (Text 1: 11.1 to 11.3, 11.8, 11.9, 11.11, 11.14 and 11.15)

07 Hours**UNIT – 7:****Transducers - I**

Introduction, Electrical transducers, Selecting a transducer, Resistive transducer, Resistive position transducer, Strain gauges, Resistance thermometer, Thermistor, Inductive transducer, Differential output transducers and LVDT, (Text 1: 13.1 to 13.11)

07 Hours**UNIT – 8:****Miscellaneous Topics**

- (a) **Transducers - II** –Piezoelectric transducer, photoelectric transducer, Photovoltaic transducer, Semiconductor photo devices, Temperature transducers-RTD, Thermocouple (Text 1: 13.15 to 13.20)
- (b) **Display devices:** Digital display system, classification of display, Display devices, LEDs, LCD displays (Text 1: 2.7 to 2.11)
- (c) Bolometer and RF power measurement using Bolometer (Text 1: 20.1 to 20.9)
- (d) Introduction to Signal conditioning (Text 1: 14.1)

06 Hours**TEXT BOOKS:**

1. “**Electronic Instrumentation**”, H. S. Kalsi, TMH, 2004
2. “**Electronic Instrumentation and Measurements**”, David A Bell, PHI / Pearson Education, 2006.

REFERENCE BOOKS:

1. “**Principles of measurement systems**”, John P. Beatly, 3rd Edition, Pearson Education, 2000
2. “**Modern electronic instrumentation and measuring techniques**”, Cooper D & A D Helfrick, PHI, 1998.

3. “**Electronic and Electrical measurements and Instrumentation**”, J. B. Gupta, S. K. Kataria & Sons, Delhi

4. **Electronics & electrical measurements**, A K Sawhney, , Dhanpat Rai & sons, 9th edition.

Question Paper Pattern: Student should answer FIVE full questions out of 8 questions to be set each carrying 20 marks, **selecting at least TWO questions from each part**

Coverage in the Texts:

UNIT – 1: (a) Text 2: 2.1 to 2.3; (b) Text 1: 4.1, 4.4 to 4.6, 4.12 to 4.14, 4.17, 4.18

UNIT – 2: Text 1:5.1 to 5.6; 5.9 and 5.10; 6.1 to 6.4

UNIT – 3: Text 1: 7.1 to 7.9, 7.12, 7.14 to 7.16

UNIT – 4: Text 2: 10.1 to 10.5

UNIT – 5: Text 1: 8.1 to 8.9 and Text 2: 11.5, 11.6

UNIT – 6: Text 1: 11.1 to 11.3, 11.8, 11.9, 11.11, 11.14 and 11.15

UNIT – 7: Text 1: 13.1 to 13.11

UNIT – 8: (a) Text 1: 13.15 to 13.20.2 (b) Text 1: 2.7 to 2.12 (c) Text 1: 20.1 to 20.9, (d) Text 1:14.1

INDEX SHEET

SL.NO	TOPIC	PAGE NO.
	<u>PART – A</u>	
UNIT – I: Introduction		12 to 31
	a. Measurement errors:	
	Gross Errors and Systematic Errors	
	Absolute Errors and Relative Errors	
	Accuracy	
	Precision	
	Resolution	
	Significant Figures	
	b. Voltmeters and Multimeters:	
	Introduction	
	Multirange voltmeter	
	Extending voltmeter ranges	
	Loading	
	AC voltmeter using Rectifiers (half wave and full wave)	
	Peak Responding	
	True RMS voltmeters	
UNIT - 2: Digital Instruments		32 to 52
	Digital voltmeter – introduction	
	DVM's based on V-T	
	V-F and successive approximation principles	

	Resolution and sensitivity	
	General specifications	
	Digital Multimeters	
	Digital frequency meters	
	Digital Measurement of Time	
UNIT - 3: Oscilloscopes		53 to 61
	Introduction	
	Basic Principles	
	CRT features	
	Block Diagram and working of each block	
	Typical CRT connections	
	Dual Beam and Dual Trace CROs	
	Electronic Switch	
UNIT - 4: Special Oscilloscopes		62 to 69
	Delayed time – base oscilloscopes	
	Analog storage	
	Sampling	
	Digital storage oscilloscope	
<u>PART – B</u>		
UNIT - 5: Signal Generators		70 to 79
	Introduction	
	Fixed and Variable AF oscillator	
	Standard Signal Generator	
	Laboratory type signal generator	
	AF sine and square wave generator	
	Function Generator	
	Square and Pulse generator	
	Sweep generator	

	Frequency synthesizer	
UNIT - 6: Measurement of resistance, inductance and capacitance		80 to 84
	Wheatstone's Bridge	
	Kelvin Bridge	
	AC bridges	
	Capacitance Comparison bridge	
	Maxwell's bridge	
	Wein's Bridge	
	Wagner's earth connection	
UNIT - 7: Transducers – I		85 to 97
	Introduction	
	Electrical transducers	
	Selecting a transducer	
	Resistive position transducer	
	Strain gauges	
	Resistance thermometer	
	Thermistor	
	Inductive transducer	
	Differential o/p transducers	
	LVDT	
UNIT - 8: Miscellaneous Topics		98 to 120
	a. Transducers – II	
	Piezoelectric transducers	
	Photoelectric transducer	
	Photovoltaic transducer	
	Semiconductor photo devices	
	Temperature transducer – RTD	
	Thermocouple	
	b. Display devices.	

	Digital display system	
	Classification of display	
	Display devices	
	LEDs displays	
	LCD displays	
	c. Bolometer and RF power measurement using Bolometer	
	d. Introduction to signal processing.	

Unit:I

Hrs: 07

Syllabus:

Introduction

(a) **Measurement Errors:** Gross errors and systematic errors, Absolute and relative errors, Accuracy, Precision, Resolution and Significant figures. (Text 2: 2.1 to 2.3)

(b) **Voltmeters and Multimeters** Introduction, Multirange voltmeter, Extending voltmeter ranges, Loading, AC voltmeter using Rectifiers – Half wave and full wave, Peak responding and True RMS voltmeters. (Text 1: 4.1, 4.4 to 4.6, 4.12 to 4.14, 4.17, 4.18)

Recommended readings:

1. “Electronic Instrumentation”, H. S. Kalsi, TMH, 2004
2. “Electronic Instrumentation and Measurements”, David A Bell, PHI / Pearson Education, 2006.

Introduction

Measurement Errors:

Introduction:

The measurement of any quantity plays very important role not only in science but in all branches of engineering, medicine and in almost all the human day to day activities.

The technology of measurement is the base of advancement of science. The role of science and engineering is to discover the new phenomena, new relationships, the laws of nature and to apply these discoveries to human as well as other scientific needs. The science and engineering is also responsible for the design of new equipments. The operation, control and the maintenance of such equipments and the processes is also one of the important functions of the science and engineering branches. All these activities are based on the proper measurement and recording of physical, chemical, mechanical, optical and many other types of parameters.

The measurement of a given parameter or quantity is the act or result of a quantitative comparison between a predefined standard and an unknown quantity to be measured. The major problem with any measuring instrument is the error. Hence, it is necessary to select the appropriate measuring instrument and measurement procedure which minimises the error. The measuring instrument should not affect the quantity to be measured.

An electronic instrument is the one which is based on electronic or electrical principles for its measurement function. The measurement of any electronic or electrical quantity or variable is termed as an electronic measurement.

Advantages of Electronic Measurement

The advantages of an electronic measurement are

1. Most of the quantities can be converted by transducers into the electrical or electronic signals.
2. An electrical or electronic signal can be amplified, filtered, multiplexed, sampled and measured.
3. The measurement can easily be obtained in or converted into digital form for automatic analysis and recording.
4. The measured signals can be transmitted over long distances with the help of cables or radio links, without any loss of information.
5. Many measurements can be carried either simultaneously or in rapid succession.
6. Electronic circuits can detect and amplify very weak signals and can measure the events of very short duration as well.

7. Electronic measurement makes possible to build analog and digital signals. The digital signals are very much required in computers. The modern development in science and technology are totally based on computers.
8. Higher sensitivity, low power consumption and a higher degree of reliability are the important features of electronic instruments and measurements. But, for any measurement, a well defined set of standards and calibration units is essential. This chapter provides an introduction to different types of errors in measurement, the characteristics of an instrument and different calibration standards.

Functional elements of an instruments:

Any instrument or a measuring system can be described in general with the help of a block diagram. While describing the general form of a measuring system, it is not necessary to go into the details of the physical aspects of a specific instrument. The block diagram indicates the necessary elements and their functions in a general measuring system. The entire operation of an instrument can be studied interms of these functional elements. The Fig. 1.1 shows the block diagram showing the functional elements of an instrument.

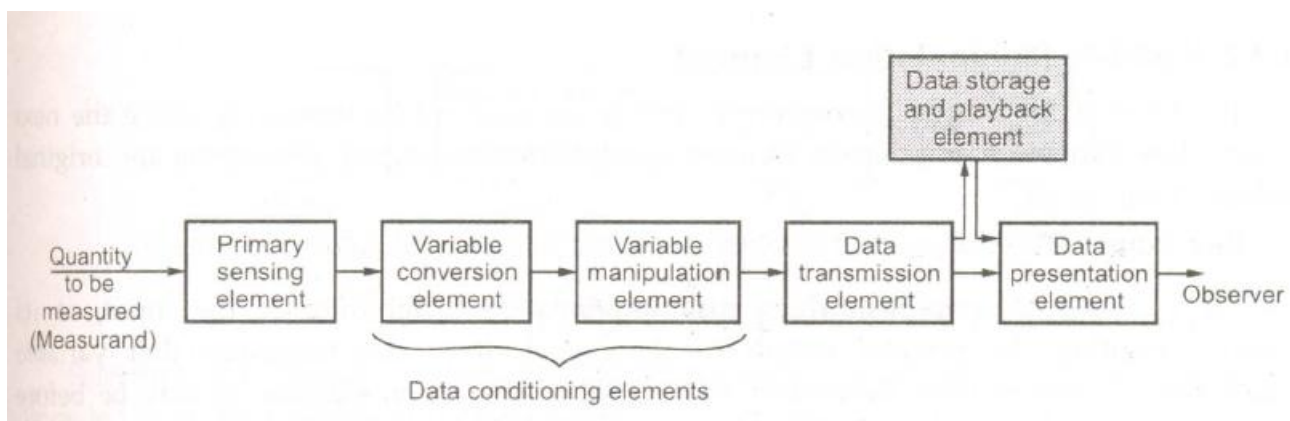

Calibration:

Calibration is the process of making an adjustment or marking a scale so that the readings of an instrument agree with the accepted and the certified standard.

The calibration offers a guarantee to the device or instrument that it is operating with required accuracy, under the stipulated environmental conditions. It creates the confidence of using

the properly calibrated instrument, in user's mind. The periodic calibration of an instrument is very much necessary.

The calibration characteristics can be determined by applying known values of quantities to be measured and recording the corresponding output of the instrument. Such output values are then compared with the input, to determine the error. Such a record obtained from calibration is called calibration record. It is generally recorded in the tabular form. If it is represented in the graphical form, it is called calibration curve. Such a calibration record or calibration curve is useful to obtain the performance characteristics of an instrument. The performance of the instrument is not guaranteed by the calibration. It only indicates whether the performance of the instrument is meeting the accuracy and range specification or not. If the device has been repaired, aged, adjusted or modified, then recalibration is carried out.

Static characteristics:

As mentioned earlier, the static characteristics are defined for the instruments which measure the quantities which do not vary with time. The various static characteristics are accuracy, precision, resolution, error, sensitivity, threshold, reproducibility, zero drift, stability and linearity.

Accuracy:

It is the degree of closeness with which the instrument reading approaches the true value of the quantity to be measured. It denotes the extent to which we approach the actual value of the quantity. It indicates the ability of instrument to indicate the true value of the quantity. The accuracy can be expressed in the following ways.

1) Accuracy as 'Percentage of Full Scale Reading' : In case of instruments having uniform scale, the accuracy can be expressed as percentage of full scale reading.

For example, the accuracy of an instrument having full scale reading of 50 units may be expressed as $\pm 0.1\%$ of full scale reading. From this accuracy indication, practically accuracy is expressed in terms of limits of error. So for the accuracy limits specified above, there will be ± 0.05 units error in any measurement. So for a reading of 50 units, there will be error of ± 0.05 units i.e. $\pm 0.1\%$ while for a reading of 25 units, there will be error of ± 0.05 units in the reading i.e. $\pm 0.2\%$. Thus

as reading decreases, error in measurement is ± 0.05 units but net percentage error is more. Hence, specification of accuracy in this manner is highly misleading.

2) Accuracy as 'Percentage of True Value' : This is the best method of specifying the accuracy. It is to be specified in terms of the true value of quantity being measured. For example, it can be specified as $\pm 0.1\%$ of true value. This indicates that in such cases, as readings get smaller, error also gets reduced. Hence accuracy of the instrument is better than the instrument for which it is specified as percent of full scale reading.

3) Accuracy as 'Percentage of Scale Span' : For an instrument, if a_{max} , is the maximum point for which scale is calibrated, i.e. full scale reading and a_{min} is the lowest reading on scale. Then $(a_{max} - a_{min})$ is called scale span or span of the instrument. Accuracy of the instrument can be specified as percent of such scale span. Thus for an instrument having range from 25 units to 225 units, it can be specified as $\pm 0.2\%$ of the span i.e. $\pm [(0.2/100) \times (225 - 25)]$ which is ± 0.4 units error in any measurement.

4) Point Accuracy: Such an accuracy is specified at only one particular point of scale. It does not give any information about the accuracy at any other point on the scale. The general accuracy of an instrument cannot be specified, in this manner. But the general accuracy can be specified by providing a table of the point accuracy values calculated at various points throughout the entire range of the instrument.

Precision:

It is the measure of consistency or repeatability of measurements.

Let us see the basic difference between accuracy and precision. Consider an instrument on which, readings upto $1/1000$ th of unit can be measured. But the instrument has large zero adjustment error. Now every time reading is taken, it can be taken down upto $1/1000$ th of unit. So as the readings agree with each other, we say that the instrument is highly precise. But, though the readings are precise upto $1/1000$ th of unit, the readings are inaccurate due to large zero adjustment error. Every reading will be inaccurate, due to such error. Thus a precise instrument may not be accurate. Thus the precision means sharply or clearly defined and the readings agree among themselves. But there is no guarantee that readings are accurate. An instrument having zero error, if calibrated properly, can give accurate readings but in that case still, the readings can be obtained

down upto 1~00th of unit only. Thus accuracy can be improved by calibration but not the precision of the instrument.

The precision is composed of two characteristics:

- Conformity and
- Number of significant figures.

Conformity:

Consider a resistor having true value as 2385692 Ω , which is being measured by an ohmmeter. Now, the meter is consistently measuring the true value of the resistor. But the reader, can read consistently, a value as 2.4 MD due to nonavailability of proper scale. The value 2.4 MO is estimated by the reader from the available scale. There are no deviations from the observed value. The error created due to the limitation of the scale reading is a precision error.

The example illustrates that the conformity is a necessary, but not sufficient condition for precision. Similarly, precision is necessary but not the sufficient condition for accuracy.

Significant Figures:

The precision of the measurement is obtained from the number of significant figures, in which the reading is expressed. The significant figures convey the actual information about the magnitude and the measurement precision of the quantity.

The precision can be mathematically expressed as :

$$P = 1 - \left| \frac{X_n - \bar{X}_n}{\bar{X}_n} \right|$$

where

P = Precision

X_n = Value of n^{th} measurement

\bar{X}_n = Average of the set of measured values

Example:

The table shows the set of 5 measurements recorded in a laboratory. Calculate the precision of the 3rd measurement

Measurement Number	Value of Measurement
1	49
2	51
3	52
4	50
5	49

Solution : The average value for the set of measurements is,

$$\bar{X}_n = \frac{\text{Sum of the readings}}{\text{Number of readings}} = \frac{251}{5} = 50.2$$

The value of 3rd measurement is $X_n = 52$ where $n = 3$

$$\therefore P = 1 - \left| \frac{X_n - \bar{X}_n}{\bar{X}_n} \right| = 1 - \left| \frac{52 - 50.2}{50.2} \right| = 0.964 \text{ i.e. } 96.4 \%$$

This is the precision of the 3rd measurement.

Errors:

The most important static characteristics of an instrument is its accuracy, which is generally expressed in terms of the error called static error.

Mathematically it can be expressed as,

$$e = A_t - A_m$$

where

e = Error

A_m = Measured value of the quantity

A_t = True value of the quantity

In this expression, the error denoted as e is also called absolute error. The absolute error does not indicate precisely the accuracy of the measurements. For example, absolute error of ± 1 V is negligible when the voltage to be measured is of the order of 1000 V but the same error of ± 1 V

becomes significant when the voltage under measurement is 5 V or so. Hence, generally instead of specifying absolute error, the relative or percentage error is specified.

Mathematically, the **relative error** can be expressed as,

$$e_r = \frac{\text{Absolute Error}}{\text{True value}} = \frac{\text{True value} - \text{Measured value}}{\text{True value}}$$

$$= \frac{A_t - A_m}{A_t}$$

The percentage relative error is expressed as,

$$\% e_r = \frac{A_t - A_m}{A_t} \times 100$$

From the **relative percentage error**, the accuracy can be mathematically expressed as,

$$A = 1 - e_r = 1 - \left| \frac{A_t - A_m}{A_t} \right|$$

where A = Relative accuracy

and $a = A \times 100 \%$

where a = Percentage accuracy

The error can also be expressed as a percentage of full scale reading as,

$$\text{Error as a percentage of full scale reading} = \frac{A_t - A_m}{\text{f.s.d.}} \times 100$$

where f.s.d. = Full scale deflection

If the calibration curve is not linear as shown in the Fig. 1.3 (b), then the sensitivity varies with the input. The sensitivity is always expressed by the manufacturers as the ratio of the magnitude of quantity being measured to the magnitude of the response. Actually, this definition is the reciprocal of the sensitivity is called inverse sensitivity or deflection factor. But manufacturers call this inverse sensitivity as a sensitivity.

Inverse sensitivity = Deflection factor

$$\text{Deflection factor} = \frac{1}{\text{Sensitivity}} = \frac{\Delta q_i}{\Delta q_o}$$

The units of the sensitivity are millimeter per micro-ampere, millimeter per ohm, counts per volt, etc. while the units of a deflection factor are micro-ampere per millimeter, ohm per millimeter, volts per count, etc. The sensitivity of the instrument should be as high as possible and to achieve this range of an instrument should not greatly exceed the value to be measured.

Resolution:

It is the smallest increment of quantity being measured which can be detected with certainty by an instrument.

So if a nonzero input quantity is slowly increased, output reading will not increase until some minimum change in the input takes place. This minimum change which causes the change in the output is called resolution. The resolution of an instrument is also referred to as discrimination of the instrument. The resolution can affect the accuracy of the measurement.

Dynamic error:

It is the difference between the true value of the variable to be measured, changing with time and the value indicated by the measurement system, assuming zero static error.

The Fig. 1.13 shows the dead time, i.e. time delay and the dynamic error.

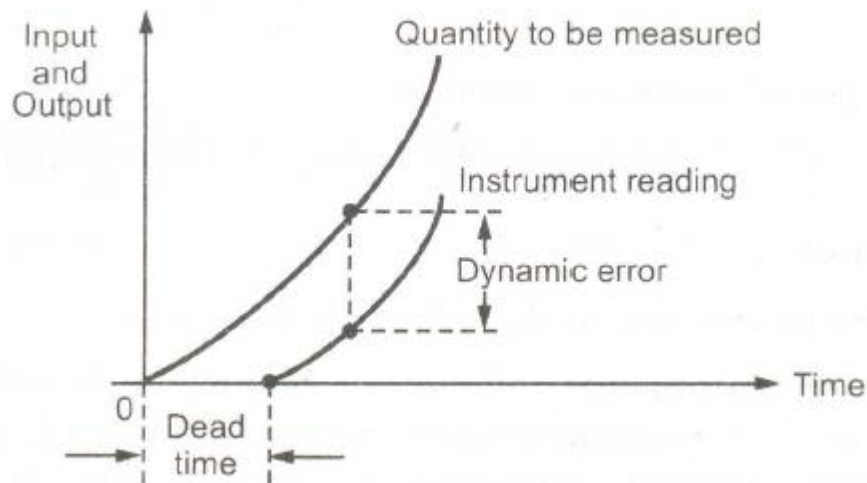

Types of errors:

The static error is defined earlier as the difference between the true value of the variable and the value indicated by the instrument. The static error may arise due to number of reasons. The static errors are classified as:

- 1) Gross errors
- 2) Systematic errors
- 3) Random errors

Gross errors:

The gross errors mainly occur due to carelessness or lack of experience of a human being. These cover human mistakes in readings, recordings and calculating results. These errors also occur due to incorrect adjustments of instruments. These errors cannot be treated mathematically. These errors are also called personal errors. Some gross errors are easily detected while others are very difficult to detect.

Systematic errors:

The systematic errors are mainly resulting due to the shortcomings of the instrument and the characteristics of the material used in the instrument, such as defective or worn parts, ageing effects, environmental effects, etc.

A constant uniform deviation of the operation of an instrument is known as a systematic error.

There are three types of systematic errors as

- 1) Instrumental errors 2) Environmental errors 3) Observational errors

Random errors:

Some errors still result, though the systematic and instrumental errors are reduced or at least accounted for. The causes of such errors are unknown and hence, the errors are called **random** errors. These errors cannot be determined in the ordinary process of taking the measurements.

Absolute and relative errors:

When the error is specified in terms of an absolute quantity and not as a percentage, then it is called an absolute error.

Thus the voltage of 10 ± 0.5 V indicated ± 0.5 V as an absolute error. When the error is expressed as a percentage or as a fraction of the total quantity to be measured, then it is called relative error.

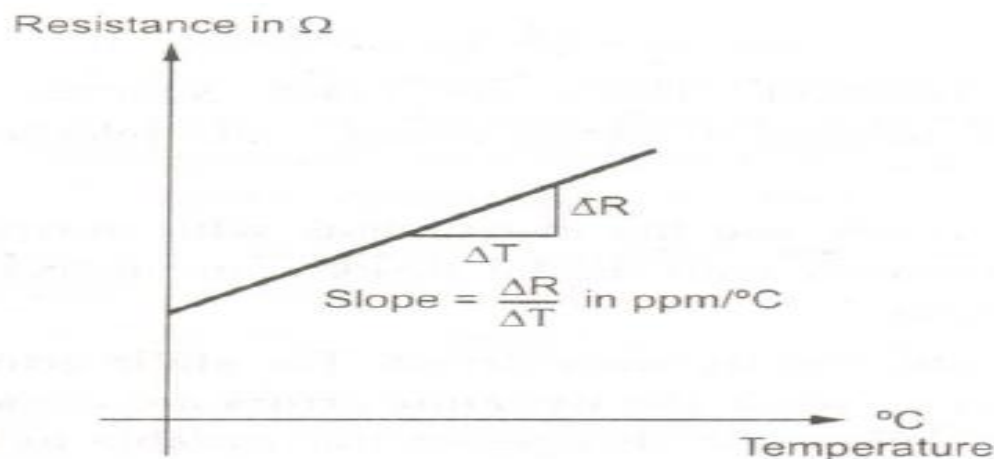

Generally the relative error in case of resistances is specified as percentage tolerances. Another method of expressing error is by specifying it as parts per million (ppm), relative to the total quantity. So it is a relative error specification. Generally change in resistance with temperature is indicated in ppm. $^{\circ}\text{C}$ shows the variation in resistance with Temperature temperature. Thus if a resistance of 100 k Ω . Has a temperature coefficient of 50 ppm/ $^{\circ}\text{C}$ means 50 parts per millionth per degree celcius. Thus one millionth of 100 kohm. is 0.1 ohm and 50 such parts means 5 D. Th1-1s 1" change in temperature causes change of 5 D in 100 kohm. resistor.

Limiting errors:

The manufacturers specify the accuracy of the instruments within a certain percentage of full scale reading. The components like the resistor, inductor, capacitor are guaranteed to be within a certain percentage of rated value. This percentage indicates the deviations from the nominal or specified value of the particular quantity. These deviations from the specified value are called **Limiting Errors**. These are also called **Guarantee Errors**.

Thus the actual value with the limiting error can be expressed mathematically as,

$$A_a = A_s \pm \delta A$$

where

A_a = Actual value

A_s = Specified or rated value

δA = Limiting error or tolerance

Relative limiting error:

This is also called fractional error. It is the ratio of the error to the specified magnitude of a quantity.

Thus

$$e = \frac{\delta A}{A_s}$$

where e = Relative timing error

From the above equation, we can write,

$$\delta A = e \cdot A_s$$

and

$$\begin{aligned} A_a &= A_s \pm \delta A \\ &= A_s \pm e A_s \end{aligned}$$

∴

$$A_a = A_s [1 \pm e]$$

The percentage relative limiting error is expressed as

$$\% e = e \times 100$$

The relative limiting error can be also be expressed as,

$$e = \frac{\text{Actual value } (A_a) - \text{Specified value } (A_s)}{\text{Specified value } (A_s)}$$

Voltmeters and multimeters:

Basic meter:

A basic d.c. meter uses a motoring principle for its operation. It states that any current carrying coil placed in a magnetic field experiences a force, which is proportional to the magnitude of current passing through the coil. This movement of coil is called D'Arsonval movement and basic meter is called D'Arsonval galvanometer.

D.C instruments:

- a) Using shunt resistance, d.c. current can be measured. The instrument is d.c. microammeter, milliammeter or ammeter.
- b) Using series resistance called multiplier, d.c. voltage can be measured. The instrument is d.c. millivoltmeter, voltmeter or kilovoltmeter.
- c) Using a battery and resistive network, resistance can be measured. The instrument is ohmmeter.

A.C instruments:

- a) Using a rectifier, a.c. voltages can be measured, at power and audio frequencies. The instrument is a.c. voltmeter.
- b) Using a thermocouple type meter radio frequency (RF) voltage or current can be measured.
- c) Using a thermistor in a resistive bridge network, expanded scale for power line voltage can be obtained.

Basic DC voltmeter:

The basic d.c. voltmeter is nothing but a permanent magnet moving coil (PMMC) or Arsonval galvanometer. The resistance is required to be connected in series with the basic meter to use it as a voltmeter. This series resistance is called a **multiplier**. The main function of the multiplier is to limit the current through the basic meter so that the meter current does not exceed the full scale deflection value. The voltmeter measures the voltage across the two points of a circuit or a voltage across a circuit component. The basic d.c. voltmeter is shown in the Fig.

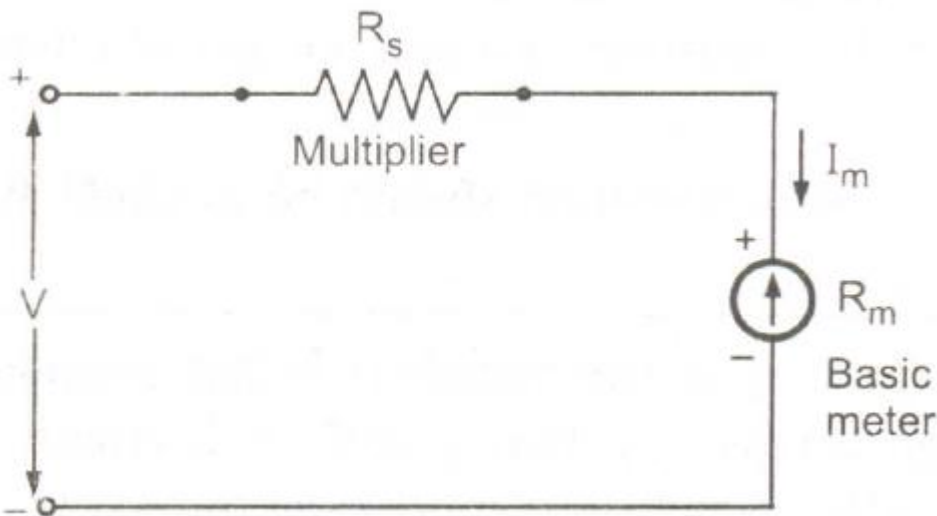

The voltmeter must be connected across the two points or a component, to measure the potential difference, with the proper polarity.

The multiplier resistance can be calculated as:

Let R_m = internal resistance of coil i.e. meter

R_s = series multiplier resistance

I_m = full scale deflection current

V = full range voltage to be measured

From Fig. 2.1, $\therefore V = I_m (R_m + R_s)$

$$\therefore V = I_m R_m + I_m R_s$$

$$\therefore I_m R_s = V - I_m R_m$$

$$\therefore R_s = \frac{V}{I_m} - R_m$$

The multiplying factor for multiplier is the ratio of full range voltage to be measured and the drop across the basic meter.

Let v = drop across the basic meter = $I_m R_m$

$\therefore m$ = multiplying factor = $\frac{V}{v}$

$$= \frac{I_m (R_m + R_s)}{I_m R_m}$$

$$m = 1 + \frac{R_s}{R_m}$$

Hence multiplier resistance can also be expressed as,

$$R_s = (m - 1) R_m$$

Multirange voltmeters:

The range of the basic d.c. voltmeter can be extended by using number of multipliers and a selector switch. Such a meter is called **multirange** voltmeter

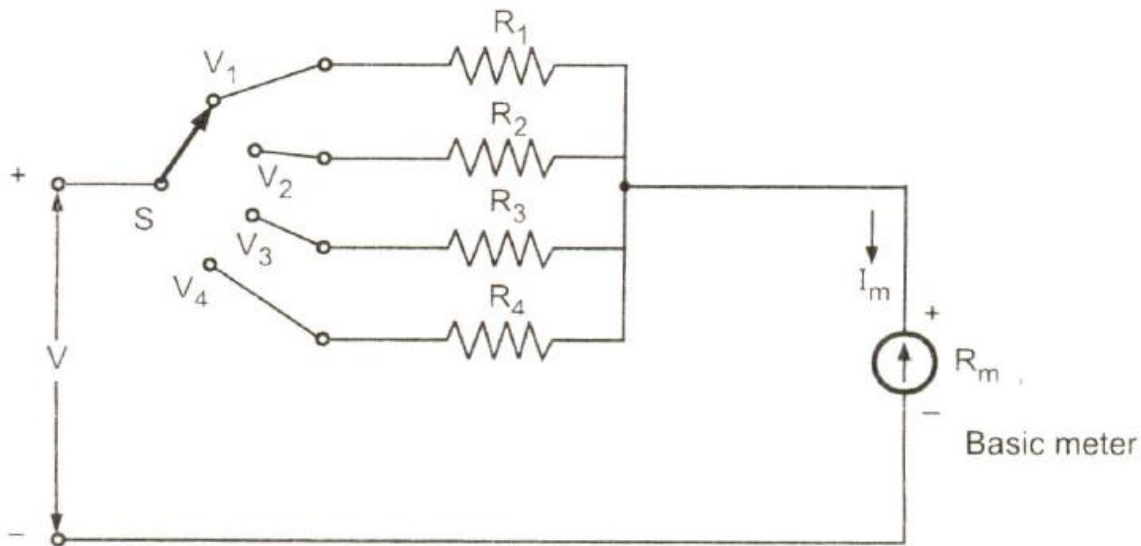

Multirange voltmeter

The \$R_1\$, \$R_2\$, \$R_3\$ and \$R_4\$ are the four series multipliers. When connected in series with the meter, they can give four different voltage ranges as \$V_1\$, \$V_2\$, \$V_3\$, and \$V_4\$. The selector switch \$S\$ is multiposition switch by which the required multiplier can be selected in the circuit.

The mathematical analysis of basic d.c. *voltmeter* is equally applicable for such multirange *voltmeter*. Thus,

$$R_1 = \frac{V_1}{I_m} - R_m \quad R_2 = \frac{V_2}{I_m} - R_m \quad \text{and so on.}$$

Sensitivity of voltmeters:

In a multirange voltmeter, the ratio of the total resistance R_r to the voltage range remains same. This ratio is nothing but the reciprocal of the full scale deflection current, of the meter i.e. $1/I_m$. This value is called sensitivity of the voltmeter. Thus the sensitivity of the voltmeter is defined ,

$$S = \frac{1}{\text{Full scale deflection current}}$$

$$S = \frac{1}{I_m} \Omega/V \text{ or } k\Omega/V$$

Loading effect:

While selecting a meter for a particular measurement, the sensitivity rating is very important. A low sensitive meter may give the accurate reading in low resistance circuit but will produce totally inaccurate reading in high resistance circuit.

The voltmeter is always connected across the two points between which the potential difference is to be measured. If it is connected across a low resistance then as voltmeter resistance is high, most of the current will pass through a low resistance and will produce the voltage drop which will be nothing but the true reading. But if the voltmeter is connected across the high resistance then due to two high resistances in parallel, the current will divide almost equally through the two paths. Thus the meter will record the voltage drop across the high resistance which will be much lower than the true reading. Thus the low sensitivity instrument when used in high resistance circuit gives a lower than the true reading. This is called loading effect of the voltmeters. It is mainly caused due to low sensitivity instruments.

A.C voltmeters using rectifier:

The PMMC movement used in d.c. voltmeters can be effectively used in a.c. voltmeters. The rectifier is used to convert a.c. voltage to be measured, to d.c. This d.c., if required is amplified and then given to the PMMC movement. The PMMC movement gives the deflection proportional to the quantity to be measured.

The r.m.s. value of an alternating quantity is given by that steady current (d.c.) which when flowing through a given circuit for a given time produces the same amount of heat as produced by the alternating current which when flowing through the same circuit for the same time. The r.m.s value is calculated by measuring the quantity at equal intervals for one complete cycle. Then squaring each quantity, the average of squared values is obtained. The square root of this average value is the r.m.s. value. The r.m.s means root-mean square i.e. squaring, finding the mean i.e. average and finally root.

If the waveform is continuous then instead of squaring and calculating mean, the integration is used. Mathematically the r.m.s. value of the continuous a.c. voltage having time period T is given by,

$$V_{\text{rms}} = \sqrt{\frac{1}{T} \int_0^T V_{\text{in}}^2 dt}$$

The $\frac{1}{T}$ term indicates the mean value or average value.

For purely sinusoidal quantity,

$$V_{\text{rms}} = 0.707 V_m$$

where $V_m =$ peak value of the sinusoidal quantity

If the a.c. quantity is continuous then average value can be expressed mathematically using an integration as,

$$V_{av} = \frac{2}{T} \int_0^{T/2} V_{in} dt$$

The interval $T/2$ indicates the average over half a cycle.

For purely sinusoidal quantity,

$$V_{av} = \frac{2}{\pi} V_m = 0.636 V_m$$

where

V_m = Peak value of the sinusoidal quantity.

The form factor is the ratio of r.m.s. value to the average value of an alternating quantity.

$$K_f = \frac{\text{r.m.s. value}}{\text{average value}} = \text{form factor}$$

Basic rectifier type voltmeter:

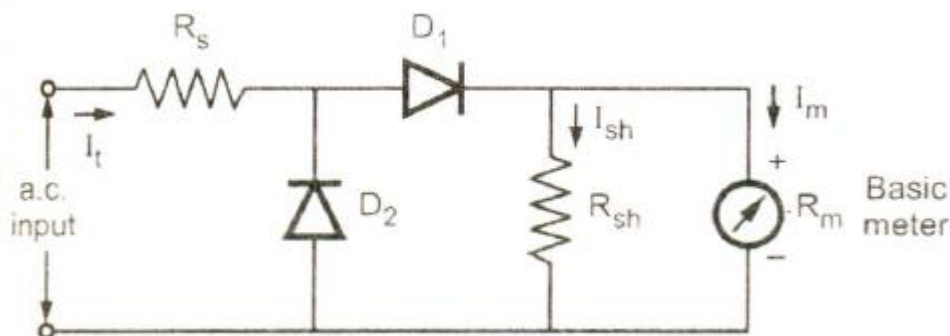

The diodes D_1 and D_2 are used for the rectifier circuit. The diodes show the nonlinear behaviour for the low currents hence to increase the current through diode D_1 , the meter is shunted with a resistance R_{sh} . This ensures high current through diode and its linear behaviour.

When the a.c. input is applied, for the positive half cycle, the diode D_1 conducts and causes the meter deflection proportional to the average value of that half cycle. In the negative cycle, the

diode D_2 conducts and D_1 is reverse biased. The current through the meter is in opposite direction and hence meter movement is bypassed. Thus due to diodes, the rectifying action produces pulsating d.c. and the meter indicates the average value of the input.

A.C voltmeter using fullwave rectifier:

The a.c. voltmeter using full wave rectifier is achieved by using bridge rectifier consisting of four diodes, as shown in the Fig

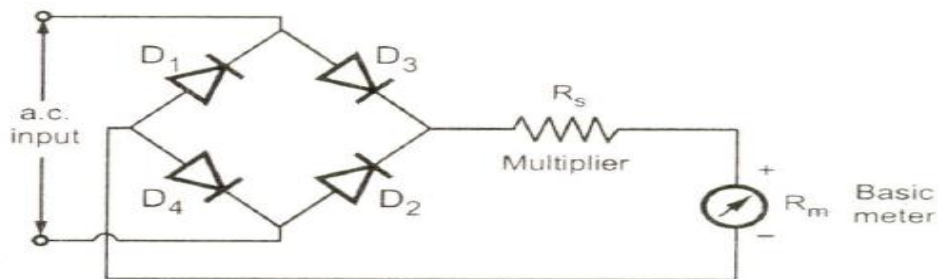

Electronic multimeter:

For the measurement of d.c. as well as a.c. voltage and current, resistance, an electronic multimeter is commonly used. It is also known as Voltage-Ohm Meter (VOM) or multimeter. The important salient features of VOM are as listed below.

- 1) The basic circuit of VOM includes balanced bridge d.c. amplifier.
- 2) To limit the magnitude of the input signal, RANGE switch is provided. By properly adjusting input attenuator input signal can be limited.
- 3) It also includes rectifier section which converts a.c. input signal to the d.c. voltage.
- 4) It facilitates resistance measurement with the help of internal battery and additional circuitry.
- 5) The various parameters measurement is possible by selecting required function using FUNCTION switch.
- 6) The measurement of various parameters is indicated with the help of indicating Meter.

Use of multimeter for D.C measurement:

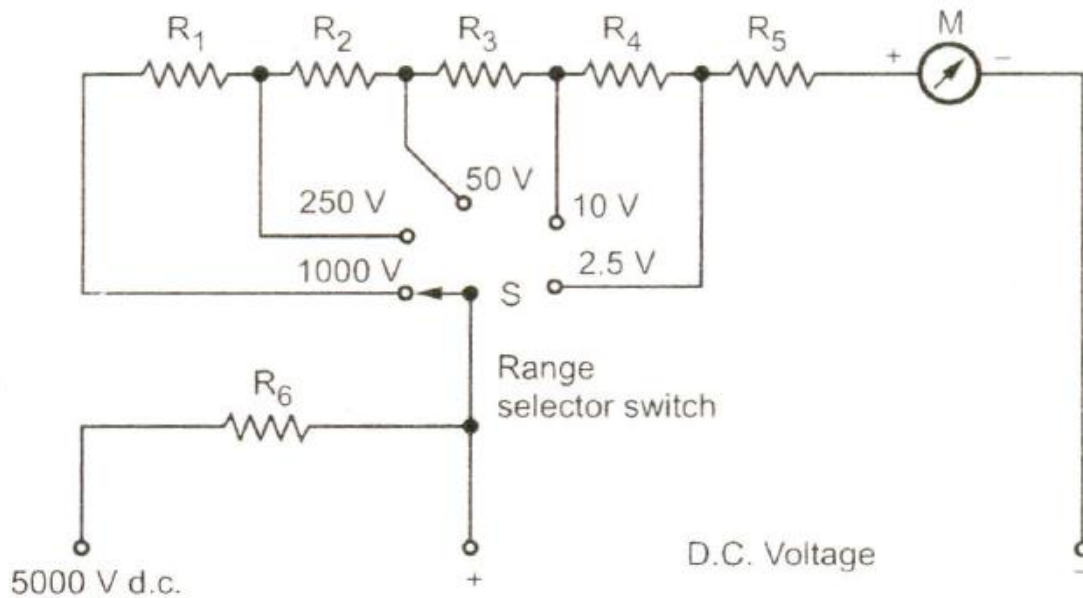

For getting different ranges of voltages, different series resistances are connected in series which can be put in the circuit with the range selector switch. We can get different ranges to measure the d.c. voltages by selecting the proper resistance in series with the basic meter.

Use of multimeter as ammeter:

To get different current ranges, different shunts are connected across the meter with the help of range selector switch. The working is same as that of PMMC ammeter

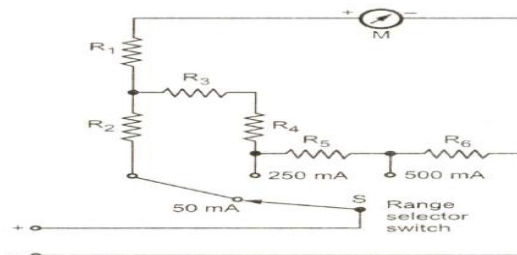

Use of multimeter for measurement of A.C. voltage:

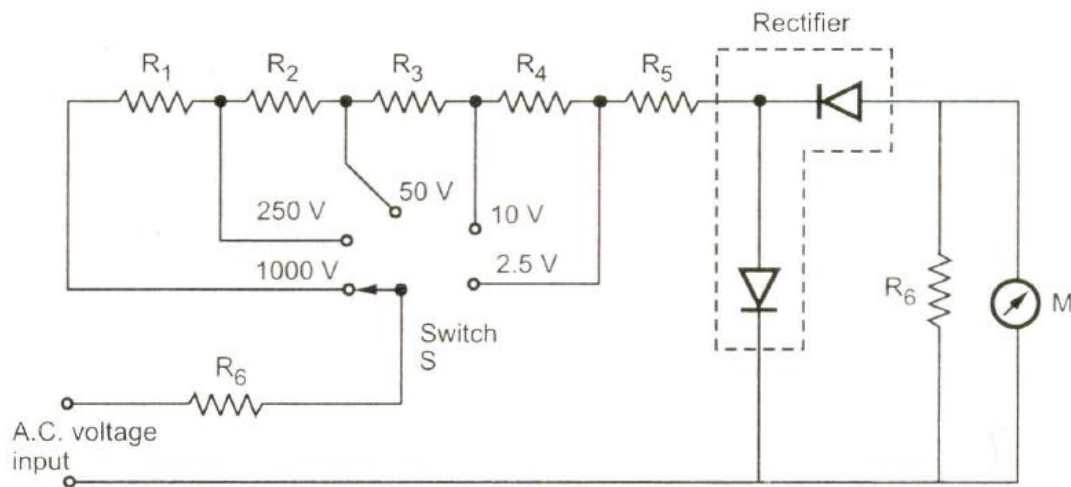

The rectifier used in the circuit rectifies a.c. voltage into d.c. voltage for measurement of a.c. voltage before current passes through the meter. The other diode is used for the protection purpose.

Use of multimeter for resistance measurement:

The Fig shows ohmmeter section of multimeter for a scale multiplication of 1. Before any measurement is made, the instrument is short circuited and "zero adjust" control is varied until the meter reads zero resistance i.e. it shows full scale current. Now the circuit takes the form of a variation of the shunt type ohmmeter. Scale multiplications of 100 and 10,000 can also be used for measuring high resistances. Voltages are applied the circuit with the help of battery.

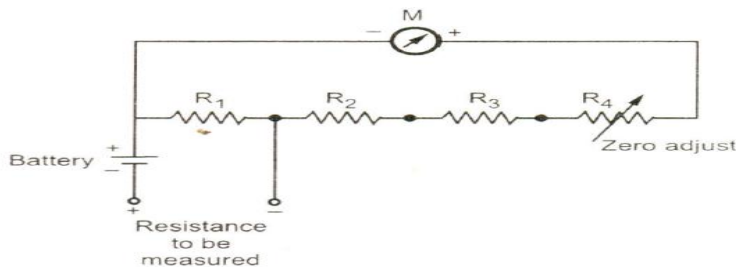

Recommended questions:

1. What is measurement? What are the two basic requirements of any measurement?
2. List the advantages of an electronic measurement.
3. Define and explain the term 'Calibration'.
4. How are the performance characteristics of an instrument classified?
5. Define and explain the following static characteristics of an instrument :
 i) Accuracy ii) Precision iii) Static error iv) Resolution
 v) Sensitivity vi) Threshold vii) Zero drift viii) Reproducibility [Jan 05, 08 Jul 07]
 ix) Linearity and x) Stability
6. Explain how the accuracy can be specified for an instrument.
7. Distinguish clearly between accuracy and precision.
8. State and explain the characteristics of precision.
9. Explain the terms relative error and relative percentage error.
10. What is the scale span of an instrument?
11. Define a dynamic response of an instrument.
12. Define the following terms,
 i) Speed of response ii) Lag iii) Fidelity iv) Dynamic error.
13. Define and explain the types of errors possible in an instrument.
14. Define limiting errors. Derive the expression for relative limiting error.
15. A moving coil voltmeter has a uniform scale with 100 divisions, the full scale reading is 200 V and 1/10 of scale division can be estimated with a fair degree of certainty. Determine the resolution of the instrument in volt. [Ans. : 0.2 V] [Jul 06, 09]
16. A digital voltmeter has a read out range from 0-9999 counts. Determine the resolution of the instrument in volt when the full scale reading is 9.999 V. [Ans. : 1 mV] [Jan 05, 07. Jul 09]
17. A true value of voltage across a resistor is 50 V. The instrument reads 49 V. Calculate
 i) absolute error ii) percentage error iii) percentage accuracy.
18. What is the sensitivity of voltmeters? Explain.
19. What is a loading effect? Explain with a suitable example.
20. Explain the operation of a basic d.c. voltmeter.
21. Explain the working of a d.c. multirange voltmeter.

Unit:II

Hrs: 07

Syllabus:

Digital Instruments

Digital Voltmeters – Introduction, DVM's based on $V - T$, $V - F$ and Successive approximation principles, Resolution and sensitivity, General specifications, Digital Multi-meters, Digital frequency meters, Digital measurement of time(Text 1: 5.1 to 5.6; 5.9 and 5.10; 6.1 to 6.4)

Recommended readings:

1. “Electronic Instrumentation”, H. S. Kalsi, TMH, 2004
2. “Electronic Instrumentation and Measurements”, David A Bell, PHI / Pearson Education, 2006.

Unit 2:**Digital Instruments****07 Hours****Introduction:**

The digital voltmeters generally referred as DVM, convert the analog signals into digital and display the voltages to be measured as discrete numericals instead of pointer deflection, on the digital displays. Such voltmeters can be used to measure a.c. and d.c. voltages and also to measure the quantities like pressure, temperature, stress etc. using proper transducer and signal conditioning circuit. The transducer converts the quantity into the proportional voltage signal and signal conditioning circuit brings the signal into the proper limits which can be easily measured by the digital voltmeter. The output voltage is displayed on the digital display on the front panel. Such a digital output reduces the human reading and interpolation errors and parallax errors. The DVMs have various features and the advantages, over the conventional analog voltmeters having pointer deflection on the continuous scale.

Performance parameters of digital voltmeters:**1. Number of measurement ranges:**

The basic range of any DVM is either 1V or 10 V. With the help of attenuator at the input, the range can be extended from few microvolts to kilovolts.

2. Number of digits in readout: The number of digits of DVMs vary from 3 to 6. More the number of digits, more is the resolution.

3. Accuracy: The accuracy depends on resolution and resolution on number of digits. Hence more number of digits means more accuracy. The accuracy is as high upto $\pm 0.005\%$ of the reading.

4. Speed of the reading: In the digital voltmeters, it is necessary to convert analog signal into digital signal. The various techniques are used to achieve this conversion. The circuits which are used to achieve such conversion are called digitizing circuits and the process is called digitizing. The time required for this conversion is called digitizing period. The maximum speed of reading and the digitizing period are interrelated. The instrument user must wait, till a stable reading is obtained as it is impossible to follow the visual readout at high reading speeds.

5. Normal mode noise rejection: This is usually obtained through the input filtering or by use of the integration techniques. The noise present at the input, if passed to the analog to digital

converting circuit then it can produce the error, especially when meter is used for low voltage measurement. Hence noise is required to be filtered.

6. **Common mode noise rejection** : This is usually obtained by guarding. A guard is a sheet metal box surrounding the circuitry. A terminal at the front panel makes this 'box' available to the circuit under measurement.

7. **Digital output of several types**: The digital readout of the instrument may be 4 line BCD, single line serial output etc. Thus the type of digital output also determines the variety of the digital voltmeter.

8. **Input impedance** : The input impedance of DVM must be as high as possible which reduces the loading effects. Typically it is of the order of 10 :M.ohm.

Block diagram of DVM:

Any digital instrument requires analog to digital converter at its input. Hence first block in a general DVM is ADC as shown in the Fig.

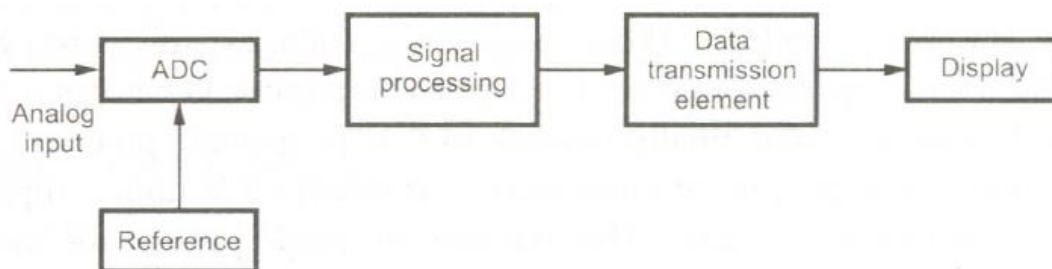

Every ADC requires a reference. The reference is generated internally and reference generator circuitry depends on the type of ADC technique used. The output of ADC is decoded and signal is processed in the decoding stage. Such a decoding is necessary to drive the seven segment display. The data from decoder is then transmitted to the display. The data transmission element may be a latches, counters etc. as per the requirement. A digital display shows the necessary digital result of the measurement.

Ramp type DVM:

Linear ramp technique:

The basic principle of such measurement is based on the measurement of the time taken by a linear ramp to rise from a V to the level of the input voltage or to decrease from the level of the

input voltage to zero. This time is measured with the help of electronic time interval counter and the count is displayed in the numeric form with the help of a digital display.

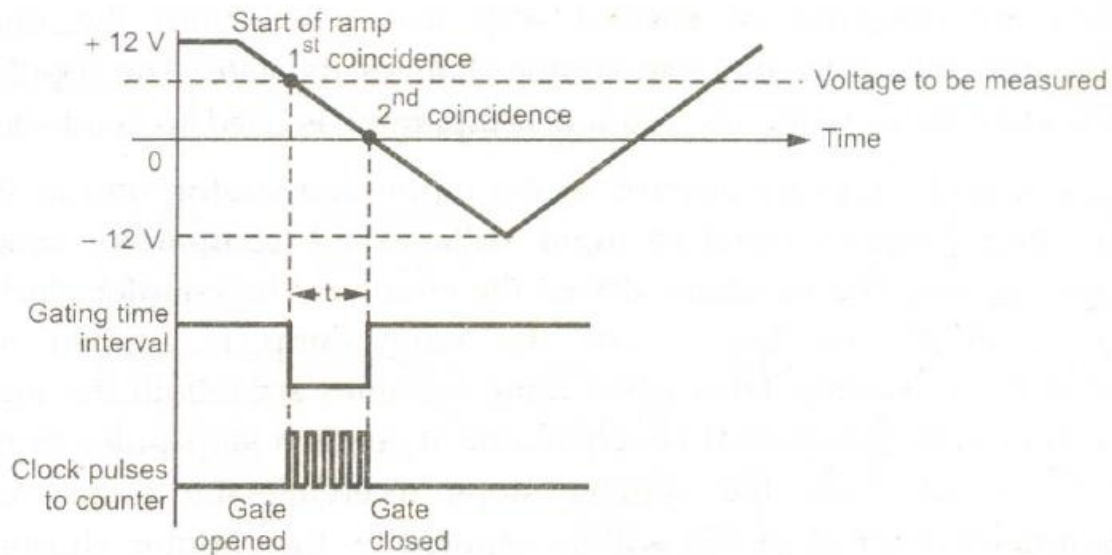

Basically it consists of a linear ramp which is positive going or negative going. The range of the ramp is ± 12 V while the base range is ± 10 V. The conversion from a *voltage* to a time interval is shown in the fig

At the start of measurement, a ramp *voltage* is initiated which is continuously compared with the input voltage. When these two voltages are same, the comparator generates a pulse which opens a gate i.e. the input comparator generates a start pulse. The ramp continues to decrease and finally reaches to 0 V or ground potential. This is sensed by the second comparator or ground comparator. At exactly 0 V, this comparator produces a stop pulse which closes the gate. The number of clock pulses are measured by the counter. Thus the time duration for which the gate is opened, is proportional to the input voltage. In the time interval between start and stop pulses, the gate remains open and the oscillator circuit drives the counter. The magnitude of the count indicates the magnitude of the input voltage, which is displayed by the display. The block diagram of linear ramp DVM is shown in the Fig

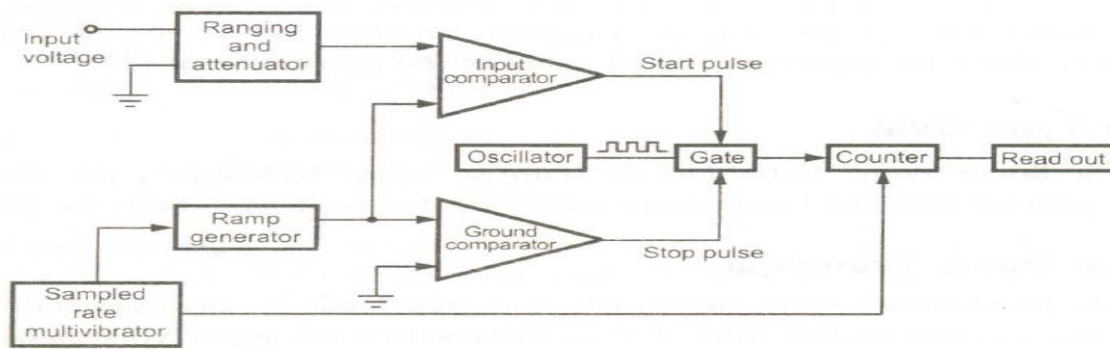

Properly attenuated input signal is applied as one input to the input comparator. The ramp generator generates the proper linear ramp signal which is applied to both the comparators. Initially the logic circuit sends a reset signal to the counter and the readout. The comparators are designed in such a way that when both the input signals of comparator are equal then only the comparator changes its state. The input comparator is used to send the start pulse while the ground comparator is used to send the stop pulse.

When the input and ramp are applied to the input comparator, and at the point when negative going ramp becomes equal to input voltages the comparator sends start pulse, due to which gate opens. The oscillator drives the counter. The counter starts counting the pulses received from the oscillator. Now the same ramp is applied to the ground comparator and it is decreasing. Thus when ramp becomes zero, both the inputs of ground comparator becomes zero (grounded) i.e. equal and it sends a stop pulse to the gate due to which gate gets closed. Thus the counter stops receiving the pulses from the local oscillator. A definite number of pulses will be counted by the counter, during the start and stop pulses which is measure of the input voltage. This is displayed by the digital readout.'

The sample rate multivibrator determines the rate at which the measurement cycles are initiated. The oscillation of this multivibrator is usually adjusted by a front panel control named rate, from few cycles per second to as high as 1000 or more cycles per second. The typical value is 5 measuring cycles/second with an accuracy of $\pm 0.005\%$ of the reading. The sample rate provides an initiating pulse to the ramp generator to start its next ramp voltage. At the same time, a reset pulse is also generated which resets the counter to the zero state.

Dual slope integrating type DVM:

This is the most popular method of analog to digital conversion. In the ramp techniques, the noise can cause large errors but in dual slope method the noise is averaged out by the positive and negative ramps using the process of integration. The basic principle of this method is that the input signal is integrated for a fixed interval of time. And then the same integrator is used to integrate the reference voltage with reverse slope. Hence the name given to the technique is **dual** slope integration technique.

The block diagram of dual slope integrating type DVM is shown in the Fig. It consists of five blocks, an op-amp used as an integrator, a zero comparator, clock pulse generator, a set of decimal counters and a block of control logic.

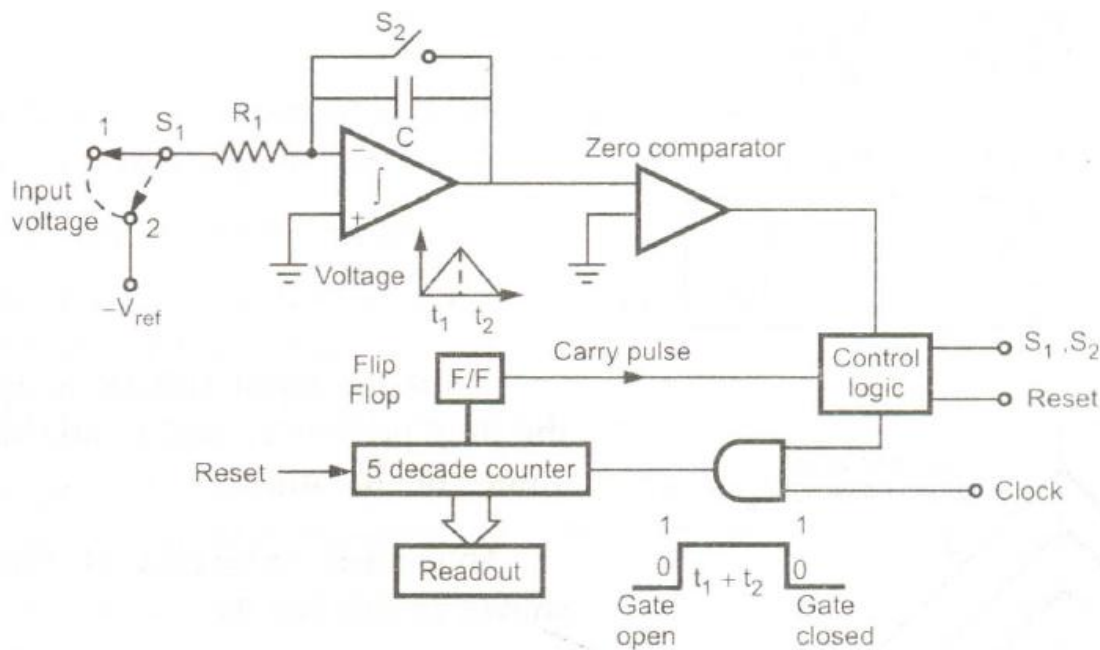

When the switch S_1 is in position 1, the capacitor C starts charging from zero level. The rate of charging is proportional to the input voltage level. The output of the op-amp is given by,

$$V_{out} = -\frac{1}{R_1 C} \int_0^{t_1} V_{in} dt$$

$$V_{out} = -\frac{V_{in} t_1}{R_1 C}$$

where

t_1 = Time for which capacitor is charged

V_{in} = Input voltage

R_1 = Series resistance

C = Capacitor in feedback path

After the interval t_1 , the input voltage is disconnected and a negative voltage $-V_{ref}$ is connected by throwing the switch S_1 in position 2. In this position, the output of the op-amp is given by,

$$V_{out} = \frac{1}{R_1 C} \int_0^{t_2} -V_{ref} dt$$

$$V_{out} = -\frac{V_{ref} t_2}{R_1 C}$$

Subtracting (1) from (2),

$$V_{out} - V_{out} = 0 = \frac{-V_{ref} t_2}{R_1 C} - \left(\frac{-V_{in} t_1}{R_1 C} \right)$$

$$\therefore \frac{V_{ref} t_2}{R_1 C} = \frac{V_{in} t_1}{R_1 C}$$

$$\therefore V_{ref} t_2 = V_{in} t_1$$

$$V_{in} = V_{ref} \cdot \frac{t_2}{t_1}$$

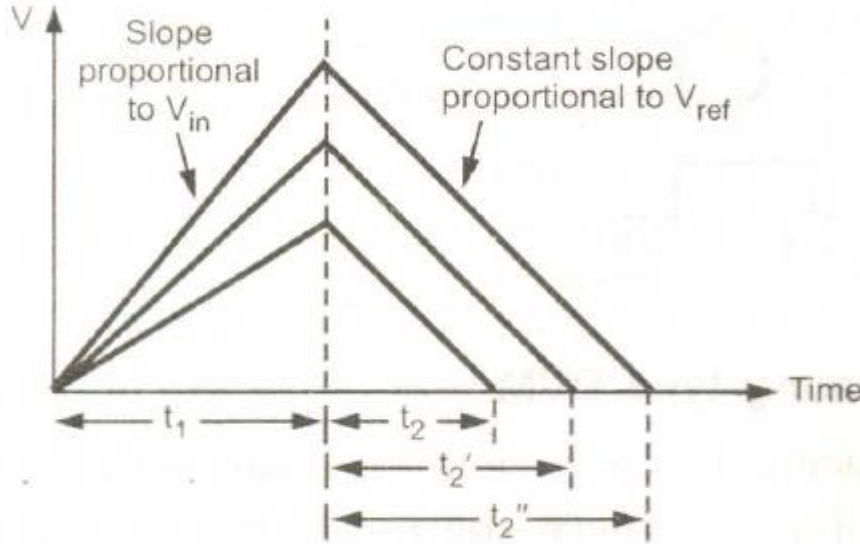

Thus the input voltage is dependent on the time periods t_1 and t_2 and not on the values of R and C . This basic principle of this method is shown in the Fig.

At the start of the measurement, the counter is reset to zero. The output of the flip-flop is also zero. This is given to the control logic. This control sends a signal so as to close an electronic switch to position 1 and integration of the input voltage starts. It continues till the time period t_1 .

As the output of the integrator changes from its zero value, the zero comparator output changes its state. This provides a signal to control logic which in turn opens the gate and the counting of the clock pulses starts.

The counter counts the pulses and when it reaches to 9999, it generates a carry pulse and all digits go to zero. The flip flop output gets activated to the logic level T. This activates the control logic. This sends a signal which changes the switch position from 1 to 2. Thus $-V_{ref}$ gets connected to op-amp. As V_{ref} polarity is opposite, the capacitor starts discharging. The integrator output will have constant negative slope as shown in the Fig. 3.5.1. The output decreases linearly and after the interval t_2 , attains zero value, when the capacitor C gets fully discharged.

From equation (3) we can write,

$$V_{in} = V_{ref} \cdot \frac{t_2}{t_1}$$

Let time period of clock oscillator be T and digital counter has counted the counts n_1 and n_2 during the period t_1 and t_2 respectively.

$$V_{in} = V_{ref} \cdot \frac{n_2 T}{n_1 T} = V_{ref} \cdot \frac{n_2}{n_1}$$

Thus the unknown voltage measurement is not dependent on the clock frequency, but dependent on the counts measured by the counter.

The advantages of this technique are:

- i) Excellent noise rejection as noise and superimposed a.c. are averaged out during the process of integration.
- ii) The RC time constant does not affect the input voltage measurement.
- iii) The capacitor is connected via an electronic switch. This capacitor is an auto zero capacitor and avoids the effects of offset voltage.
- iv) The integrator responds to the average value of the input hence sample and hold circuit is not necessary.
- v) The accuracy is high and can be readily varied according to the specific requirements.

The only disadvantage of this type of DVM is its slow speed.

V – F converter type integrating DVM:

In case of ramp type DVM, the voltage is converted to time. The time and frequency are related to each other. Thus the voltage can be converted to frequency for the measurement purpose. A train of pulses, whose frequency depends upon the voltage being measured, is generated. Then the number of pulses appearing in a definite interval of time is counted. Since the frequency of these pulses is a function of the unknown voltage, the number of pulses counted in that period of time is the indication of the unknown input voltage.

The heart of such integrating type of DVM is the operational amplifier used as an integrator. The input voltage is integrated for a fixed interval. An integration of a constant input voltage results a ramp at the output, the slope of which is proportional to the input voltage. If the input is positive, the output of op-amp is negative going ramp. After some time, the capacitor is

discharged to 0, thus output returns back to zero and the next cycle begins. Hence the waveform at the output is a sawtooth waveform as shown in the Fig.



If the input signal is doubled, the number of teeth in the output signal per unit time will be also doubled. Thus the frequency of the output will be doubled. Thus the frequency of the output is proportional to the input voltage. This is nothing but the voltage to frequency conversion.

The sawtooth pulses are finally enter into a reversible counter. The measured value by the reversible counter is finally displayed with the help of digital readout.

The block diagram of voltage to frequency converter type integrating DVM is shown in the Fig.

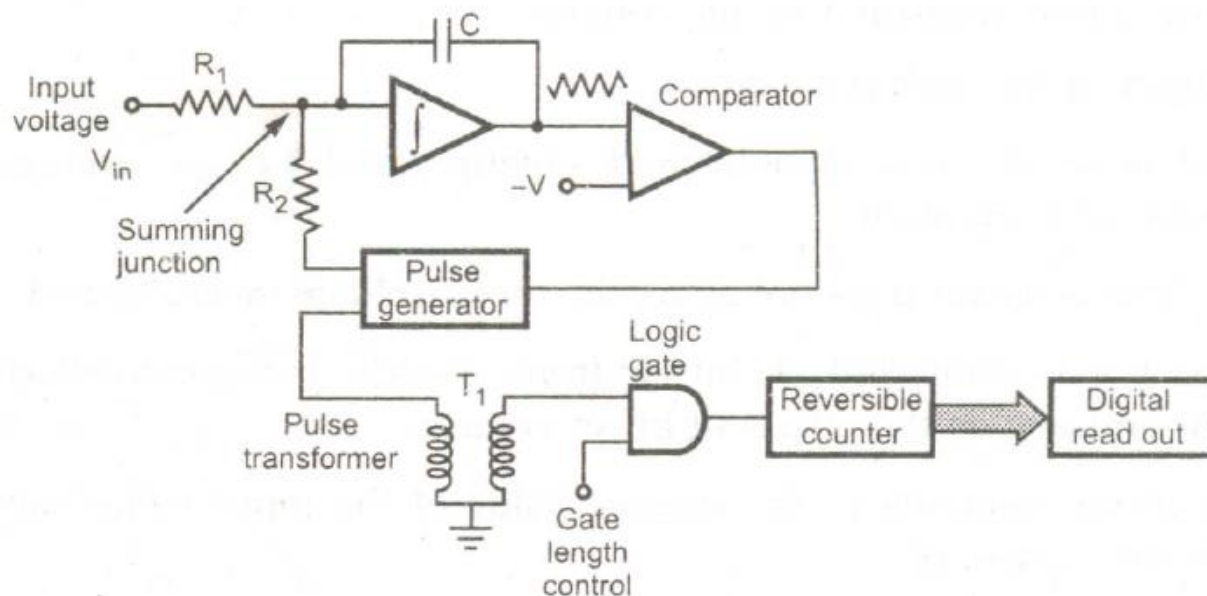

Initially output of an integrator is adjusted to zero volts. When the input voltage V_i is applied, the charging current V_i / R_j flows, which starts the charging of the capacitor C . This produces a ramp at the output. When input voltage is positive, the output ramp is negative going. This ramp is given as one input of a comparator. A $-V$ volts is given as a reference to the second input terminal of a comparator. The negative going ramp and $-V$ volts reference are compared by the comparator. When the ramp reaches to $-V$ volts, the comparator output changes its state. This

signal triggers the pulse generator. The function of the pulse generator is to produce a pulse of precision charge content. The polarity of this charge is opposite to that of capacitor charge. Thus the pulse generated by the pulse generator rapidly discharges the capacitor. Hence the output of the op-amp again becomes zero. This process continues so as to get a sawtooth waveform at the output of op-amp. The frequency of such waveform is directly proportional to the applied input voltage. Thus if the input voltage increases, the number of teeth per unit time in the sawtooth waveform also increases i.e. the frequency increases.

Each teeth produces a pulse at the output of the pulse generator so number of pulses is directly related to the number of teeth i.e. the frequency. These pulses are allowed to pass through the pulse transformer. These are applied at one input of the gate. Gate length control signal is applied at the other input. The gate length' may be 0.1 sec, 1sec, 20 msec etc. The gate remains open for this much time period.

The wavefoms of integrator output and output of a pulse generator are shown In the Fig

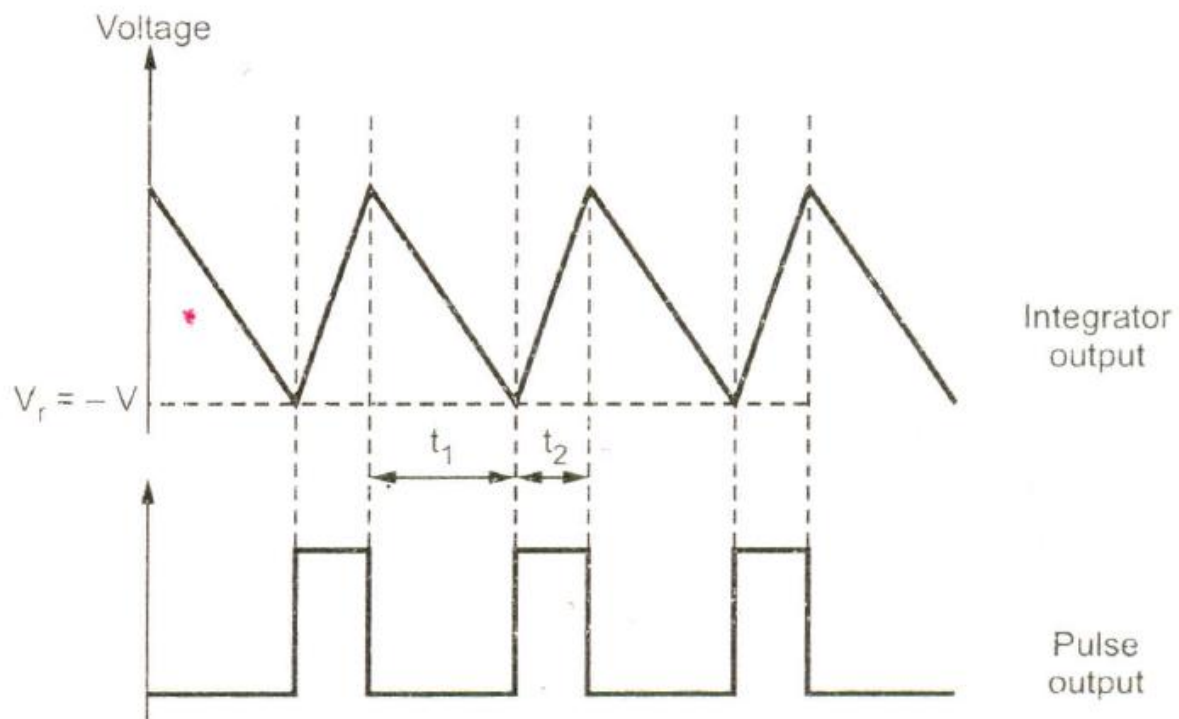

From the analysis of dual slope technique, we can write,

$$V_{in} = V_r \frac{t_2}{t_1}$$

But in this type, both V_1 and t_2 are constants.

$$K_2 = V_r t_2$$

$$V_{in} = K_2 \left(\frac{1}{t_1} \right) = K_2 (f_o)$$

Accuracy: The accuracy of voltage to frequency conversion technique depends on the magnitude and stability of the charge produced by the pulse generator. Thus the, accuracy depends on the precision of the charge feedback in every pulse and also on the linearity, between voltage and frequency.

To obtain the better accuracy the rate of pulses generated by the pulse generator is kept equal to,

- i) the voltage time integration of the input signal
- ii) the total voltage time areas of the feedback pulses.

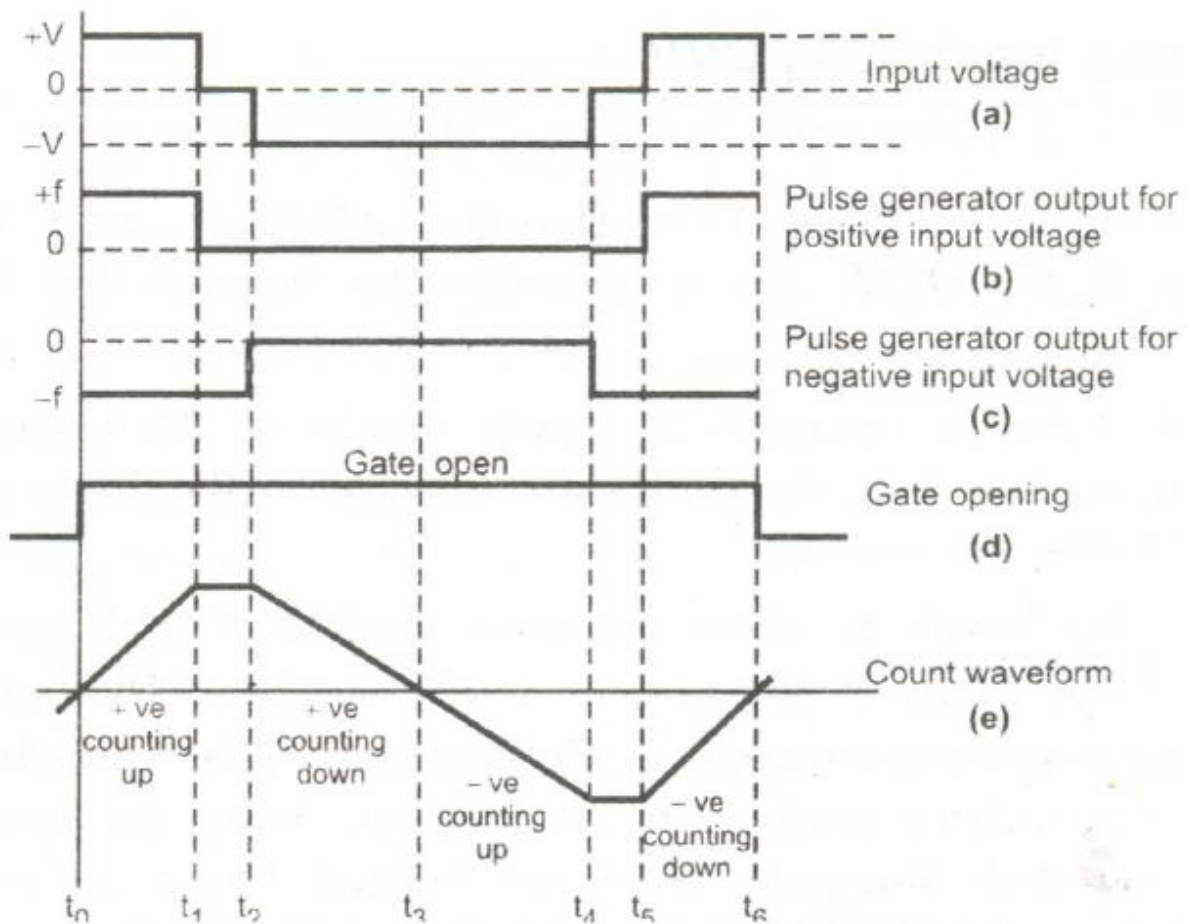

When input voltage polarity is positive i.e. for the periods t_0 (t_0 to t_1 and t_5 to t_6) the output of the pulse generator is high. For other time period it is low. This is shown in the Fig. When the input voltage polarity is negative i.e. for the period t_1 to t_4 the output of the pulse generator is high. This is due to other pulse generator used for the bipolar voltages. This is shown in the Fig. For the period t_0 to t_1 , it is positive counting up. For the period t_2 to t_3 it is positive counting down. For t_3 to t_4 negative counting up while for the period t_5 to t_6 , it is negative counting down.

Transfer characteristics : The transfer characteristics show the relation between the input voltage and the output frequency. This should be as linear as possible. It remains linear upto a frequency called **saturation frequency**. This is shown in the Fig. The slope of both the positive and negative voltage characteristics must be same.

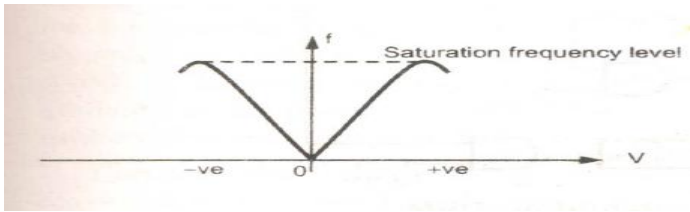

To increase the operating speed of this type of DVM, the upper frequency can be increased i.e. increasing $VI f$ conversion rate. But this results into reduced accuracy and design cost of such circuit is also very high. Hence another method in which 5 digit resolution is available, is used to increase the speed of operation. This is the modified version of $VI f$ integrating type DVM and is called interpolating integrating DVM.

Interpolating Integrating DVM:

The block diagram of interpolating integrating DVM is shown in the Fig.

This is a modified version of $VI f$ integrating DVM. A zero comparator is the additional circuitry in the DVM. The zero comparator ensures that the charge on the capacitor is zero. During first 20 msec, the operation is exactly similar to the normal $VI f$ integrating DVM. However during this time the pulses are directed to the 100 s decade. Here each pulse is equivalent to the 100 counts.

After 20 msec, the switch SI is moved from position 1 to 2 and V_{rer} of opposite polarity is offered. Some charge is still present on the capacitor. The opposite polarity V_{rer} helps to remove the remaining charge at a constant rate. When the charge reaches zero, the zero comparator provides a pulse to the control logic. When the switch is moved from position 1 to 2, at the same time gate G2 is also opened. Hence the pulses from 50 kHz oscillator can reach to Is decade. When the zero comparator provides a pulse, the gate G1 is closed. This completes the reading operation.

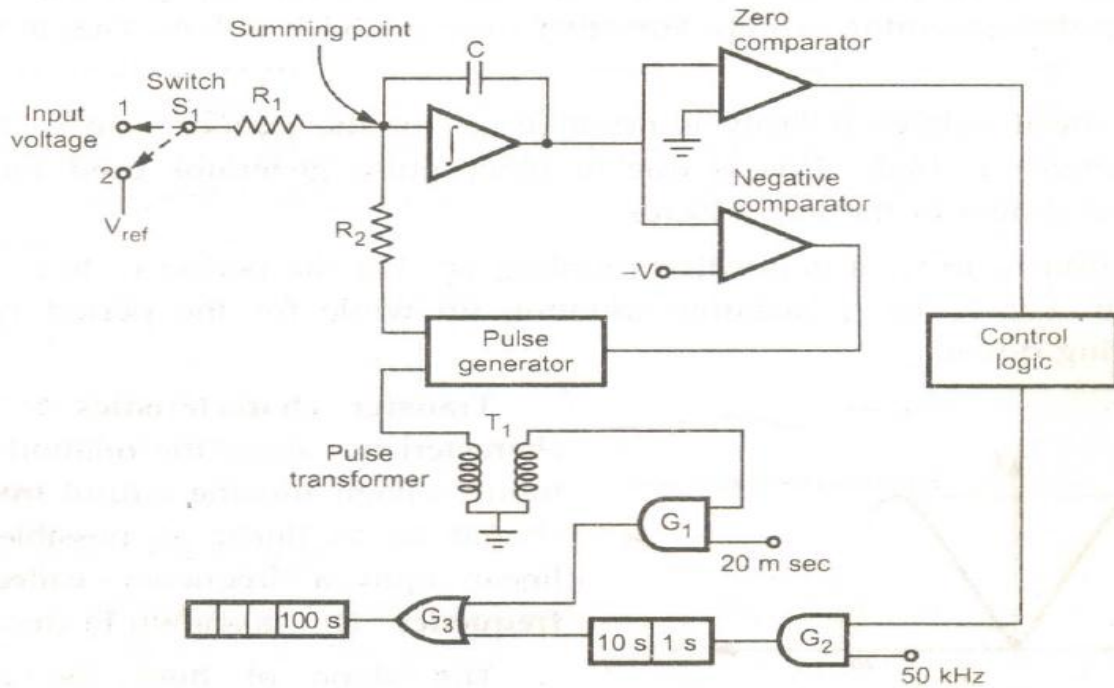

Successive approximation type DVM:

In successive approximation type DVM, the comparator compares the output of digital to analog converter with the unknown voltage. Accordingly, the comparator provides logic high or low signals. The digital to analog converter successively generates the set pattern of signals. The procedure continues till the output of the digital to analog converter becomes equal to the unknown voltage.

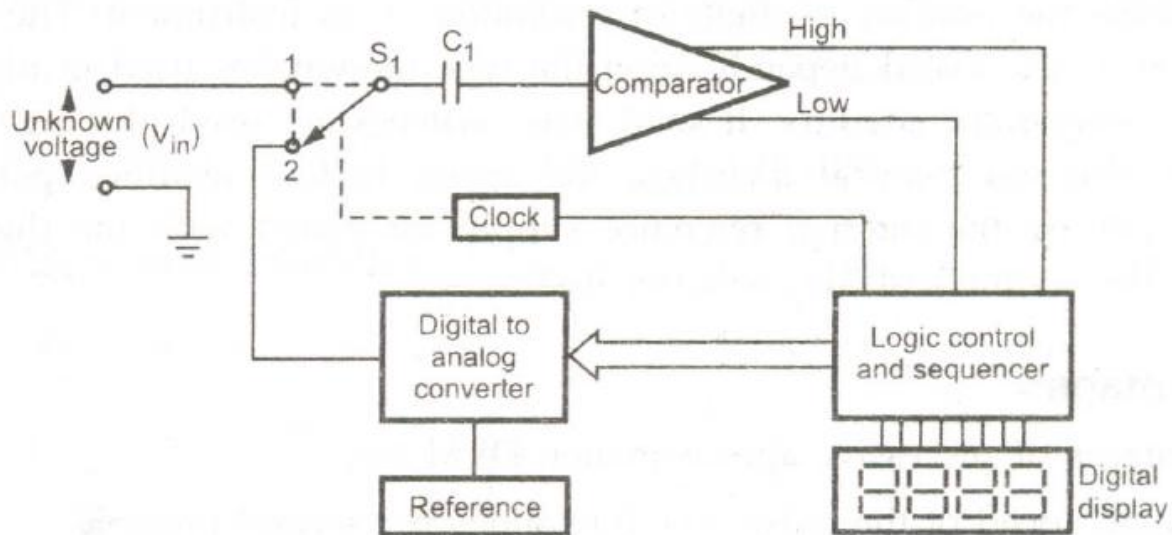

The capacitor is connected at the input of the comparator. The output of the digital to analog converter is compared with the unknown voltage, by the comparator. The output of the comparator is given to the logic control and sequencer. This unit generates the sequence of code which is applied to digital to analog converter. The position 2 of the switch 51 receives the output from digital to analog converter. The unknown voltage is available at the position 1 of the switch S1. The logic control also drives the clock which is used to alternate the switch S1 between the positions 1 and 2, as per the requirement.

Resolution and sensitivity:

If n is the number of full digits then the resolution of a DVM is given by,

$$R = \frac{1}{10^n}$$

where $R = \text{Resolution}$

Thus for 3 digit display, $n = 3$

$$\therefore R = \frac{1}{10^3} = 10^{-3} = 0.001 \text{ or } 0.1\%$$

The sensitivity is the smallest change in the input which a digital meter should be able to detect. Hence, it is the full scale value of the lowest range multiplied by the resolution of the meter.

$$S = (fs)_{\min} \times R$$

where $S = \text{Sensitivity}$

$(fs)_{\min} = \text{Full scale value on minimum range.}$

$R = \text{Resolution expressed as decimal.}$

Digital multimeters:

The digital multimeter is an instrument which is capable of measuring a.c. voltages, d.c. voltages, a.c. and d.c. currents and resistances *over* several ranges. The basic circuit of a digital multimeter is always a d.c. voltmeter as shown in the Fig

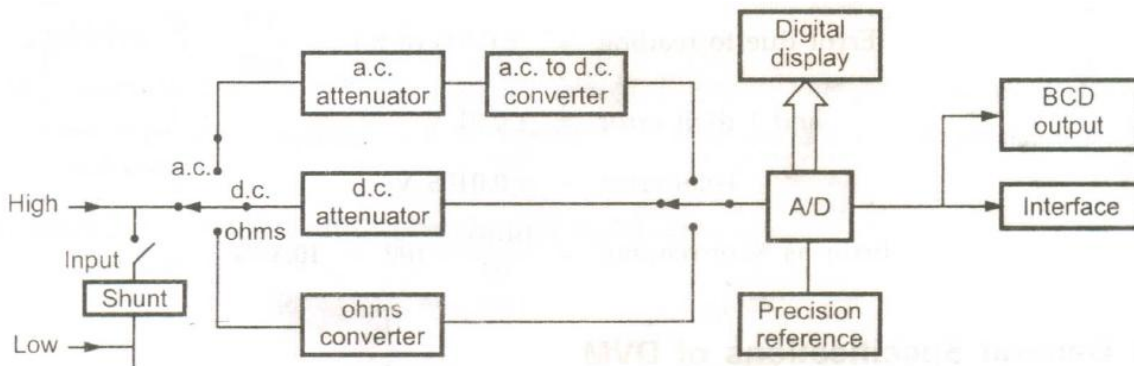

The current is converted to voltage by passing it through low shunt resistance. The a.c. quantities are converted to d.c. by employing various rectifier and filtering circuits. While for the resistance measurements the meter consists of a precision low current source that is applied across the unknown resistance while gives d.c. voltage. All the quantities are digitized using analog to digital converter and displayed in the digital form on the display.

The basic building blocks of digital multimeter are several A/D converters, counting circuitry and an attenuation circuit. Generally dual slope integration type ADC is preferred in the multimeters. The single attenuator circuit is used for both a.c. and d.c. measurements in many commercial multimeters. The block diagram of a digital multimeter is shown in the Fig.

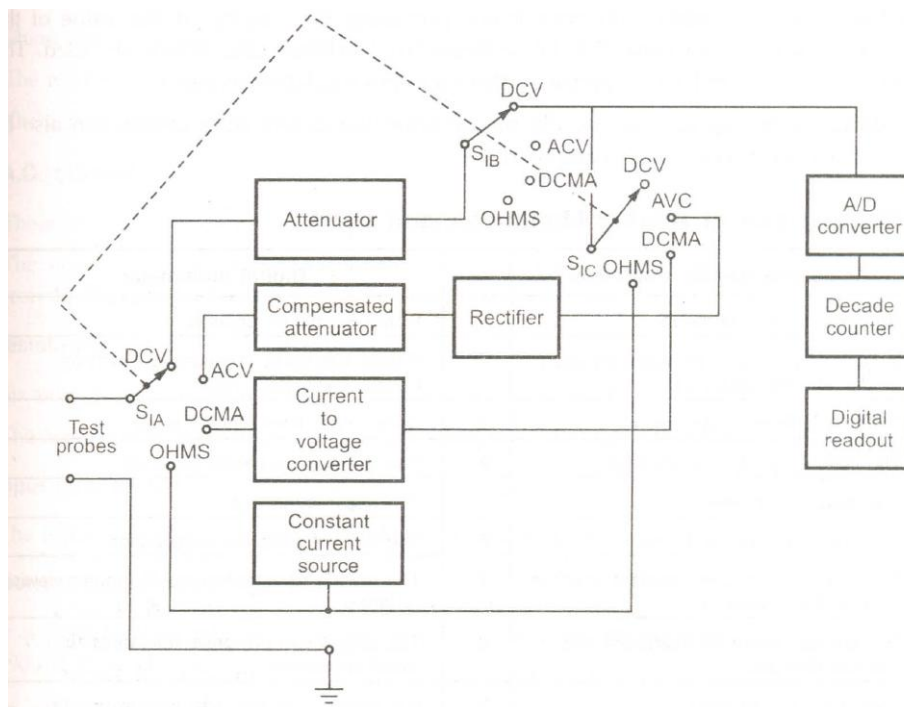

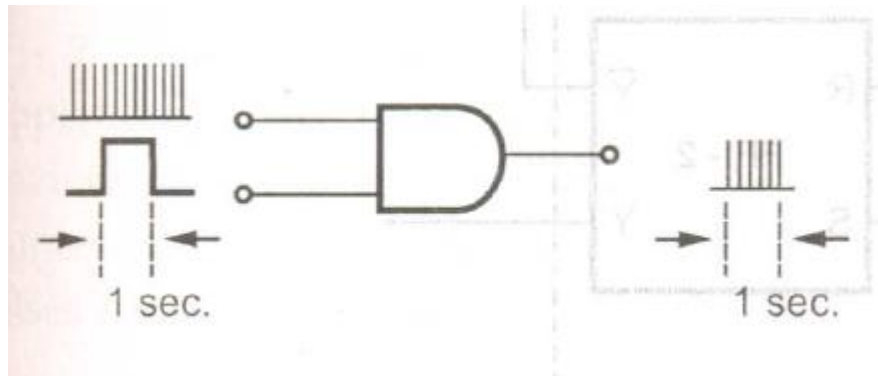
Digital Frequency meter:**Principle:**

The signal waveform whose frequency is to be measured is converted into trigger pulses and applied continuously to one terminal of an AND gate. To the other terminal of the gate, a pulse of 1 sec is applied as shown in the Fig. The number of pulses counted at the output terminal during period of 1 sec indicates the frequency.

The signal whose frequency is to be measured is converted to trigger pulses which is nothing but train of pulses with one pulse for each cycle of the signal. At the output terminal of AND gate, the number of pulses in a particular interval of time are counted using an electronic counter. Since each pulse represents the cycle of the unknown signal, the number of counts is a direct indication of the frequency of the signal which is unknown. Since electronic counter has a high speed of operation, high frequency signals can be measured.

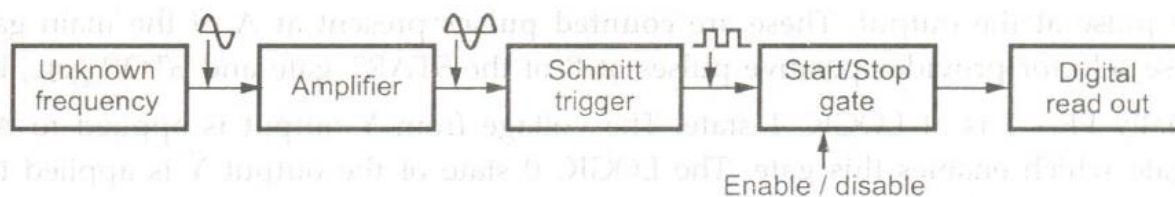
**Block diagram of digital frequency meter**

The signal waveform whose frequency is to be measured is first amplified. Then the amplified signal is applied to the schmitt trigger which converts input signal into a square wave with fast rise and fall times. This square wave is then differentiated and clipped. As a result, the output from the schmitt trigger is the train of pulses for each cycle of the signal. The output pulses from the schmitt trigger are fed to a START/STOP gate. When this gate is enabled, the input pulses pass through

this gate and are fed directly to the electronic counter, which counts the number of pulses. When this gate is disabled, the counter stops counting the incoming pulses. The counter displays the number of pulses that have passed through it in the time interval between start and stop. If this interval is known, the unknown frequency can be measured.

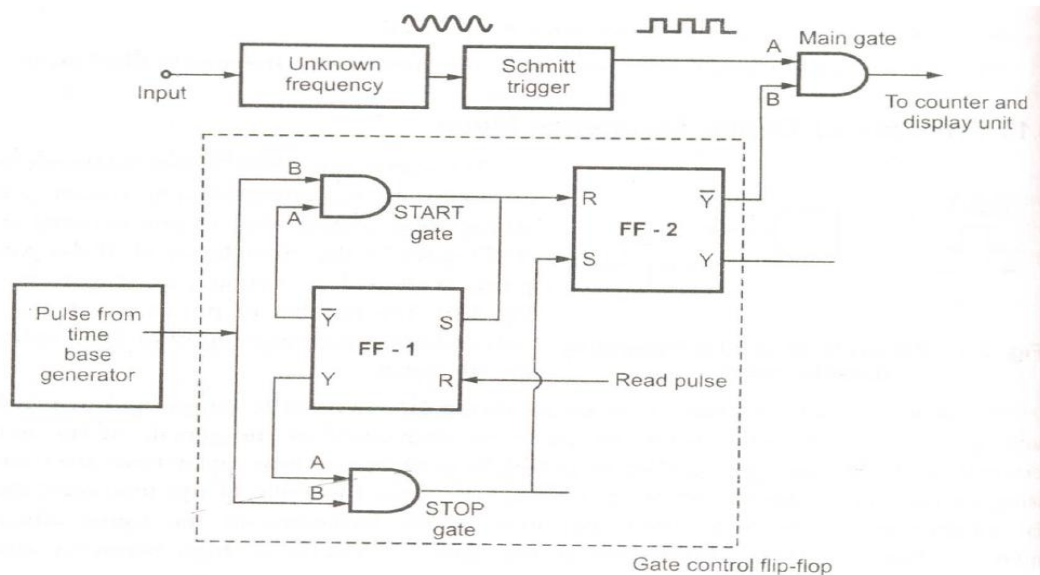

The output of unknown frequency is applied to the Schmitt trigger which produces positive pulse at the output. These are **counted pulses** present at A of the main gate. The time base selector provides positive pulses at B of the START gate and STOP gate, both. Initially FF - 1 is at LOGIC 1 state. The voltage from Y output is applied to A of the STOP gate which enables this gate. The LOGIC 0 state of the output Y is applied to input A of START gate which disables this gate. When STOP gate enables, positive pulses from the time base pass through STOP gate to S input of FF - 2, setting FF - 2 to LOGIC 1 state. The LOGIC 0 level of Y of FF - 2 is connected to B of main gate, which confirms that pulses from unknown frequency source can't pass through the main gate. By applying a positive pulse to R input of FF - 1, the operation is started. This changes states of the FF - 1 to Y = 1 and $\bar{Y} = 0$. Due to this, STOP gate gets disabled, while START gate gets enabled. The same pulse is simultaneously applied to all decade counters to reset all of them, to start new counting.

With the next pulse from the time base passes through START gate resetting FF - 2 and it changes state from LOGIC 0 to LOGIC 1. As Y changes from 0 to 1, the gating signal is applied to input B of the main gate which enables the main gate.

Now the pulses from source can pass, through the main gate to the counter. The counter counts pulses. The state of FF - 1 changes from a to 1 by applying same pulse from START gate to S input of FF - 1. Now the START gate gets disabled, while STOP gate gets enabled. It is important that the pulses of unknown frequency pass through the main gate to counter till the main gate is enabled.

The next pulse from the time base generator passes through STOP Gate to S input of FF - 2. This sets output back to 1 and $Y = 0$. Now main gate gets disabled. The source supplying pulses of unknown frequency gets disconnected. In between this pulse and previous pulse from the time base selector, the number of pulses are counted by the counter. When the interval of time between two pulses is 1 second, then the count of pulses indicates the frequency of the unknown frequency source.

1. Input signal conditioning circuit :

In this circuit, an amplifier and schmitt trigger are included. The threshold voltage of the schmitt trigger can be controlled by sensitivity control on the control panel. First of all the input signal of unknown frequency is fed into input signal conditioning circuit. There the signal is amplified and then it is converted into square wave by schmitt trigger circuit.

2. Time base generator:

The crystal oscillator produces a signal of 1 MHz or 100 MHz depending upon the requirement. In general, the accuracy of the digital frequency counter depends on the accuracy of the time base signals produced, thus the temperature compensated crystal oscillator is used. The output of the oscillator is passed through another schmitt trigger circuit producing square wave output. Then it is fed to frequency dividers connected in cascade. Thus a train of pulses are obtained after each frequency divider section. Using time base selector switch the Gate Time can be adjusted. The gating circuit consists of AND gate. When the enable signal is provided to the AND gate, it allows a train of pulses to pass through the gate for the time period selected by the time base circuit. The pulses are counted and then the second pulse generated from the time base generator disables AND gate and thus closes it.

In this unit, decade counters are connected in the cascade. The output of the AND gate is connected to the clock input of the first decade counter. Then the output of this counter is connected to the clock input of next and so on. Using these counters the number of pulses are counted and are

displayed by the display unit. As the number of pulses counted are proportional to the input signal frequency, the final display is proportional to the unknown frequency of the input signal.

Period measurement:

Using the frequency counter, the period measurement is possible. As we know, time period $T = 1/f$. If the frequency to be measured is low, then the accuracy of the frequency counter decreases as less number of pulses are connected to the gating circuit.

Thus in low frequency region it is better to measure period rather than frequency. The block diagram of the period mode of the digital frequency counter is as shown in the Fig

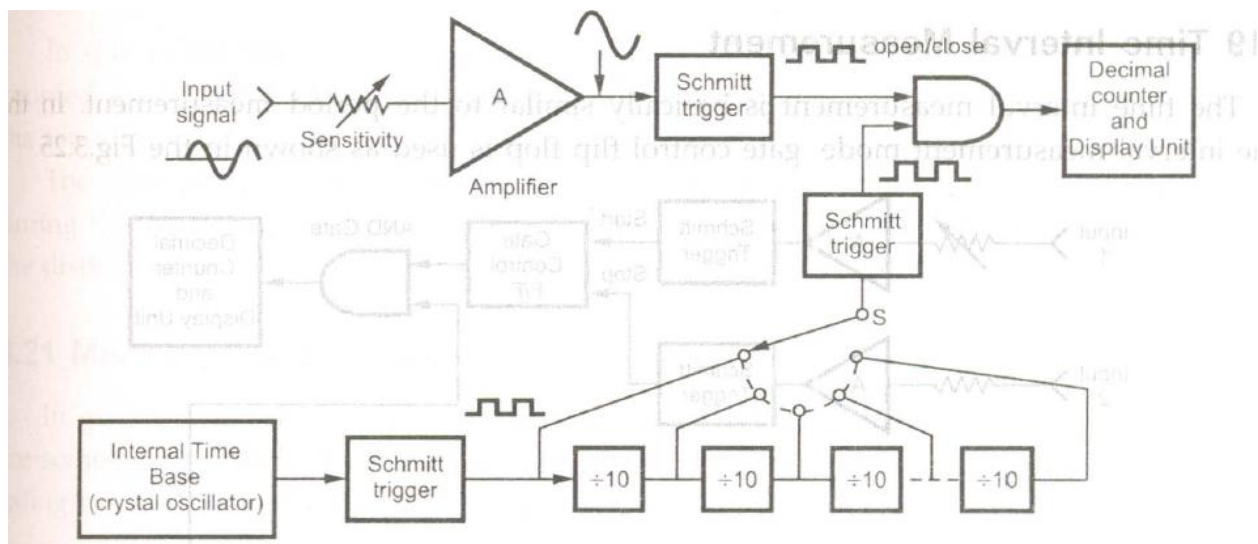

The main difference in the frequency mode and period mode of the digital frequency counter is that the unknown input signal controls the gate time of the gating circuit while the time base frequency is counted in the decade counter assembly. Note that in the period mode, the input signal conditioning circuit produces a train of pulses. So the positive going zero crossing pulses are used as trigger pulses for opening and closing of AND gate in the gating circuit. The main advantage of the period mode is that the accuracy is greater for the low frequency input signals.

Time interval measurement:

The time interval measurement is basically similar to the period measurement. In the time interval measurement mode, gate control flip flop is used as shown in the Fig

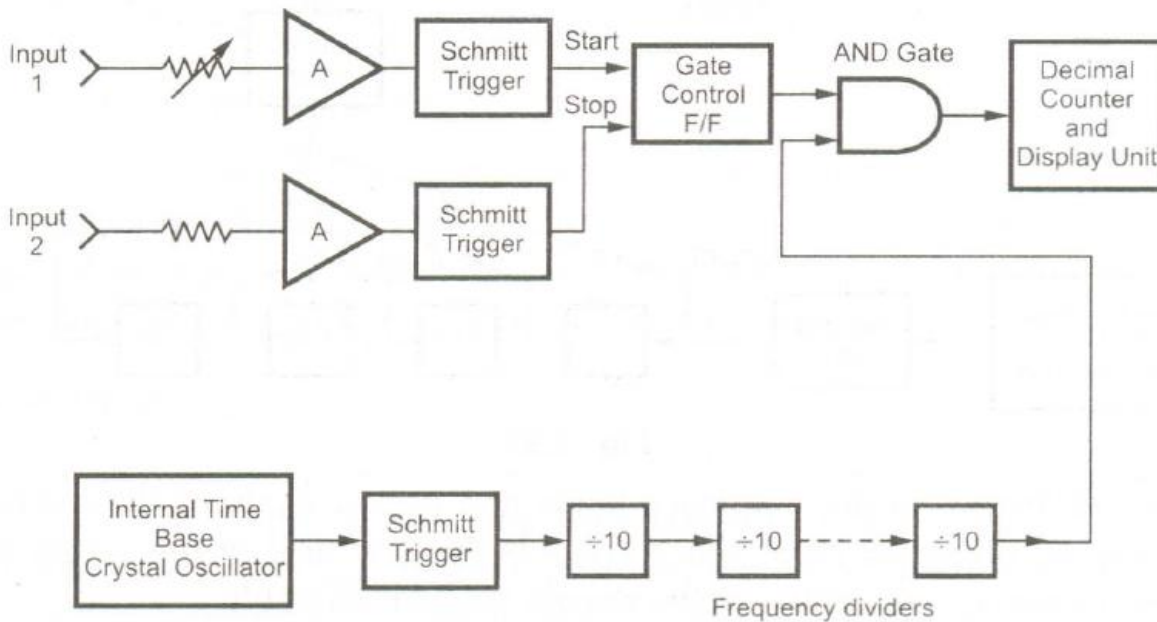

In this measurement mode, two inputs are used to start and stop the counting. Here similar to the period measurement, the internal frequency pulses generated by time base generator circuit are counted. The start and stop signals are derived from two inputs. The AND gate is enabled with the external input 1 applied. The counting of the pulses starts at this instant. The AND gate is disabled with the input 2 applied. Thus pulses are counted in the time interval which is proportional to the time interval between application of inputs 1 and 2.

Frequency ratio measurement:

By using the frequency counter, the ratio of two frequencies can be measured. It is again similar to period measurement. The block diagram is as shown in the Fig.

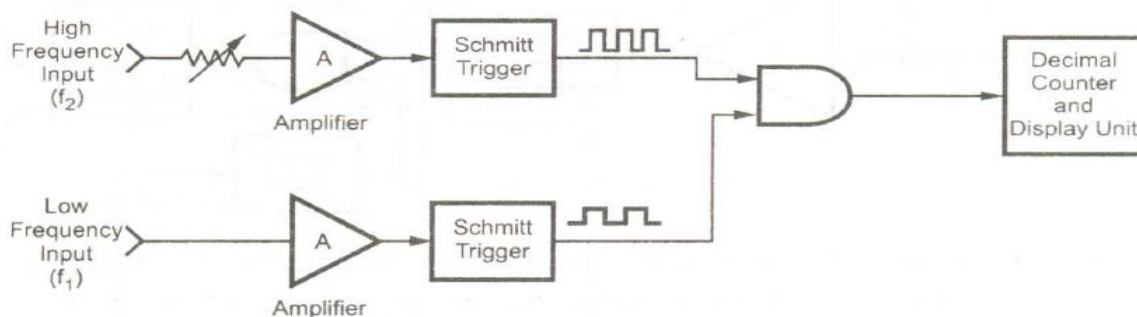

In this mode, the low frequency signal is used as gating signal, while the pulses are counted for the high frequency signal. Hence it is clear that the low frequency represents the time base.

The number of pulses corresponding to the high frequency signal f_2 are counted during the period of the low frequency signal f_1 , by the decade counters and displayed by the display unit.

Recommended question:

1. State the advantages of digital voltmeters over other voltmeters.
2. Explain with neat circuit diagrams the working of the following digital voltmeter. [jan 05,07,09 jul 06,08]
 - I) Successive approximation type DVM
 - ii) Linear ramp type DVM
 - iii) Staircase ramp type DVM
 - iv) Voltage to frequency converter type integrating DVM
 - v) Dual slope integrating type DVM
3. Compare the linear and staircase ramp techniques.
4. Why reversible counter is used in V- f converter type DVM?
5. Explain the following terms as applied to digital displays:
 - i) Resolution ii) Sensitivity iii) Accuracy specifications
6. Compare analog multimeter with digital multimeter (DMV).
7. Draw and explain the basic block diagram of DMM. [jan 09]
8. State the various specifications of DMM. [jul 09]
9. A $3\frac{1}{2}$ digital voltmeter is used for measuring voltage
 - i) Find its resolution [jan 05]
 - ii) How would the voltage of 14.53 V be displayed on 10 V scale?
 - iii) How would the reading of 14.53 V be displayed on 100 V scale?
10. The lowest resolution of a 4-digit DVM is 10 mV full scale. What is its sensitivity?
11. Explain how frequency is measured using the digital frequency counter.
12. Explain how digital frequency counter is used to measure,
 - (i) frequency, (ii) period, (iii) time interval, (iv) ratio of frequencies.

Unit:III

Hrs: 06

Syllabus:

Oscilloscopes

Introduction, Basic principles, CRT features, Block diagram and working of each block, Typical CRT connections, Dual beam and dual trace CROs, Electronic switch(Text 1: 7.1 to 7.9, 7.12, 7.14 to 7.16)

Recommended readings:

1. “Electronic Instrumentation”, H. S. Kalsi, TMH, 2004
2. “Electronic Instrumentation and Measurements”, David A Bell, PHI / Pearson Education, 2006.

Unit 3:**Oscilloscopes****06 Hours****Introduction:**

In studying the various electronic, electrical networks and systems, signals which are functions of time, are often encountered. Such signals may be periodic or non periodic in nature. The device which allows, the amplitude of such signals, to be displayed primarily as " function of time, is called **cathode ray** oscilloscope, commonly known as C.R.O. The CR.O gives the visual representation of the time varying signals. The oscilloscope has become an universal instrument and is probably most versatile tool for the development of electronic circuits and systems. It is an integral part of electronic laboratories.

The oscilloscope is, in fact, a voltmeter. Instead of the mechanical deflection of a metallic pointer as used in the normal voltmeters, the oscilloscope uses the movement of an electron beam against a fluorescent screen, which produces the movement of a visible spot. The movement of such spot on the screen is proportional to the varying magnitude of the signal, which is under measurement.

Basic Principle:

The electron beam can be deflected in two directions : the horizontal or x-direction and the vertical or y-direction. Thus an electron beam producing a spot can be used to produce two dimensional displays, Thus CRO. can be regarded as a fast x-y plotter. The x-axis and y-axis can be used to study the variation of one voltage as a function of another. Typically the x-axis of the oscilloscope represents the time while the y-axis represents variation of the input voltage signal. Thus if the input voltage signal applied to the y-axis of CRO. is sinusoidally varying and if x-axis represents the time axis, then the spot moves sinusoidally, and the familiar sinusoidal waveform can be seen on the screen of the oscilloscope. The oscilloscope is so fast device that it can display the periodic signals whose time period is as small as microseconds and even nanoseconds. The CRO. Basically operates on voltages, but it is possible to convert current, pressure, strain, acceleration and other physical quantities into the voltage using transducers and obtain their visual representations on the CRO.

Cathode Ray Tube (CRT):

The cathode ray tube (CRT) is the heart of the CR.O. the CRT generates the electron

beam, accelerates the beam, deflects the beam and also has a screen where beam becomes visible, as a spot. The main parts of the CRT are:

- i) Electron gun
- ii) Deflection system
- iii) Fluorescent screen
- iv) Glass tube or envelope
- v) Base

A schematic diagram of CRT, showing its structure and main components is shown in the Fig.

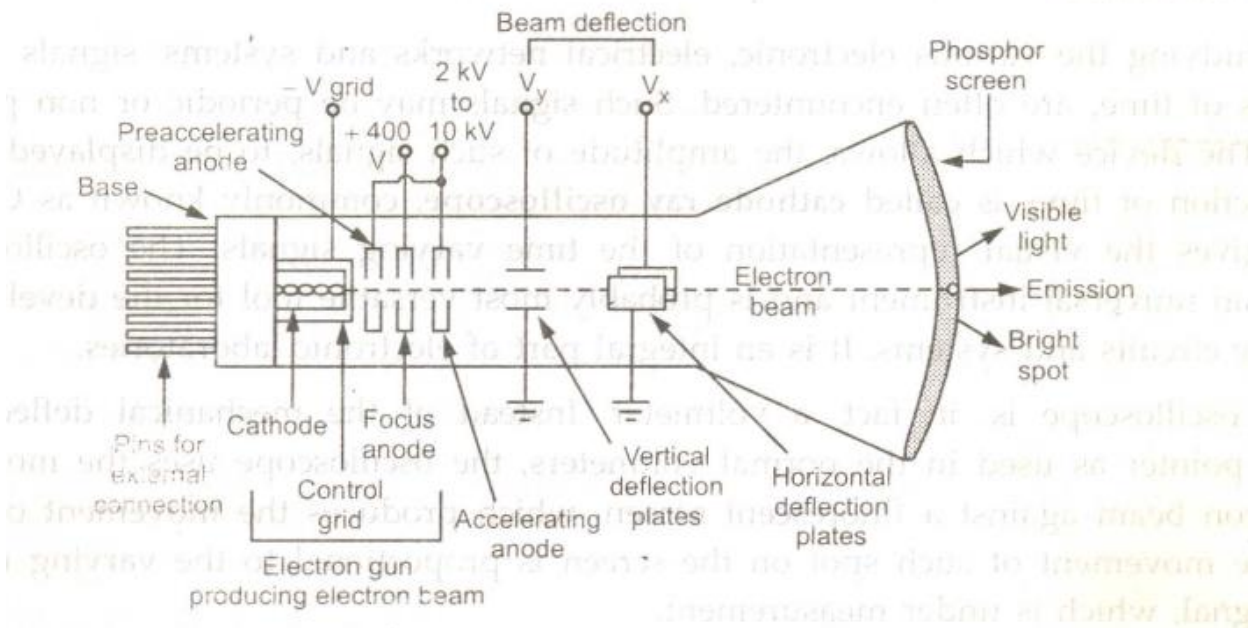

Electron Gun:

The electron gun section of the cathode ray tube provides a sharply focused electron beam directed towards the fluorescent-coated screen. This section starts from the thermally heated cathode, limiting the electrons. The control grid is given a negative potential with respect to cathode dc. This grid controls the number of electrons in the beam, going to the screen.

The momentum of the electrons (their number \times their speed) determines the intensity, or brightness, of the light emitted from the fluorescent screen due to the electron bombardment. The light emitted is usually of the green colour. Because the electrons are negatively charged, a repulsive force is created by applying a negative voltage to the control grid (in CRT, voltages applied to various grids are stated with respect to cathode, which is taken as common point). This negative control voltage can be made variable.

Deflection System:

When the electron beam is accelerated it passes through the deflection system, with which beam can be positioned anywhere on the screen. The deflection system of the cathode-ray-tube consists of two pairs of parallel plates, referred to as the vertical and horizontal deflection plates. One of the plates' in each set is connected to ground (0 V), To the other plate of each set, the external deflection voltage is applied through an internal adjustable gain amplifier stage, To apply the deflection voltage externally, an external terminal, called the Y input or the X input, is available.

As shown in the Fig. , the electron beam passes through these plates. A positive voltage applied to the Y input terminal (V_y) Causes the beam to deflect vertically upward due to the attraction forces, while a negative voltage applied to. the Y input terminal will cause the electron beam to deflect vertically downward, due to the repulsion forces. When the voltages are applied simultaneously to vertical and horizontal deflecting plates, the electron beam is deflected due to the resultant-of these two voltages.

Fluorescent Screen:

The light produced by the screen does not disappear immediately when bombardment by electrons ceases, i.e., when the signal becomes zero. The time period for which the trace remains on the screen after the signal becomes zero is known as "persistence". The persistence may be μs short as a few microsecond, or as long as tens of seconds ~en minutes.

Long persistence traces are used in the study.. of transients. Long persistence helps in the study of transients since the trace is still seen on the screen after the transient has disappeared.

Phosphor screen characteristics:

Many phosphor materials having different excitation times and colours as well as different phosphorescence times are available. The type P1, P2, P11 or P31 are the short persistence phosphors and are used for the general purpose oscilloscope

Medical oscilloscopes require a longer phosphor decay and hence phosphors like P7 and P39 are preferred for such applications. Very slow displays like radar require long persistence phosphors to maintain sufficient flicker free picture. Such phosphors are P19, P26 and, P33.

The phosphors P19, P26, P33 have low burn resistance. The phosphors P1, P2, P4, P7, P11 have medium burn resistance while P1S, P3I have high burn resistance.

Block diagram of simple oscilloscope:

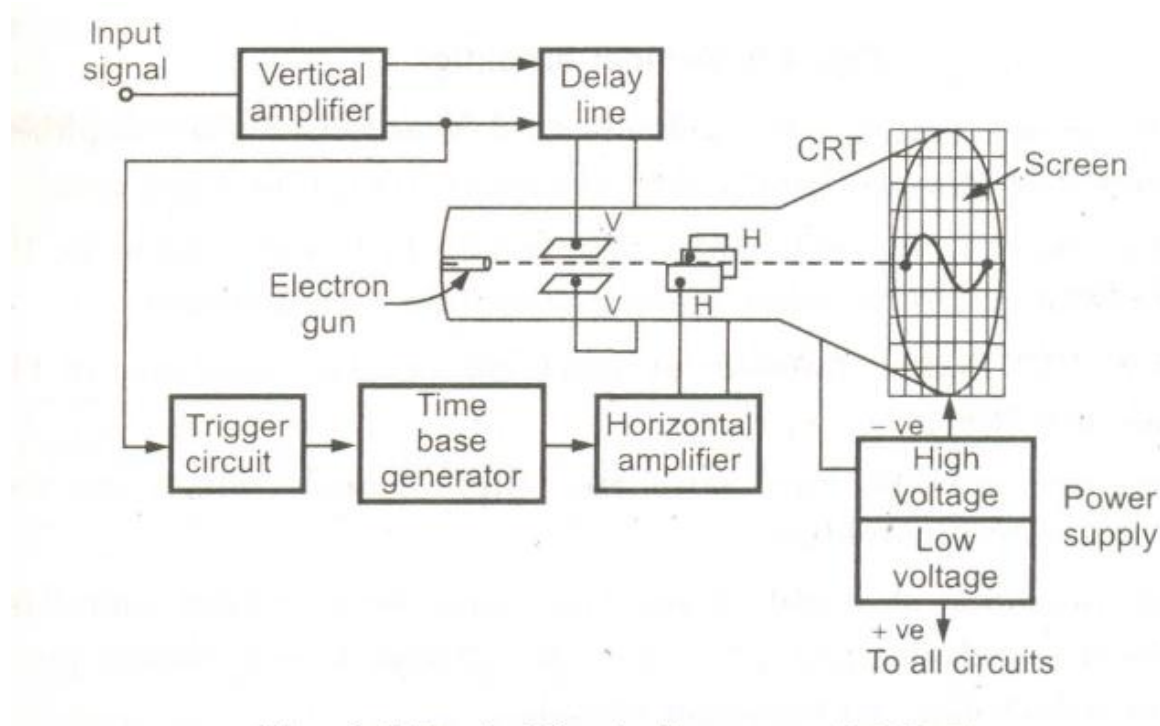

CRT:

This is the cathode ray tube which is the heart of C.R.O. It is used to emit the electrons required to strike the phosphor screen to produce the spot for the visual display of the signals.

Vertical Amplifier:

The input signals are generally not strong to provide the measurable deflection on the screen. Hence the vertical amplifier stage is used to amplify the input signals. The amplifier stages used are generally wide band amplifiers so as to pass faithfully the entire band of frequencies to be measured. Similarly it contains the attenuator stages as well. The attenuators are used when very high voltage signals are to be examined, to bring the signals within the proper range of operation.

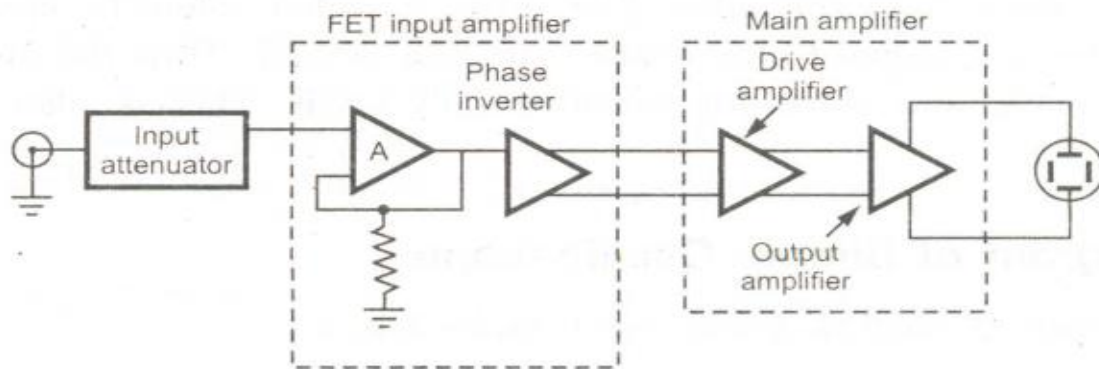

It consists of several stages with overall fixed sensitivity. The amplifier can be designed for stability and required bandwidth very easily due to the fixed gain. The input stage consists of an attenuator followed by FET source follower. It has very high input impedance required to isolate the amplifier from the attenuator. It is followed by BJT emitter follower to match the output impedance of FET output with input of phase inverter. The phase inverter provides two antiphase output signals which are required to operate the push pull output amplifier. The push pull operation has advantages like better hum voltage cancellation, even harmonic suppression especially large 2nd harmonic, greater power output per tube and reduced number of defocusing and nonlinear effects.

Delay line:

The delay line is used to delay the signal for some time in the vertical sections. When the delay line is not used, the part of the signal gets lost. Thus the input signal is not applied directly to the vertical plates but is delayed by some time using a delay line circuit as shown in the Fig.

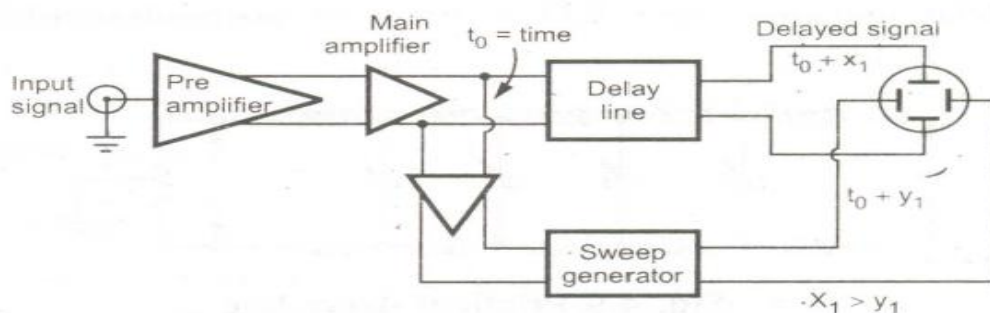

If the trigger pulse is picked off at a time $t = t_0$ after the signal has passed through the main amplifier then signal is delayed by X_1 nanoseconds while sweep takes Y_1 nanoseconds to reach.

The design of delay line is such that the delay time XI is higher than the time YI . Generally XI is 200. nsec while YI is 80 ns, thus the sweep starts well in time and no part of the signal is lost.

There are two types of delay lines used in C.R.O. which are:

- i) Lumped parameter delay line
- ii) Distributed parameter delay line

Trigger circuit:

It is necessary that horizontal deflection starts at the same point of the input vertical signal, each time it sweeps. Hence to synchronize horizontal deflection with vertical deflection a synchronizing or triggering circuit is used. It converts the incoming signal into the triggering pulses, which are used for the synchronization.

Time base generator:

The time base generator is used to generate the sawtooth voltage, required to deflect the beam in the horizontal section. This voltage deflects the spot at a constant time dependent rate. Thus the x-axis' on the screen can be represented as time, which, helps to display and analyse the time varying signals.

Dual Beam Oscilloscope:

Another method of studying two voltages simultaneously on the screen is to use a special cathode ray tube having two separate electron guns generating two separate beams. Each electron beam has its own vertical deflection plates.

But the two beams are deflected horizontally by the common set of horizontal plates. The time base circuit may be same or different. Such an oscilloscope is called **Dual Beam Oscilloscope**.

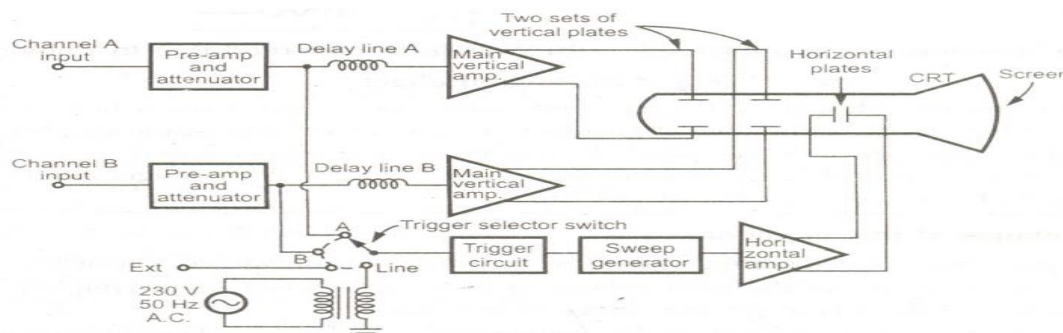

The oscilloscope has two vertical deflection plates and two separate channels A and B for the two separate input signals. Each channel consists of a preamplifier and an attenuator. A delay line, main vertical amplifier and a set of vertical deflection plates together forms a single channel. There

is a single set of horizontal plates and single time base circuit. The sweep generator drives the horizontal amplifier which in turn drives the plates. The horizontal plates sweep both the beams across the screen at the same rate. The sweep generator can be triggered internally by the channel A signal or channel B signal. Similarly it can also be triggered from an external signal or line frequency signal. This is possible with the help of trigger selector switch, a front panel control. Such an oscilloscope may have separate timebase circuit for separate channel. This allows different sweep rates for the two channels but increases the size and weight of the oscilloscope.

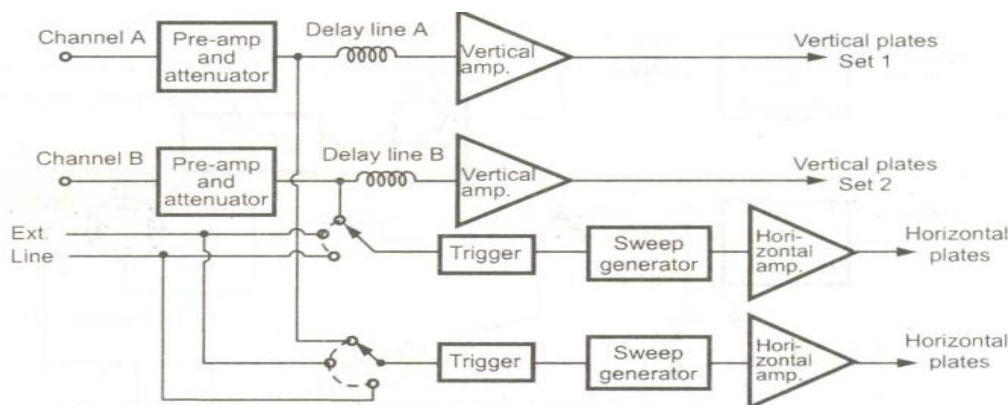

Dual beam CRO with separate time bases

Multiple beam oscilloscopes:

Multiple beam oscilloscope has a single tube but several beam producing systems inside. Each system has separate vertical deflecting pair of plates and generally (1 common time base system.

The triggering can be done internally using either of the multiple inputs or externally by an external signal or line voltages.

Dual trace oscilloscope:

The comparison of two or more voltages is very much necessary in the analysis and study of many electronic circuits and systems. This is possible by using more than one oscilloscope but in such a case it is difficult to trigger the sweep of each oscilloscope precisely at the same time. A common and less costly method to solve this problem is to use dual trace or multitrace oscilloscopes. In this method, the same electron beam is used to generate two traces which can be deflected from two

independent vertical sources. The methods are used to generate two independent traces which the alternate sweep method and other is chop method.

The block diagram of dual trace oscilloscope is shown in the Fig

There are two separate vertical input channels A and B. A separate preamplifier and -attenuator stage exists for each channel. Hence amplitude of each input can be individually controlled. After preamplifier stage, both the signals are fed to an electronic switch. The switch has an ability to pass one channel at a time via delay line to the vertical amplifier. The time base circuit uses a trigger selector switch 52 which allows the circuit to be triggered on either A or B channel, on line frequency or on an external signal. The horizontal amplifier is fed from the sweep generator or the B channel via switch 51 and 51. The X-Y mode means, the oscilloscope operates from channel A as the vertical signal and the channel B as the horizontal signal. Thus in this mode very accurate X-Y measurements can be done.

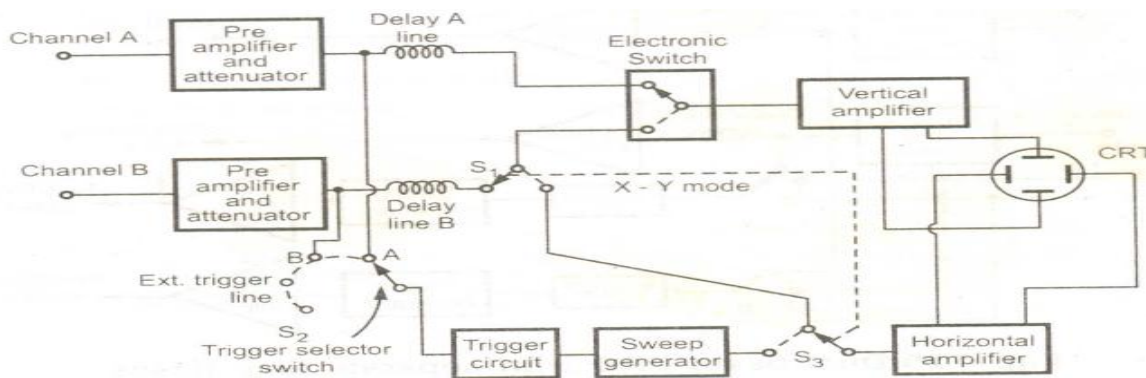

Recommended questions:

1. State the various characteristics of P31 phosphor .

.J. Draw the block diagram of general purpose CRO. Explain the functions of various blocks..

2. Draw and Explain the block diagram of the vertical amplifier used in oscilloscopes.

3. Explain the functions of delay lines in oscilloscopes. Which are the two types of delay lines?

4. State and Explain various front panel controls of a Simple CRO. [all years asked till now]

5. Explain the following modes of operation of time base generator [jan 06, 05, jul 07]

i) Free run mode

ii) Auto mode

iii) single sweep mode

6. Draw the block diagram of a trigger generator. Explain the various controls associated With It.
7. What is the use of ACs and ACF controls?
8. Which are the typical trigger sources 7 Explain their siglllficol/cl'.
16. Explain the use of following controls
I) INT II) EXT III) LINE

Unit:IV

Hrs: 06

Syllabus:

Special Oscilloscopes

Delayed time-base oscilloscopes, Analog storage, Sampling and Digital storage oscilloscopes
(Text 2: 10.1 to 10.4)

Recommended readings:

1. “Electronic Instrumentation”, H. S. Kalsi, TMH, 2004
2. “Electronic Instrumentation and Measurements”, David A Bell, PHI / Pearson Education, 2006.

Unit 4:**Special Oscilloscopes****06 Hours****Delayed time base oscilloscope:**

In a conventional oscilloscope, the signal to the vertical plates is delayed by some time, using a delay line circuit. The waveform before the delay circuit is used to trigger the time base. This allows the study of all the leading or lagging edges of a pulse type waveform. This is shown in the Fig

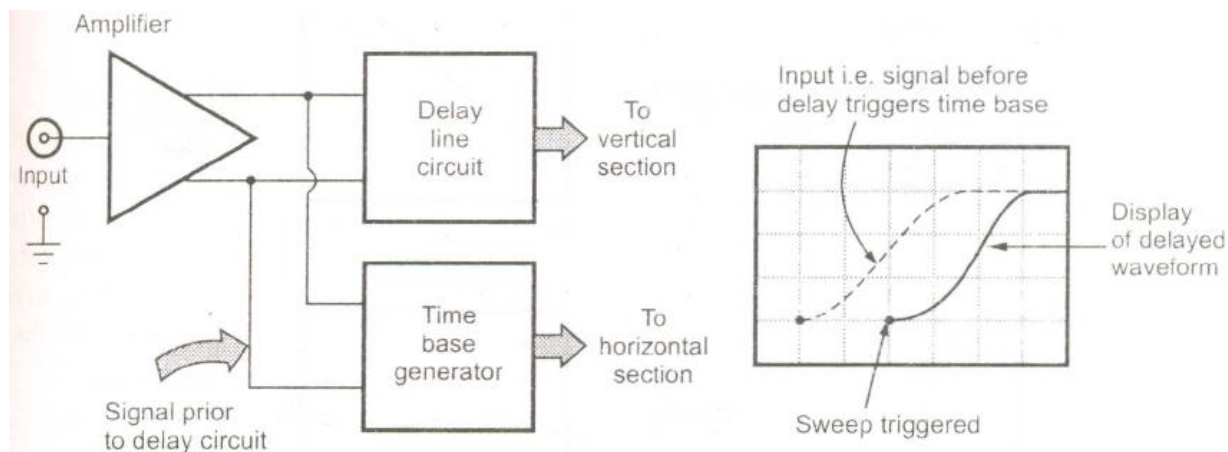

Due to triggering of time base by input signal, sweep starts well in time and when input appears at vertical sections, the sweep is triggered and delayed waveform is displayed. The delay ensures that no part of the waveform gets lost.

In a delayed time base oscilloscope, a variable time delay circuit is used in the basic time base circuit. This allows the triggering of sweep time after the delay time. Thus the delay time is variable. This time is denoted as t_d . After this, the sweep is triggered for the time t_s . Then the portion of the waveform for the time t_x gets expanded on the complete oscilloscope screen, for the detail study.

If input is pulse waveform and leading edge is used to trigger the delay time, then leading edge can be displayed to fill the entire oscilloscope screen. This is shown in the Fig (a). Similarly if the lagging edge is used to trigger the delay time then leading edge can be displayed on the entire screen for the time t_x . This is shown in the Fig.(b). If the time delay is perfectly adjusted, then any portion of the waveform can be extended to fill the entire screen. This is shown in the Fig. (c).

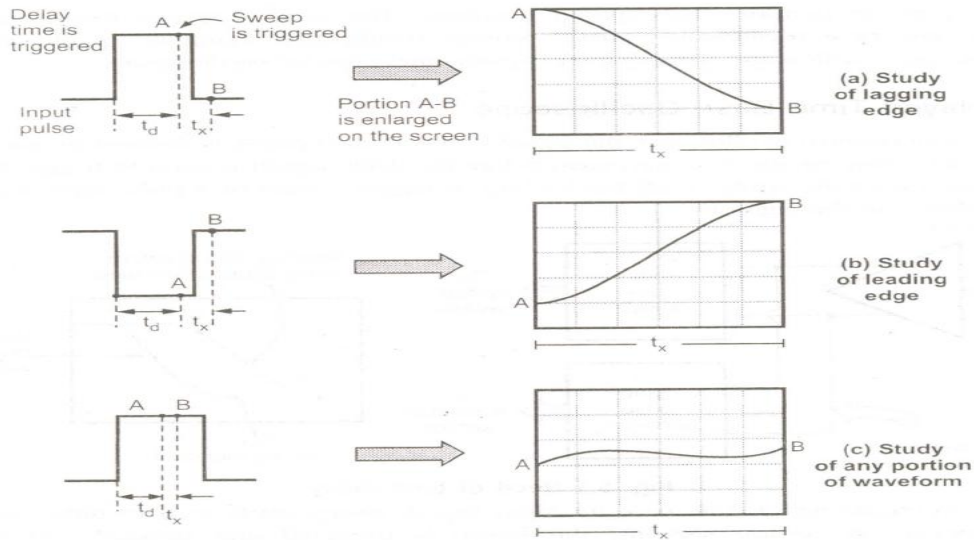

Use of additional time delay

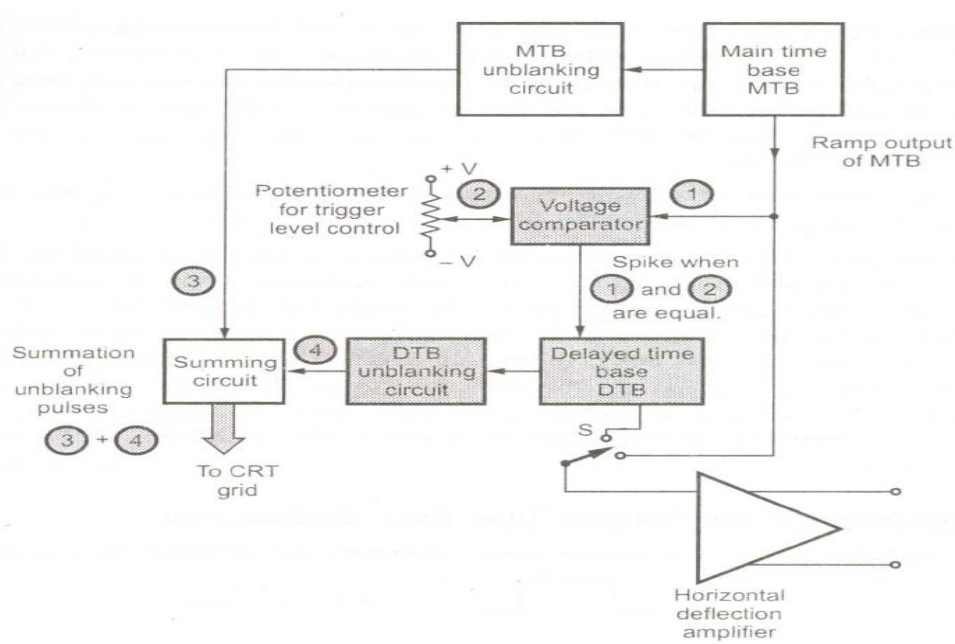

Delayed time base oscilloscope

The normal time base circuit is main time base (MTB) circuit which functions same as c1 conventional oscilloscope. The function of MTB blanking circuit is to produce an unblanking pulse which is applied to CRT grid to turn on an electron beam in the CRT, during the display

sweep time. The ramp output of MTB is given to the horizontal deflection amplifier via switch S. It is also given as one input to the voltage comparator. The other input to the voltage comparator is derived from the potentiometer whose level is adjustable.

The unblanking pulses from MTB and DTB are added by **summing circuit** and given to the CRT grid. The unblanking pulse of MTB produces a trace of uniform intensity. But during ramp time of DTB, the addition of two pulses decides the intensity of the trace on the screen. Hence during DTB time, the voltage applied to CRT grid is almost twice than the voltage corresponding to MTB time. This increases the brightness of the displayed waveform for the DTB time.

When the part of the waveform to be brightened is identified, then the DTB ramp output is connected to the input of the horizontal deflection amplifier through switch S. The DTB ramp time is much smaller than MTB period but its amplitude (- V to + V) is same as MTB ramp. Hence it causes the oscilloscope electron beam to be deflected from one side of the screen to the other, during short DTB time. By adjusting DTB time/ div control, the brightened portion can be extended, so as to fill the entire screen of the oscilloscope. The horizontal deflection starts only after the delay time t_d from the beginning of the MTB sweep. Thus very small part of the waveform can be extended on the entire screen.

Waveforms of the Delayed Time Base Oscilloscope

The waveforms of the delayed time base oscilloscope are shown **in** the Fig

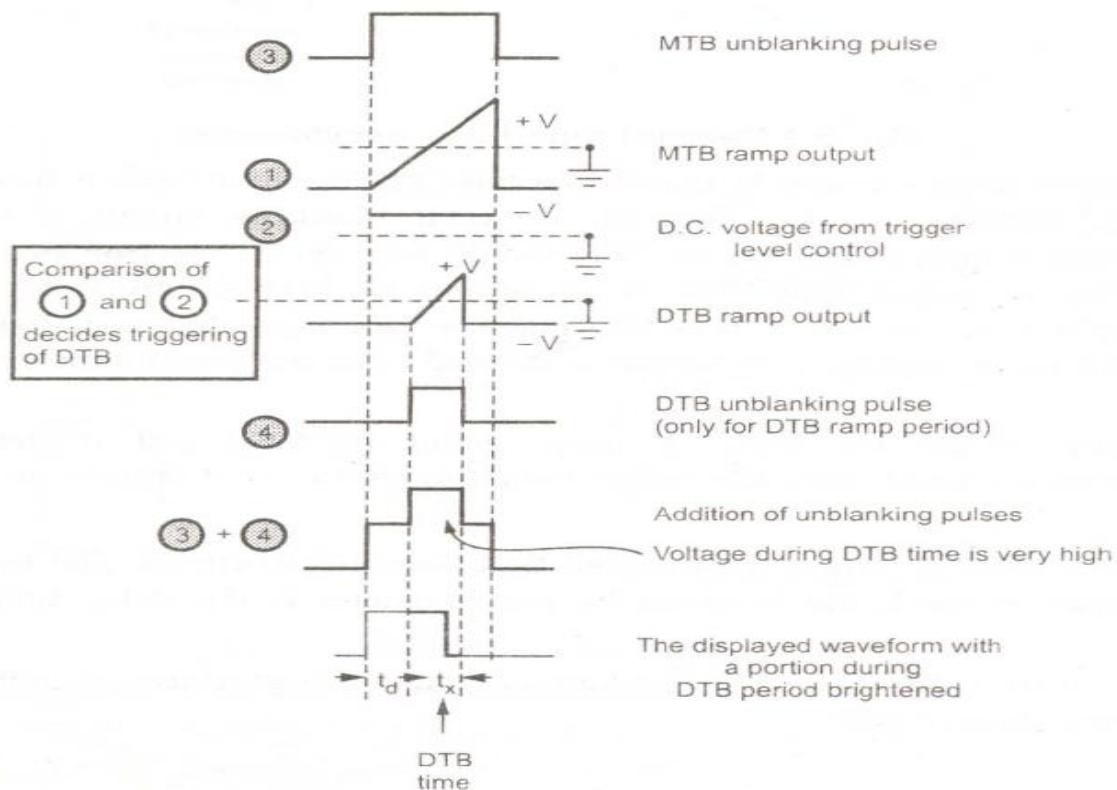

Analog storage oscilloscope:

The conventional cathode ray tube has the persistence of the phosphor ranging from a few milliseconds to several seconds. But sometimes it is necessary to retain the image for much 'longer periods, upto several hours. It requires storing of a waveform for a certain duration,' independent of phosphor persistence. Such a retention property helps to display the waveforms of very low frequency.

Mainly two types of storage techniques are used in cathode ray tubes which are:

- i) Mesh storage and ii) Phosphor storage

Sampling Time Base:

The time base circuit of the sampling oscilloscope is different than the conventional oscilloscope.

The time base of sampling oscilloscope has two functions:

- i) To move the dots across the screen
- ii) To generate the sampling command pulses for the sampling circuit.

It consists of synchronous circuit, which determines the sampling rate and establishes a reference point in time with respect to the input signal. The time base generates a triggering pulse which activates the oscillator to generate a ramp voltage. Similarly it generates a stair case waveform. The ramp generation is based on the output of the synchronizing circuit.

Both the ramp as well as staircase waveforms are applied to a voltage comparator. This comparator compares the two voltages and whenever these two voltages are equal, it generates a sampling pulse. This pulse then momentarily bias the diodes of the sampling gate in the forward direction and thus diode switch gets closed for short duration of time.

The capacitor charges but for short time hence, it can charge to only a small percentage of the input signal value at that instant. This voltage is amplified by the vertical amplifier and then applied to the vertical deflecting plates. This is nothing but a sample. At the same time, the comparator gives a signal to the staircase generator to advance through one step. This is applied to horizontal deflecting plates, thus during each step of the stair case waveform, the spot moves across the screen. Thus the sampling time base is called a staircase-ramp generator in case of a sampling oscilloscope.

Block diagram of Sampling Oscilloscope:

The block diagram of sampling oscilloscope is shown in the Fig.

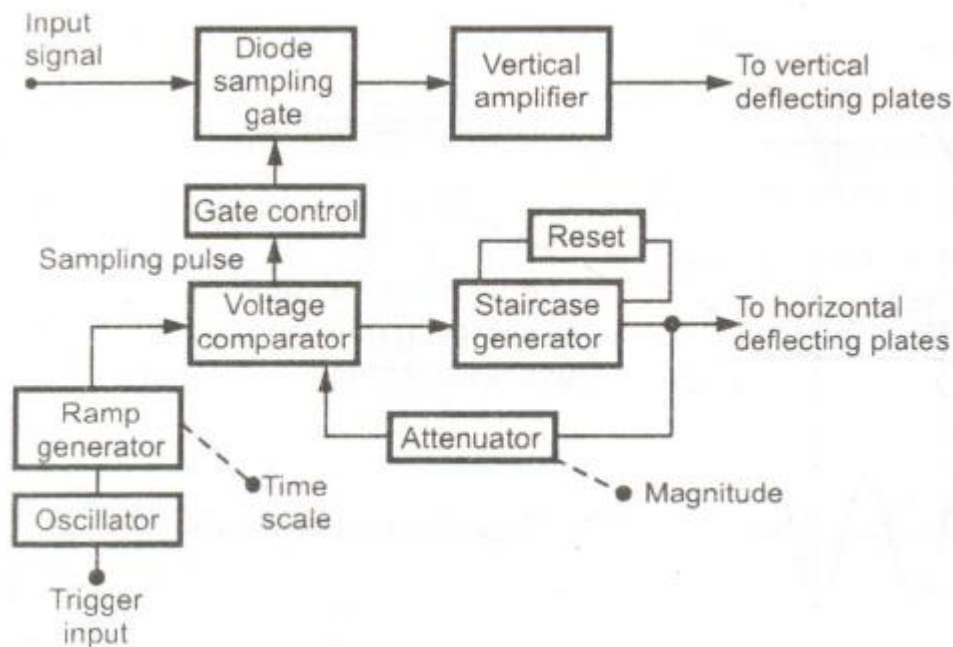

The input signal is applied to the diode sampling gate. At the start of each sampling cycle a trigger input pulse is generated which activates the blocking oscillator. The oscillator output is given to the ramp generator which generates the linear ramp signal. Since the sampling must be synchronized with the input signal frequency, the signal is delayed in the vertical amplifier.

The staircase generator produces a staircase waveform which is applied to an attenuator. The attenuator controls the magnitude of the staircase signal and then it is applied to a voltage comparator. Another input to the voltage comparator is the output of the ramp generator. The voltage comparator compares the two signals and produces the output pulse when the two voltages are equal. This is nothing but a sampling pulse which is applied to sampling gate through the gate control circuitry.

This pulse opens the diode gate and sample is taken in. This sampled signal is then applied to the vertical amplifier and the vertical deflecting plates. The output of the staircase generator is also applied to the horizontal deflecting plates.

During each step of staircase the spot moves on the screen. The comparator output advances the staircase output through one step. After certain number of pulses about thousand or so, the staircase generator resets. The smaller the size of the steps of the staircase generator, larger is the number of samples and higher is the resolution of the image.

Digital Storage Oscilloscope:

In this digital storage oscilloscope, the waveform to be stored is digitised and then stored in a digital memory. The conventional cathode ray tube is used in this oscilloscope hence the cost is less. The power to be applied to memory is small and can be supplied by small battery. Due to this the stored image can be displayed indefinitely as long as power is supplied to memory. Once the waveform is digitised then it can be further loaded into the computer and can be analysed in detail.

Block Diagram:

The block diagram of digital storage oscilloscope is shown in the Fig.

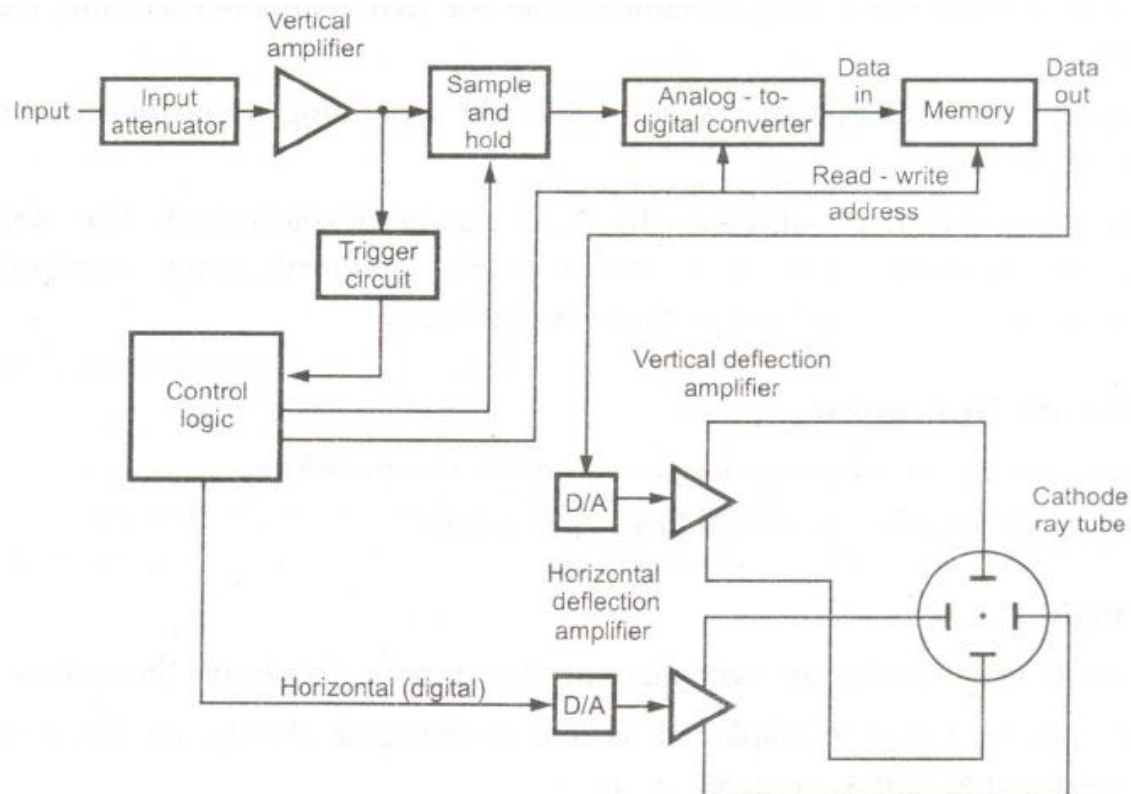

As done in all the oscilloscopes, the input signal is applied to the amplifier and attenuator section. The oscilloscope uses same type of amplifier and attenuator circuitry as used in the conventional oscilloscopes. The attenuated signal is then applied to the vertical amplifier.

The vertical input, after passing through the vertical amplifier, is digitised by an analog to digital converter to create a data set that is stored in the memory. The data set is processed by the microprocessor and then sent to the display.

To digitise the analog signal, analog to digital (*AID*) converter is used. The output of the vertical amplifier is applied to the *AID* converter section. The main requirement of *AID* converter in the digital storage oscilloscope is its speed, while in digital voltmeters accuracy and resolution were the main requirements. The digitised output needed only in the binary form and not in BCD. The successive approximation type of *AID* converter is most oftenly used in the digital storage oscilloscopes.

Modes of operation:

The digital storage oscilloscope has three modes of operation:

1. Roll mode ii) Store mode iii) Hold or save mode.

Roll mode:

This mode is used to display very fast varying signals, clearly on the screen. The fast varying signal is displayed as if it is changing slowly, on the screen. In this mode, the input signal is not triggered at all.

Recommended questions:

1. *Explain why time delay is necessary in oscilloscopes?*
2. *Sketch and explain the block diagram of delayed time base oscilloscope.*
3. *Explain with the help of waveforms, how a portion to be studied is brightened in delayed time base oscilloscope.*
4. *Describe the following storage techniques used in storage oscilloscopes:[jun 09]*
 - i) Mesh storage
 - ii) Phosphor storage
5. *Compare the mesh and phosphor storage techniques.*
6. *Draw and explain the block diagram of digital storage oscilloscope.[jul 07]*
7. *State the advantages of sampling oscilloscope*
8. *Explain the expanded mode operation of sampling oscilloscope*
9. *Explain the special function which can be performed by digital storage oscilloscope.*
10. *Explain the applications of digital storage oscil/oscope.[jul 08]*

Unit:V

Hrs: 06

Syllabus:

Signal Generators

Introduction, Fixed and variable AF oscillator, Standard signal generator, Laboratory type signal generator, AF sine and Square wave generator, Function generator, Square and Pulse generator, Sweep frequency generator, Frequency synthesizer (Text 1: 8.1 to 8.9 &Text 2: 11.5, 11.6)

Recommended readings:

1. “Electronic Instrumentation”, H. S. Kalsi, TMH, 2004
2. “Electronic Instrumentation and Measurements”, David A Bell, PHI / Pearson Education, 2006.

Unit 5:**Signal Generators****06 Hours****Introduction:**

Signal generator provides variety of different signals for testing various electronic circuits at low powers. The signal generator is an instrument which provides several different output waveforms including sine wave, square wave, triangular wave, pulse train and an amplitude modulated waveform.

Requirements of Laboratory Type Signal Generator:

There are different types of signal generator. But the requirements are common to all the types.

- i) The output frequency of signal generator should be very stable .
- ii) The amplitude of output signal of signal generator should be controllable from low values to relatively large values.
- iii) The amplitude of output signal must be stable. the harmonic contents in the output should be as low as possible. The output signal should be distortion free.
- v) The signal generator should provide very low spurious output; that means effect of hum, noise, jitter and modulation should be negligible.

A F oscillator:

The signal generators which provide sinusoidal waveforms in the frequency range of 20 Hz to 20 kHz are called audio frequency(A.F.) signal generator. Depending upon the load, in modern AF signal generators a provision is made to select output impedance either 50 Ω or 600 Ω . To generate audio frequency signals, in practice RC feedback oscillators are used. The most commonly used RC feedback oscillators are Wien Bridge oscillator and RC phase shift oscillator. Let us discuss both the types of oscillators in detail.

Wien Bridge Oscillator using Op-amp:

The Fig shows the Wien bridge oscillator using an op-amp.

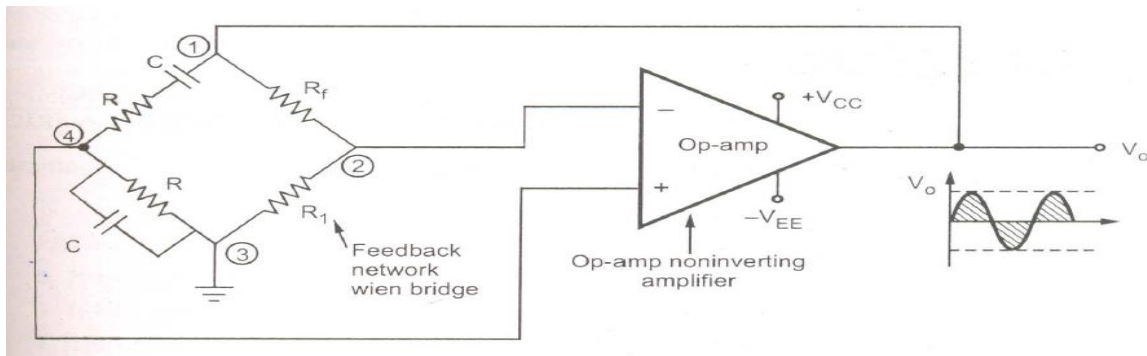

where resistance R and capacitor C are the components of frequency sensitive arms of the bridge. The resistance R_f and R₁ form the part of the feedback path. The gain of noninverting op-amp can be adjusted using the resistance R_f and R₁. The gain of op-amp is,

$$A = 1 + \frac{R_f}{R_1}$$

Standard signal generator:

It is extensively used in the testing of radio receivers and transmitters. This is basically a radio frequency (RF) signal generator. The standard signal generator produces known and controllable voltages.

Principle of working:

The output of the generator is amplitude modulated or frequency modulated. The frequency modulation is possible using a carrier signal from RF oscillator. The amplitude modulation can be done using internal sine wave oscillator. The modulation may be done by a sine wave, square wave, triangular wave or a pulse also. The setting on the front panel indicates the carrier frequency to be used for modulation.

Block Diagram:

The block diagram of conventional standard signal generator is shown in the Fig.

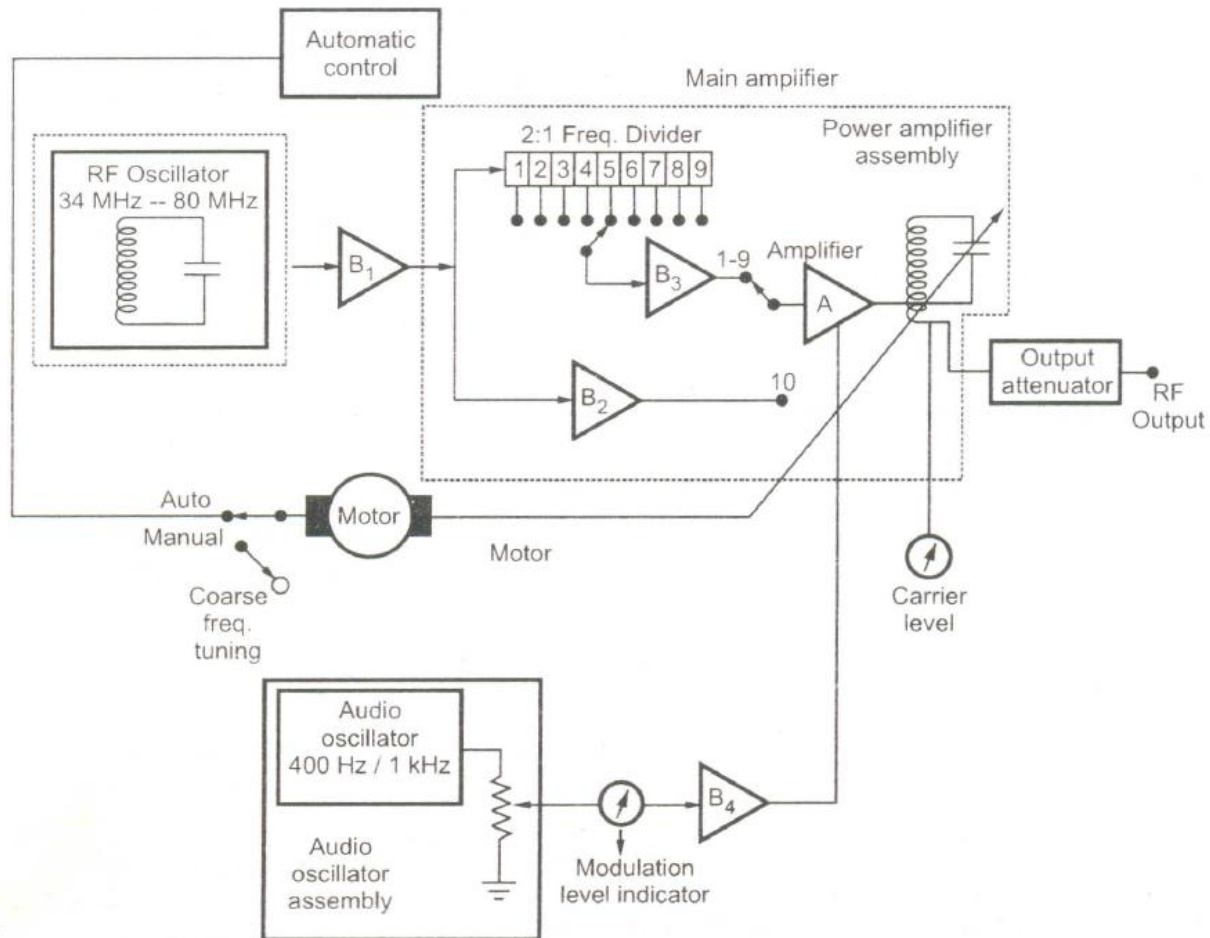

Signal for modulation is provided by an audio oscillator. The frequency given by this oscillator is in the range of 400 Hz to 1 kHz. The modulation takes place in main amplifier, in power amplifier stage. The level of modulation can be adjusted up to 95% by using control devices.

The lowest frequency range obtained by using frequency divider is the highest frequency range divided by 29 or 512. Thus, frequency stability of the highest range is imparted to the lowest frequency range. The effects of frequency range selection are eliminated as the same oscillator is used for all frequency bands. The master oscillator is tuned automatically or manually. In an automatic controller for tuning the master oscillator, a motor-driven variable capacitor is used. This system is extensively used in programmable automatic frequency control devices. The oscillator can be fine-tuned by means of a large rotary switch with each division corresponding to 0.01% of the main dial setting.

The internal calibration is provided by a 1 MHz crystal oscillator. The small power

consumption of the instruments makes output with very low ripple. The supply voltage of the master oscillator is regulated by temperature compensated reference circuit. The output of the main amplifier is given to an output attenuator. The attenuator controls the amplitude level and provides the required stable **RF** output.

AF sine and square wave generator:

The block diagram of an AF sine-square wave generator is as shown in the Fig

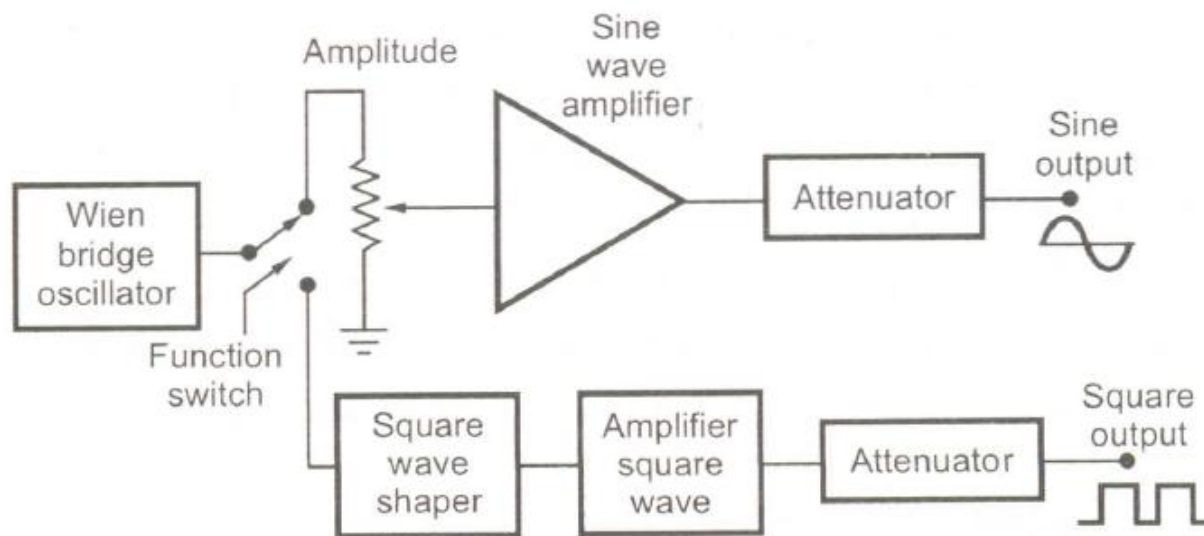

As per our previous discussion, Wien bridge oscillator is the heart of an AF sine-square wave generator. Depending upon the position of switch, we get output as square wave output or sine wave output. The Wien bridge oscillator generates a sine wave. Depending upon the position of switch, it is switched to either circuit. In the square wave generation section, the output of the Wien bridge oscillator is fed to square wave shaper circuit which uses schmitt trigger circuit. The attenuators in both the sections are used to control output signal level. Before attenuation, the signal level is made very high using sine wave amplifier and square wave amplifier.

Square wave and pulse generator:

The square wave generator and pulse generator are generally used as measuring devices in combination with the oscilloscope. The basic difference between square wave generator and pulse generator is in the duty cycle. The duty cycle is defined as the ratio of average value of a pulse over one cycle to the peak value. It is also defined as ratio of the

pulse width to the period of one cycle.

$$\text{Duty cycle} = \frac{\text{Pulse width}}{\text{Pulse period}}$$

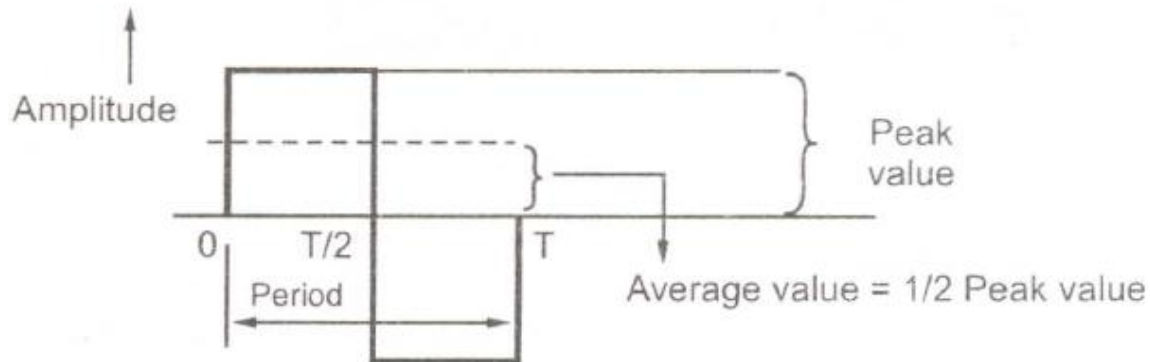

The average value is half of peak value. Both the average value and peak value are inversely proportional to time duration. The average value of a pulse is given as,

1

Average value = $1/2$ Peak value

Duty cycle of square wave = 0.5

Thus square wave generator produces an output voltage with equal ON and OFF periods as duty cycle is 0.5 or 50% as the frequency of oscillation is varied. Then we can state that irrespective of the frequency of operation, the positive and negative half cycles extend over half of the total period

Laboratory type square wave and pulse generator:

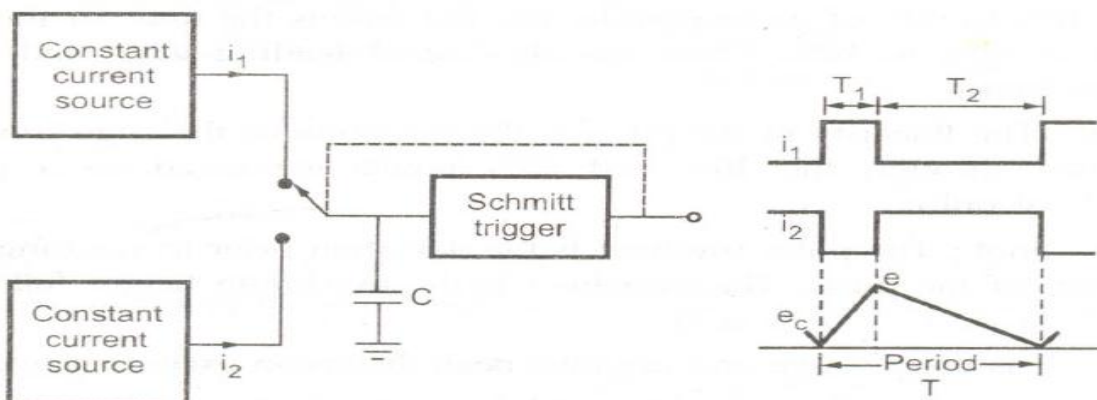

The circuit consists of two current sources, a ramp capacitor, and Schmitt trigger circuit as well as current source circuit. The two current sources provide a constant current to a ramp capacitor for charging and discharging. The ratio of these charging and discharging current is determined by setting of symmetry control. The symmetry control determines duty cycle of output waveform. In the current source, an appropriate control voltage is applied to current control transistors which controls the frequency i.e. sum of two currents. The multiplier switch provides decade switching control output frequency. While frequency dial provides continuous vernier control of output frequency.

The block diagram of laboratory type square wave and pulse generator is as shown in fig:

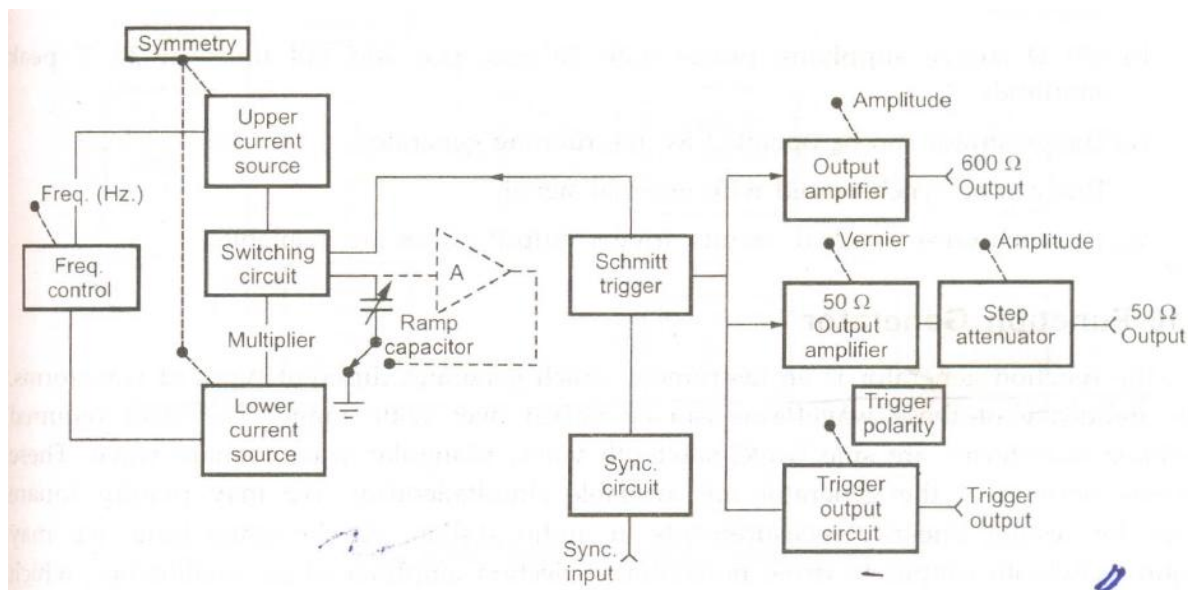

Function generator:

The function generator is an instrument which generates different types of waveforms. The frequency of these waveforms can be varied over a wide range. The most required common waveforms are sine wave, sawtooth wave, triangular wave, square wave. These various outputs of the generator are available simultaneously. We may require square wave for testing linearity measurements in audio system. At the same time, we may require sawtooth output to drive horizontal deflection amplifier of an oscilloscope which gives visual display of the measurements. The purpose of providing simultaneous waveforms is fulfilled by the function generator.

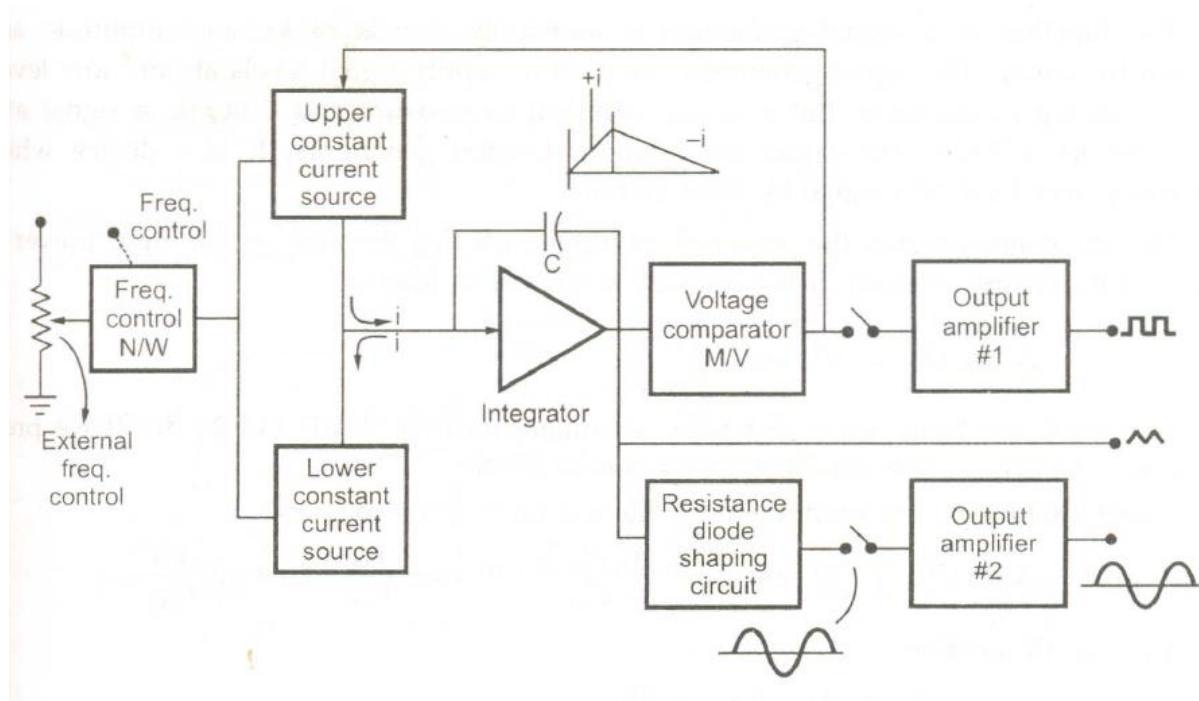
Block Diagram:

The frequency controlled voltage is used to regulate two current sources namely upper current source and lower current source. The upper current source supplies constant current to an integrator. The output voltage of integrator then increases linearly with time. If the current, charging the capacitor increases or decreases, the slope of output voltage increases or decreases respectively. Hence this controls frequency. The voltage comparator multivibrator circuit changes the state of the network when the output voltage of integrator equals the maximum predetermined upper level. Because of this change in state, the upper current source is removed and the lower current source is switched ON. This lower current source supplies opposite current to the integrator circuit. The output of integrator decreases linearly with time. When this output voltage equals maximum predetermined upper level on negative side, the voltage comparator multivibrator again changes the condition of the network by switching OFF the lower current source and switching ON the upper current source.

The output voltage of the integrator has triangular waveform. The frequency of this triangular waveform is determined by the magnitudes of the currents supplied by upper current source and lower current source. To get square wave, the output of the integrator

is passed through comparator. The voltage comparator delivers square wave output voltage of same frequency as that of input triangular waveform. The sine wave is derived from triangular wave. The triangular wave is synthesised into sine wave using diode resistance network. **In** this shaper circuit, the slope of triangular wave is changed as its amplitude changes. This results in a sine wave with less than 1% distortion.

The two output amplifiers provide two simultaneous, individually selected outputs of any of the waveform functions.

The function of a signal generators is to supply signals of known amplitude and known frequency. The signal generators are used to supply signal levels at very low levels for the testing of receivers. But it is very difficult to measure and calibrate a signal at a very low level. Thus attenuators are used in function generators. It is a device which reduces power level of a signal by fixed amount.

Sweep-Frequency Generators:

The sine wave generator discussed in earlier sections generates output voltage at a known and stable frequency.

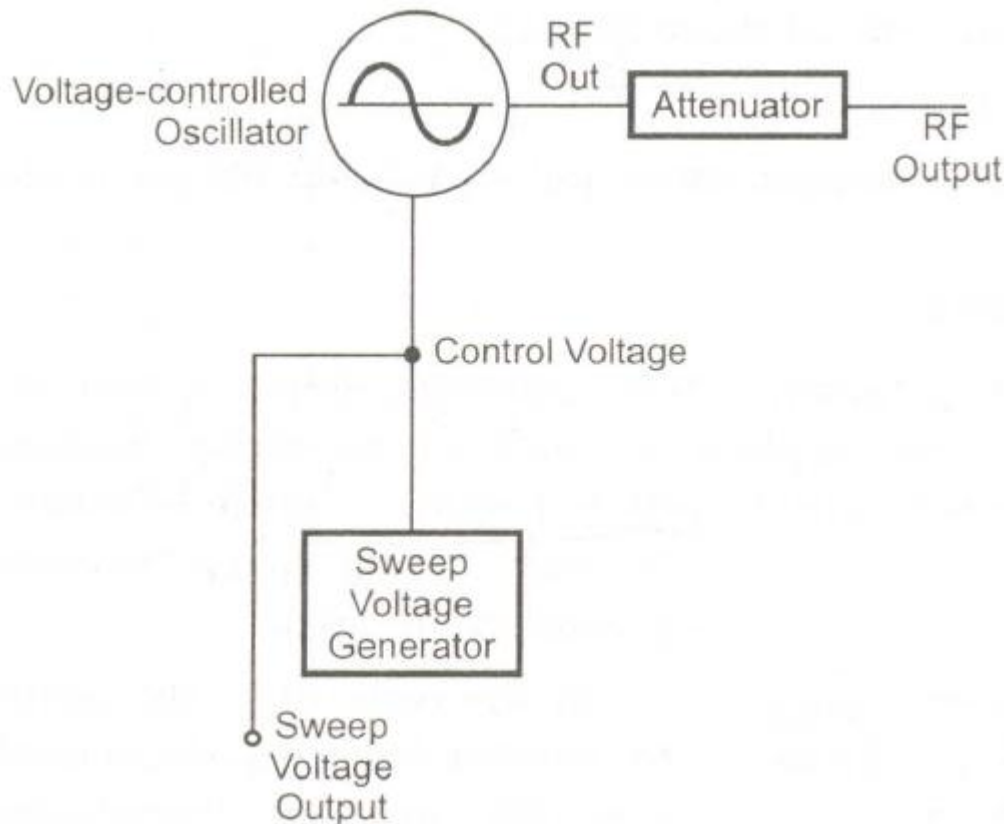

The development of solid state variable capacitance diode (varicap diode) helps in building sweep frequency generators. These are extensively used than any other electronic devices. These varicap diodes provide the method of electronically tuning an oscillator. The block diagram of simple sweep frequency generator is as shown in Fig

The sweep generator is very much similar to the simple signal generator. In the simple signal generator, an oscillator is tuned to fixed single frequency.

In the sweep generator, an oscillator is electronically tuned and by using voltage controlled oscillator variable frequency is obtained. As name indicates, a sweep voltage generator provides voltage, known as control voltage, to the voltage controlled oscillator (VCO). The function of voltage controlled oscillator is to provide various frequency sweeps according to voltage provided by sweep voltage generator.

Frequency Synthesizers:

The frequency generators are of two types.

1. One is free running frequency generators in which the output can be tuned continuously either electronically or mechanically over a wide frequency range. The generators discussed uptill now are of this type.

2. The second is frequency generator with frequency synthesis technique. The synthesis means to use a fixed frequency oscillator called reference oscillator or *clock* and to derive the wide frequency range in steps from the output of the reference oscillator.

The stability and accuracy of free running frequency generator is poor while frequency synthesizers provide output which is arbitrarily selectable, stable and accurate frequency. The reference oscillator used in frequency synthesizers is generally precision crystal oscillator with an output at some cardinal frequency such as 10 MHz. Various signal processing circuits then operate in synchronism to provide a large choice of the output frequencies.

Recommended questions:

1. State the requirements for synthesizer? [**jan 07,09 jul 05, 08**]
2. Draw the basic block diagram of signal generator. [**asked in almost every paper**]
3. What is sweep frequency generator? [**jun 06**]
4. What is function generator? [**jan 05**]

Unit:VI**Hrs: 07****Syllabus:****Measurement of resistance, inductance and capacitance**

Whetstone's bridge, Kelvin Bridge; AC bridges, Capacitance Comparison Bridge, Maxwell's bridge, Wein's bridge, Wagner's earth connection (Text 1: 11.1 to 11.3, 11.8, 11.9, 11.11, 11.14 and 11.15)

Recommended readings:

1. "Electronic Instrumentation", H. S. Kalsi, TMH, 2004
2. "Electronic Instrumentation and Measurements", David A Bell, PHI / Pearson Education, 2006.

Unit 6: Measurement of resistance, inductance and capacitance **06 Hours**

Introduction:

A bridge circuit in its simplest form consists of a network of four *resistance arms* forming a closed circuit. A source of current is applied to two opposite junctions. The current detector is connected to other two junctions.

The bridge circuits use the comparison measurement methods and operate on null-indication principle. The bridge circuit compares the value of an unknown component with that of an accurately known standard component. Thus *the* accuracy depends on the bridge components and not on the null indicator. Hence high degree of accuracy can be obtained.

Advantages of Bridge Circuit:

The various advantages of the bridge circuit are,

- 1) The balance equation is independent of the magnitude of the input voltage or its source impedance. These quantities do not appear in the balance equation expression.
- 2) The measurement accuracy is high as the measurement is done by comparing the unknown value with the standard value.
- 3) The accuracy is independent of the characteristics of a null detector and is dependent on the component values.
- 4) The balance equation is independent of the sensitivity of the null detector, the impedance of the detector or any impedance shunting the detector.
- 5) The balance condition remains unchanged if the source and detector are interchanged.

Wheatstone's bridge:

The bridge consists of four resistive arms together with a source of e.m.f. and a null detector. The galvanometer is used as a null detector.

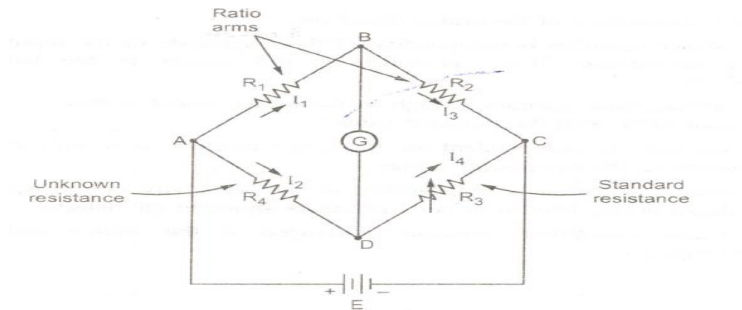

The arms consisting the resistances R_1 and R_2 are called ratio arms. The arm consisting the standard known resistance R_3 is called standard arm. The resistance R_4 is the unknown resistance to be measured. The battery is connected between A and C while galvanometer is connected between Band D.

Kelvin bridge:

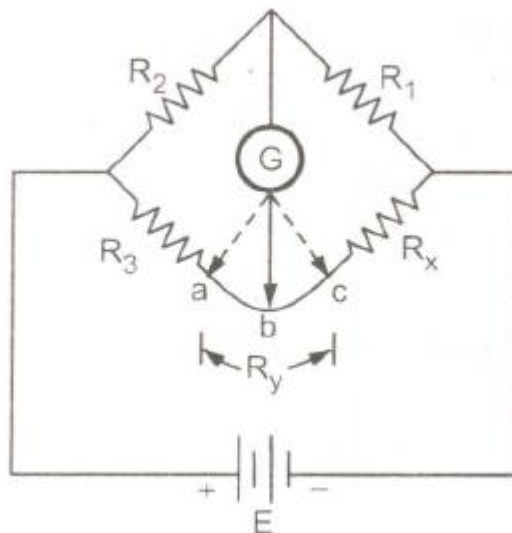

In the Wheatstone bridge, the bridge contact and lead resistance causes significant error, while measuring low resistances. Thus for measuring the values of resistance below 1Ω , the modified form of Wheatstone bridge is used, known as Kelvin bridge. The consideration of the effect of contact and lead resistances is the basic aim of the Kelvin bridge.

The resistance R_v represents the resistance of the connecting leads from R_1 to R_2 . The resistance R_x is the unknown resistance to be measured.

\ The galvanometer can be connected to either terminal a, b or terminal c. When it is connected to a, the lead resistance R_y gets added to R_x hence the value measured by the bridge, indicates much higher value of R_x .

If the galvanometer is connected to terminal c, then R_y gets added to R_3 . This results in the measurement of R_x much lower than the actual value.

The point b is in between the points a and c, in such a way that the ratio of the resistance from c to b and that from a to b is equal to the ratio of R_1 and R_2 .

$$\frac{R_{cb}}{R_{ab}} = \frac{R_1}{R_2}$$

A.C. Bridges:

An a.c. bridge in its basic form consists of four arms, a source of excitation and a balance detector. Each arm consists of an impedance. The source is an a.c. supply which supplies a.c. voltage at the required frequency. For high frequencies, the electronic oscillators are used as the source. The balance detectors commonly used for a.c. bridge are head phones, tunable amplifier circuits or vibration galvanometers. The headphones are used as detectors at the frequencies of 250 Hz to 3 to 4 kHz. While working with single frequency a tuned detector is the most sensitive detector. The vibration galvanometers are useful for low audio frequency range from 5 Hz to 1000 Hz but are commonly used below 200 Hz. Tunable amplifier detectors are used for frequency range of 10 Hz to 100 Hz.

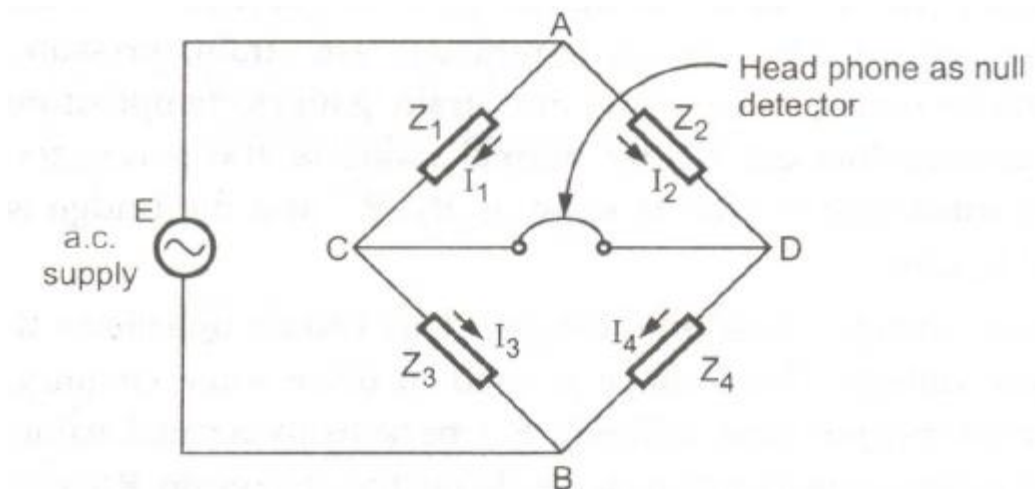

Capacitance Comparison Bridge:

In the capacitance comparison bridge the ratio arms are resistive in nature. The impedance Z_3 consists of the known standard capacitor C_3 in series with the resistance R_3 . The resistance R_3 is variable, used to balance the bridge. The impedance Z_4 consists of the unknown capacitor C_x and its small leakage resistance R_x .

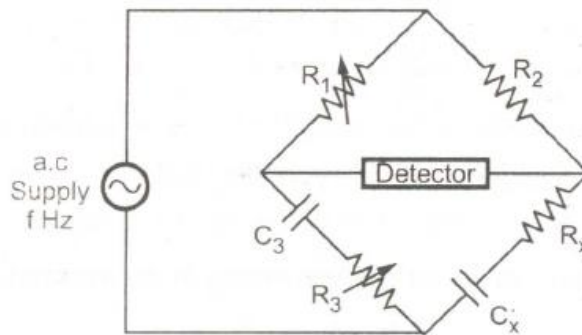

Maxwell's Bridge :

Maxwell's bridge can be used to measure inductance by comparison either with a variable standard self inductance or with a standard variable capacitance. These two measurements can be done by using the Maxwell's bridge in two different forms.

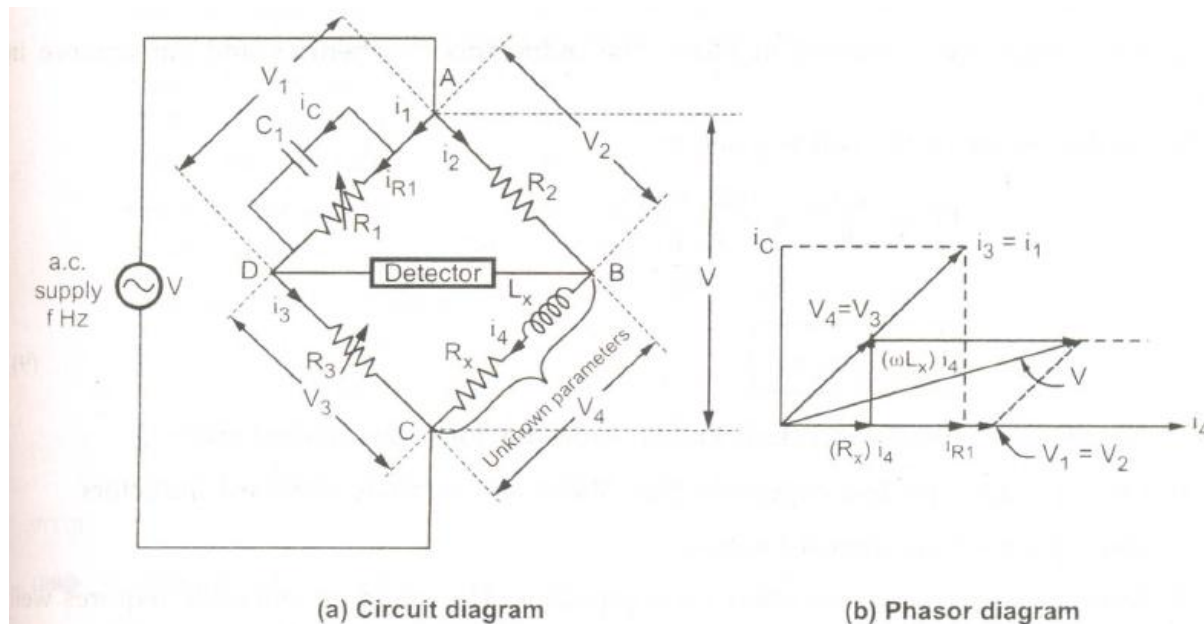

Maxwell's inductance capacitance bridge

Recommended questions:

1. Explain maxwell's bridge.
2. Explain kelvin's bridge.
3. Explain the importance of wheatstone bridge.[**jun 08, 09**]

Unit:VII

Hrs: 07

Syllabus:

Transducers - I

Introduction, Electrical transducers, Selecting a transducer, Resistive transducer, Resistive position transducer, Strain gauges, Resistance thermometer, Thermistor, Inductive transducer, Differential output transducers and LVDT, (Text 1: 13.1 to 13.11)

Recommended readings:

1. “Electronic Instrumentation”, H. S. Kalsi, TMH, 2004
2. “Electronic Instrumentation and Measurements”, David A Bell, PHI / Pearson Education, 2006.

Unit 7:**Transducers – I****07 Hours****Introduction:**

The primary objective of process control is to control the physical parameters such as temperature, pressure, flow rate, force, level etc. The system used to maintain these parameters constant, close to some desired specific value is called **process control system**. These parameters may change because of internal and external disturbances hence a constant corrective action is required to keep these parameters constant or within the specified range.

It consists of four elements,

1. Process 2. Measurement 3. Controller 4. Control element.

A device which converts a physical quantity into the proportional electrical signal is called a transducer.

The electrical signal produced may be a voltage, current or frequency. A transducer uses many effects to produce such conversion. The process of transforming signal from one form to other is called transduction. A transducer is also called pick up.

The transduction element transforms the output of the sensor to an electrical output, as shown in the Fig.

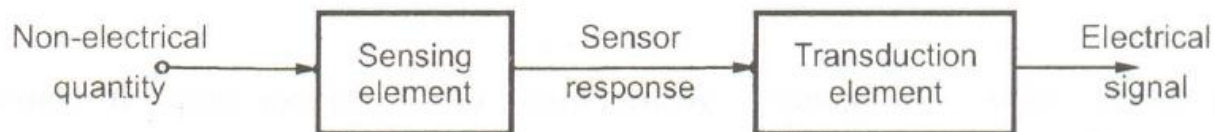
**Transducer elements in cascade**

The common range of an electrical signal used to represent analog signal in the industrial environment is 0 to 5 V or 4 to 20 mA. In industrial applications, nowadays, 4 to 20 mA range is most commonly used to represent analog signal. A current of 4 mA represents a zero output and current of 20 mA represents a full scale value i.e. 5 V in case of voltage representation. The zero current condition represents open circuit in the signal transmission line. Hence the standard range is offset from zero.

Many a times, the transducer is a part of a circuit and works with other elements of that circuit to produce the required output. Such a circuit is called signal conditioning

circuit.

Passive transducer:

In electrical circuits, there are combinations of three passive elements : resistor, inductor and capacitor. These three passive elements are described with the help of the primary parameters such as resistance, self or mutual inductance and capacitance respectively. Any change in these parameters can be observed only if they are externally powered. We have studied that the passive transducers do not generate any electrical signal by themselves and they require some external power to generate an electrical signal. The transducers based on variation of parameters such as resistance, self or mutual inductance capacitance, due to an external power are known as passive transducers. Hence resistive transducer, inductive transducer and capacitive transducer are the basic passive transducers.

Resistive transducer:

In general, the resistance of a metal conductor is given by,

$$R = \frac{\rho L}{A}$$

where ρ = Resistivity of conductor ($\Omega \text{ m}$)

L = Length of conductor (m)

A = Area of cross-section of conductor (m^2)

The electrical resistive transducers are designed on the basis of the methods of variation of any one of the quantities in above equation; such as change in length, change in area of cross-section and change in resistivity.

The sensing element which is resistive in nature, may be in different forms depending upon the mechanical arrangement. The change in pressure can be sensed by using sensitive resistive elements. The resistance pressure transducers may use Bellow, Diaphragm or Bourdon tube.

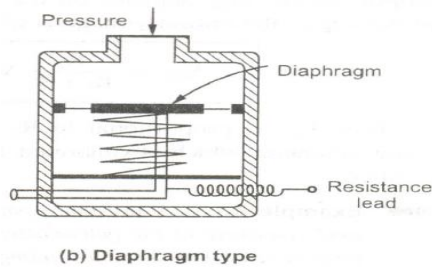

Resistance Position Transducer:

In many industrial measurements and control applications, it is necessary to sense position of the object or the distance that object travels. For such applications, simple resistance position transducer is very useful.

It works on the principle that resistance of the sensing element changes due to the variations in physical quantity being measured.

A simple resistance position transducer is as shown in the Fig.

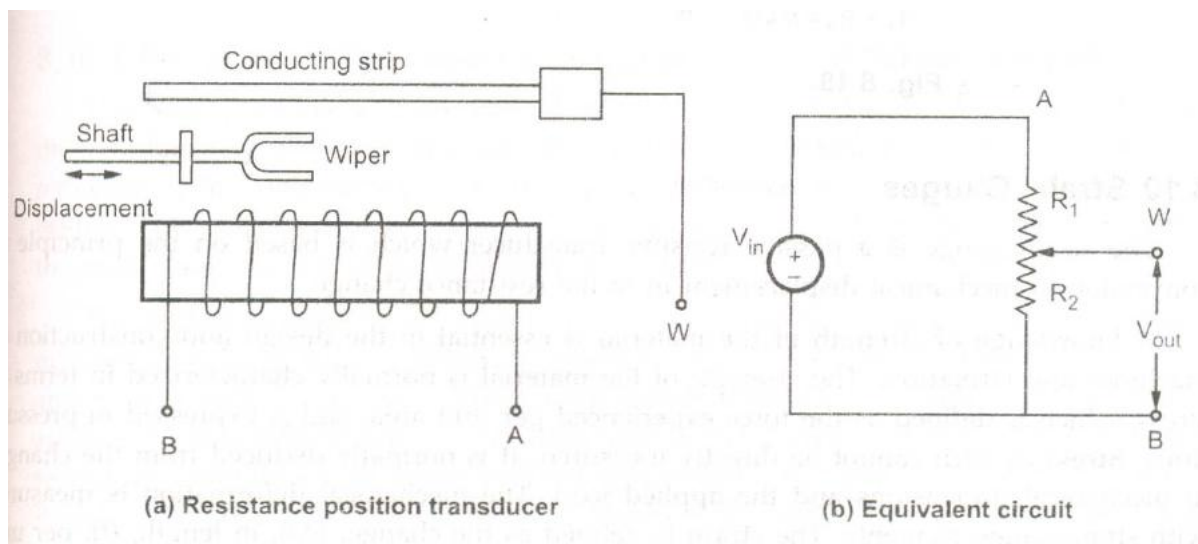

The transducer consists a sliding contact or wiper. A resistive element is mounted with the sliding contact which is linked with the object whose position is to be monitored.

Depending upon the position of the object, the resistance between slider and the one end of resistive element varies. The equivalent circuit is as shown in the Fig. 8.18 (b). The output voltage V_{out} depends on the position of the wiper. Thus depending upon position of the wiper, the output voltage is given by,

$$V_{out} = \frac{R_2}{R_1 + R_2} V_{in}$$

Thus V_{out} is proportional to R_2 i.e. wiper position. The output voltage is measured using voltmeter which is calibrated in centimeters and allows direct readout of the object position.

Strain gauges:

The strain gauge is a passive resistive transducer which is based on the principle of conversion of mechanical displacement into the resistance change.

A knowledge of strength of the material is essential in the design and construction of machines and structures. The strength of the material is normally characterized in terms of stress, which is defined as the force experienced per unit area, and is expressed in pressure units. **Stress** as such cannot be directly measured. It is normally deduced from the changes in mechanical dimensions and the applied load. The mechanical deformation is measured with strain-gauge elements. The **strain** is defined as the change, (Δl), in length, (l), per unit length and is expressed as ϵ in microstrains.

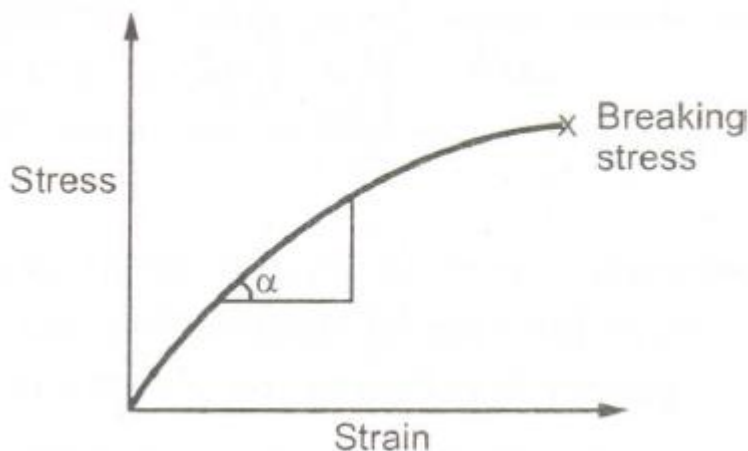

Stress-strain curves for typical metals specimen

The most common materials used for wire strain gauges are constantan alloys containing 45% Nickel and 55% Copper, as they exhibit high specific resistance, constant gauge factor over a wide

strain range, and good stability over a reasonably large temperature range (from 0°C to 300°C). For dynamic strain measurements, Nichrome alloys, containing 80% Nickel and 20% Chromium are used. They can be compensated for temperature with platinum.

Bonding cements are adhesives used to fix the strain gauge onto the test specimen. This cement serves the important function of transmitting the strain from the specimen to the gauge-sensing element. Improper bonding of the gauge can cause many errors.

Basically, the cement can be classified under two categories, viz, solvent-setting cement and chemically-reacting cement. Duco cement is an example of solvent-setting cements which is cured by solvent evaporation. Epoxies and phenolic bakelite cement are chemically-reacting cements which are cured by polymerization. Acrylic cements are contact cements that get cured almost instantaneously. The proper functioning of a strain gauge is wholly dependent on the quality of bonding which holds the gauge to the surface of the structure undergoing the test.

Derivation of Gauge Factor:

The gauge factor is defined as the unit change in resistance per unit change in length.

It is denoted as K or S. It is also called sensitivity of the strain gauge.

$$S = \frac{\Delta R/R}{\Delta l/l}$$

S = Gauge factor or sensitivity

R = Gauge wire resistance

ΔR = Change in wire resistance

l = Length of the gauge wire in unstressed condition

Δl = Change in length in stressed condition.

Derivation: Consider that the resistance wire is under tensile stress and it is deformed by $\sim l$ as shown in the Fig.

When uniform stress (J) is applied to this wire along the length, the resistance R

Let ρ = Specific resistance of wire material in $\Omega\text{-m}$

l = Length of the wire in m

A = Cross-section of the wire in m^2

changes to $R + \Delta R$ because of change in length and cross-sectional area.

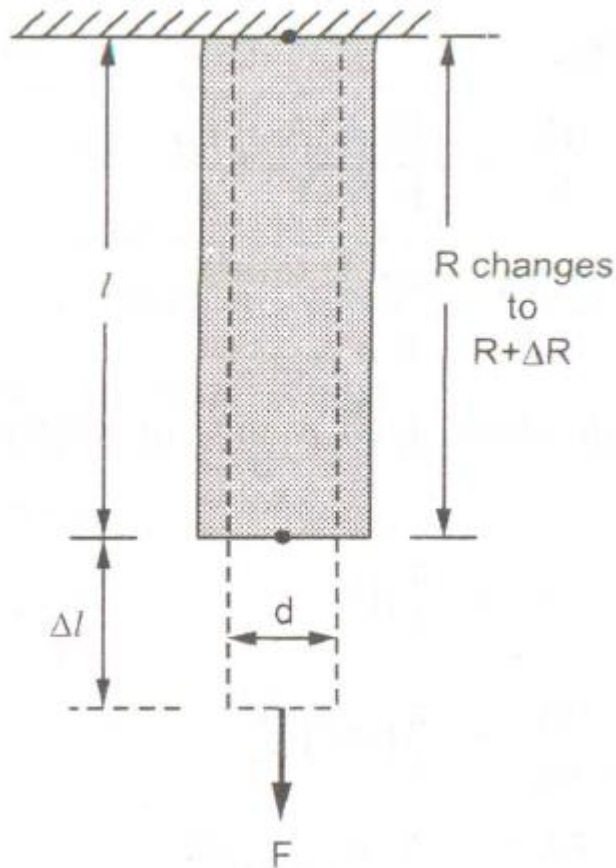

$$\sigma = \text{Stress} = \frac{\Delta l}{l}$$

$\Delta l/l$ = Per unit change in length

$\Delta A/A$ = Per unit change in area

$\Delta \rho/\rho$ = Per unit change in resistivity
(specific resistance)

$$R = \frac{\rho l}{A}$$

$$\therefore \frac{dR}{d\sigma} = \frac{d\left(\frac{\rho l}{A}\right)}{d\sigma} = \frac{\rho}{A} \frac{\partial l}{\partial \sigma} - \frac{\rho l}{A^2} \frac{\partial A}{\partial \sigma} + \frac{l}{A} \frac{\partial \rho}{\partial \sigma}$$

Note that $\frac{\partial}{\partial \sigma} \left(\frac{1}{A} \right) = -\frac{1}{A^2} \frac{\partial A}{\partial \sigma}$

Multiply both sides by $\frac{1}{R}$,

$$\frac{1}{R} \frac{dR}{d\sigma} = \frac{\rho}{RA} \frac{\partial l}{\partial \sigma} - \frac{1}{R} \frac{\rho l}{A^2} \frac{\partial A}{\partial \sigma} + \frac{l}{RA} \frac{\partial \rho}{\partial \sigma}$$

Using $R = \frac{\rho l}{A}$ on right hand side,

$$\frac{1}{R} \frac{dR}{d\sigma} = \frac{1}{l} \frac{\partial l}{\partial \sigma} - \frac{1}{A} \frac{\partial A}{\partial \sigma} + \frac{1}{\rho} \frac{\partial \rho}{\partial \sigma}$$

Canceling $\partial \sigma$ from both sides,

$$\frac{dR}{R} = \frac{dl}{l} - \frac{dA}{A} + \frac{\partial \rho}{\rho}$$

i.e. $\frac{\Delta R}{R} = \frac{\Delta l}{l} - \frac{\Delta A}{A} + \frac{\Delta \rho}{\rho}$

Types of Strain Gauges:

Depending upon the principle of operation and their constructional features, strain gauges are classified as mechanical, optical, or electrical. Of these, the electrical strain gauges are most commonly used.

1. Mechanical Gauges : In these gauges, the change in length, $t:l$, is magnified mechanically using levers or gears. These gauges are comparatively larger in size,

and as such can be used in applications where sufficient area is available on the specimen for fixing the gauge. These gauges are employed for static strain measurements only.

2. Optical Gauges: These gauges are similar to mechanical strain gauges except that the magnification is achieved with multiple reflectors using mirrors or prisms. In one type a plain mirror is rigidly fixed to a movable knife-edge. When stress is applied, the mirror rotates through an angle, and the reflected light beam from the mirror subtends an angle twice that of the incident light. The measurement accuracy is high and independent of temperature variations.

3. Electrical Strain Gauges : The electrical strain gauges measure the changes that occur in resistance, capacitance, or inductance due to the strain transferred from the specimen to the basic gauge element. The most commonly used strain gauge is the bonded resistance type of strain gauge. The other two, viz., capacitance and inductance type are used only in special types of applications.

Basic Forms of Resistance Wire Strain Gauges:

The resistance wire strain gauges of metallic type are available in two basic forms; *bonded and unbonded type*. *Tire banded metallic* strain gauges are further classified as fiat grid, helical grid and thin foil type strain gauges.

Resistance temperature detector (RTD):

Resistance temperature detector is a primary electrical transducer which is used to measure the change in the temperature. It is commonly known as resistance thermometer. The resistance thermometers are based on the principle that the resistance of the conductor changes when the temperature changes. Basically the resistance thermometer determines the change in the electrical resistance of the conductor subjected to the temperature changes.

The temperature sensing element used in this thermometer should exhibit a relatively large change in resistance for a given change in temperature. Also the sensing element should not undergo permanent change with use or age. Another desirable characteristic for the sensing element is the linear change in resistance with change in temperature. When the sensing element is smaller in size, less heat is required to raise its temperature. This is

suitable for measurement of rapid variations in temperature. Platinum, nickel, and copper are the metals most commonly used to measure temperature. The relationship between temperature and resistance of conductor is given by equation:

$$R_t = R_{ref} [1 + \alpha \Delta t]$$

where

R_t : Resistance of the conductor at temperature $t^\circ\text{C}$,

R_{ref} : Resistance of the conductor at the reference temperature, usually 0°C ,

α : Temperature coefficient of the resistance,

Δt : Difference between the temperature to be measured & reference temperature.

Almost all metallic conductors have a *positive temperature coefficient* so that their resistance increases with an increase in temperature. A high value of α is desirable in a temperature sensing element so that a substantial change in resistance occurs for a relatively small change in temperature. This change in resistance $[\Delta R]$ can be measured with a Wheatstone bridge, the output of which can be directly calibrated to indicate the temperature which caused the change in resistance.

Most of the metals show an increase in resistivity with temperature, which is first linear and then increases in an accelerated fashion. The metals that exhibit good sensitivity and reproducibility for temperature measurement purposes are copper, nickel, and platinum. Among these, copper has the highest temperature coefficient with the most linear dependence. However, copper is generally not used due to certain practical problems. Because of its low resistivity, the size of the resistance element increases to get reasonable sensitivity. In the range below 400 K, a gold silver alloy can be used which has the same characteristic as platinum.

Construction of RTD:

The wire resistance thermometer usually consists of a coil wound on a mica or ceramic former, as shown in the Fig. The coil is wound in bifilar form so as to make it noninductive. Such coils are available in different sizes and with different resistance values ranging from 10 ohms to 25,000 ohms.

To avoid corrosion of resistive element, usually elements are enclosed in a protective

tube of pyrex glass, porcelain, quartz or nickel, depending on the range of temperature and the nature of the fluid whose temperature is to be measured. The tube is evacuated and sealed or filled with air or any other inert gas and kept around atmospheric pressure or in some cases at a higher pressure.

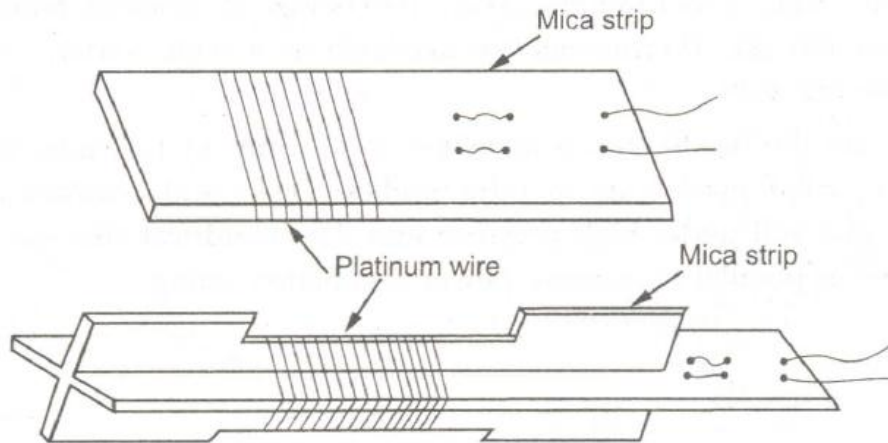

Thermistors:

Basically thermistor is a contraction of a word 'thermal resistors', The resistors depending on temperature are thermal resistors. Thus resistance thermometers are also thermistors having positive -temperature coefficients. But generally the resistors having negative temperature coefficients (NTC) are called thermistors. The resistance of a thermistor decreases as temperature increases. The NTC of thermistors can be as large as few percent per degree celcius change in temperature. Thus the thermistors are very sensitive and can detect very small changes in temperature too.

Construction of thermistor:

Thermistors are composed of a sintered mixture of metallic oxides, such as manganese, nickel, cobalt, copper, iron, and uranium. Their resistances at ambient temperature may range from 100 n to 100 ill. Thermistors are available in a wide variety of shapes and sizes as shown in the Fig. 8.29.

Smallest in size are the beads with a diameter of 0.15 mm to 1.25 mm. Beads may be sealed in the tips of solid glass rods to form probes. Disks and washers are made by pressing thermistor materia~ under high pressure into Hat cylindrical shapes. Washers can be placed in series or in parallel to increase power dissipation rating.

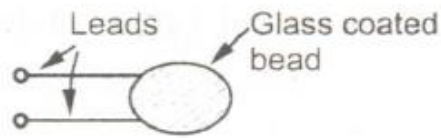

(a) Disc

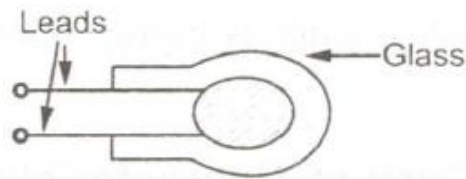

(b) Probe

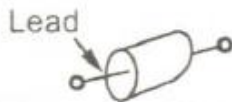

(c) Bead type



(d) Rod

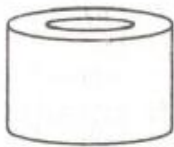

(e) Washer type

Thermistors are well suited for precision temperature measurement, temperature control, and temperature compensation, because of their *very* large change in resistance with temperature. They are widely used for measurements in the temperature range -1000 C to $+2000\text{ C}$. The measurement of the change in resistance with temperature is carried out with a Wheatstone bridge.

Linear variable differential transformer (LVDT)

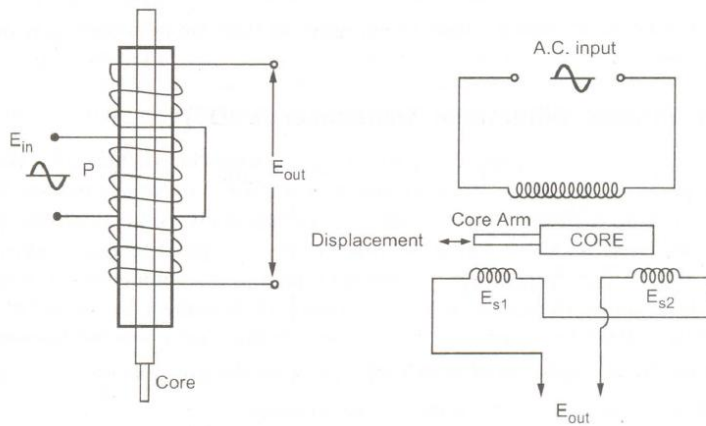

When an externally applied force moves the core to the left-hand position, more magnetic flux links the left-hand coil than the right-hand coil. The emf induced in the left-hand coil, E_{s1} , is therefore larger than the induced emf of the right-hand coil, E_{s2} . The magnitude of the output voltage is then equal to the difference between the two secondary voltages and it is in phase with the voltage of the left-hand coil.

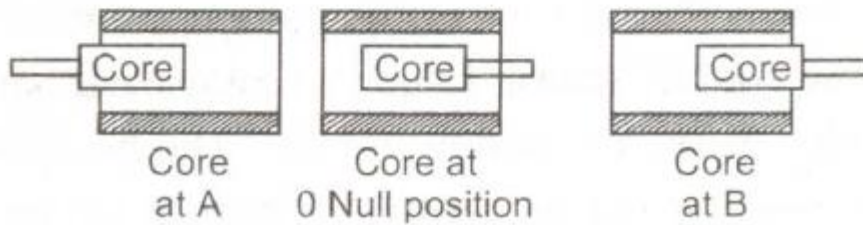
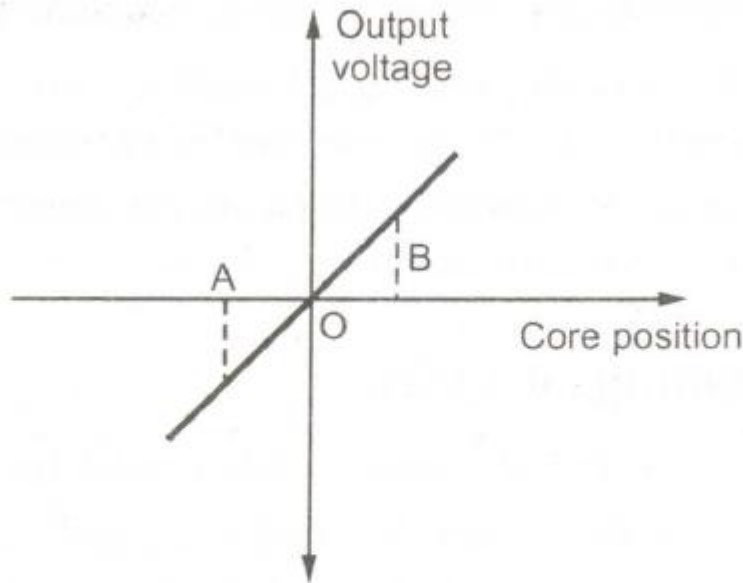

Output voltage of LVDT at different core positions

Recommended questions:

1. Explain LVDT [jan 05,07,09 jun 06,08]
2. What are the various classification of gauges?
3. Explain working of RTD. [jan 05,09]
4. What are strain gauges? [jun 06]

Unit:VIII**Hrs: 06****Syllabus:****Miscellaneous Topics**

- (a) **Transducers - II** –Piezoelectric transducer, photoelectric transducer, Photovoltaic transducer, Semiconductor photo devices, Temperature transducers-RTD, Thermocouple (Text 1: 13.15 to 13.20)
- (b) **Display devices:** Digital display system, classification of display, Display devices, LEDs, LCD displays (Text 1: 2.7 to 2.11)
- (c) Bolometer and RF power measurement using Bolometer (Text 1: 20.1 to 20.9)
- (d) Introduction to Signal conditioning (Text 1: 141)

Recommended readings:

1. “**Electronic Instrumentation**”, H. S. Kalsi, TMH, 2004
2. “**Electronic Instrumentation and Measurements**”, David A Bell, PHI / Pearson Education, 2006.

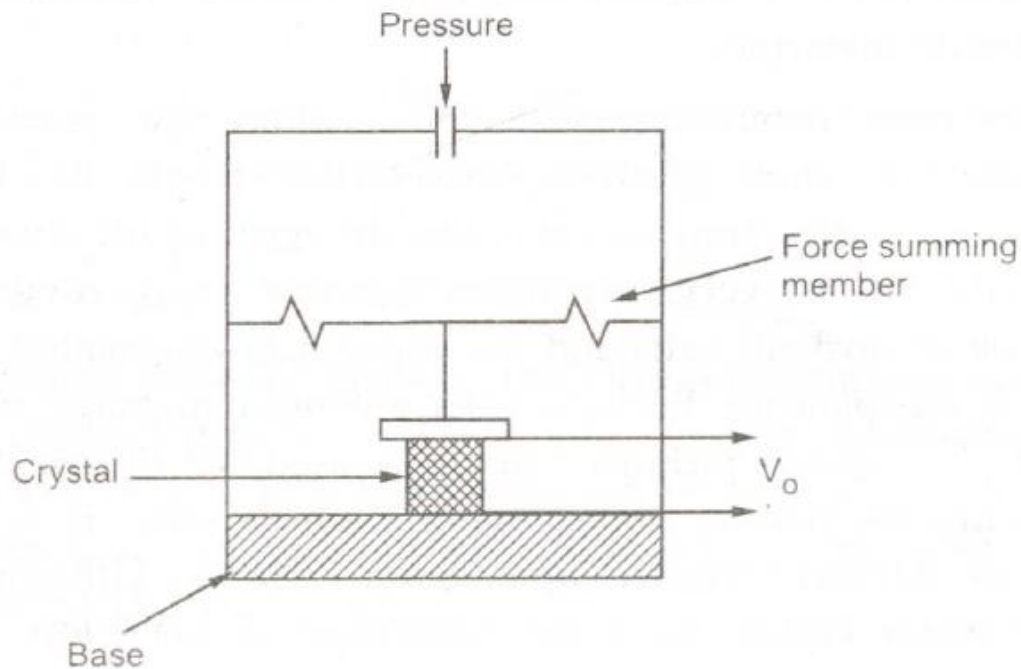
Unit 8:**Miscellaneous Topics****06 Hours****Transducers – II****Piezoelectric transducer:****Piezoelectric transducer**

A piezoelectric quartz crystal is hexagonal prism shaped crystal, which has pyramids at both ends. This is shown in the Fig. (a). The marking of co-ordinate axes are fixed for such crystals. The axis passing through the end points of pyramids is called optic axis or z axis. The axis passing through corners is called electrical axis or x axis while the axis passing through midpoints of opposite sides is called mechanical axis or y axis. The axes are shown in the

Photovoltaic cell:

Fig shows structure of photovoltaic cell. It shows that cell is actually a PN-junction diode with appropriately doped semiconductors. When photons strike on the thin p-doped upper layer, they are absorbed by the electrons in the n-layer; which causes formation of conduction electrons and holes. These conduction electrons and holes are separated by depletion region potential of the pn junction. When a load is connected

across the cell, the depletion region potential causes the photocurrent to flow through the load N

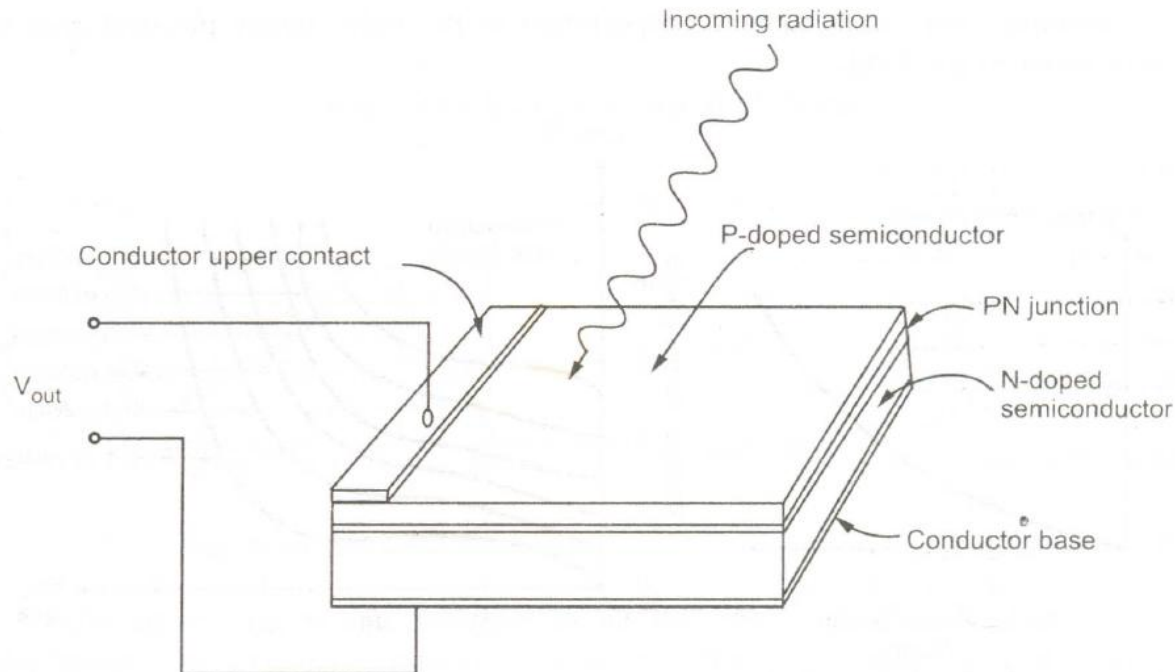

Phototransistor:

The photo transistor has a light sensitive collector to base junction. A lens is used in a transistor package to expose base to an incident light. When no light is incident, a small leakage current flows from collector to emitter called I_{eEO} , due to small thermal generation. This is very small current, of the order of nA. This is called a **dark current**.

When the base is exposed to the light, the base current is produced which is proportional to the light intensity. Such photoinduced base current is denoted as I_b ...The resulting collector current is given by,

$$I_C \approx h_{fe} I_b$$

The structure of a phototransistor is shown in the Fig. 9.15 (a) while the symbol is shown in the Fig.

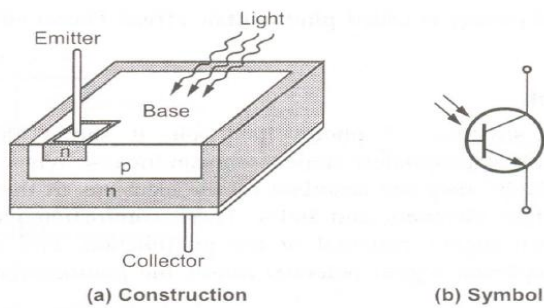

To generate more base current proportional to the light, larger physical area of the base is exposed to the light.

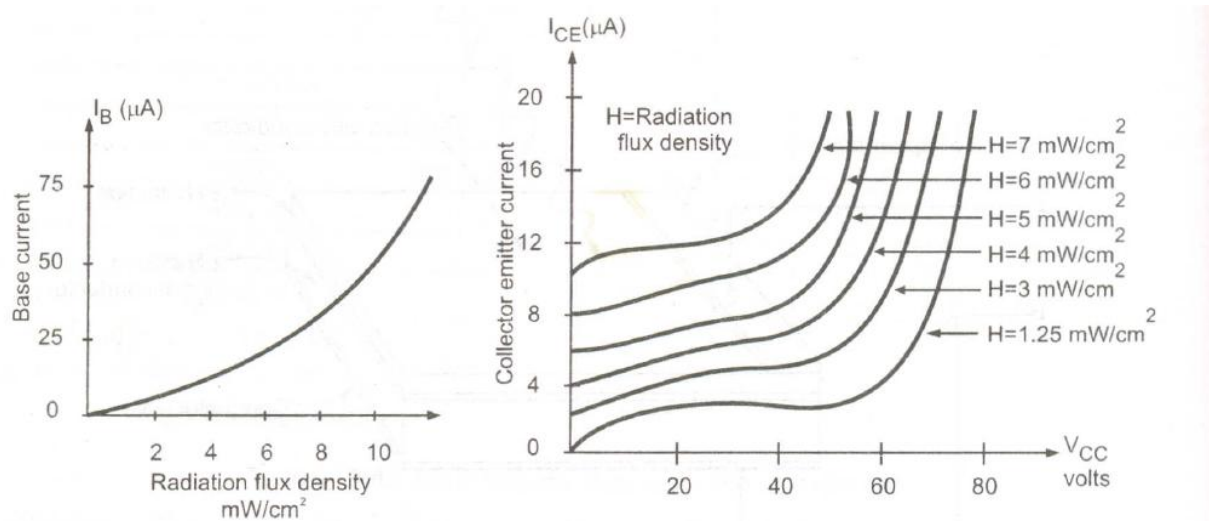

The fig .shows the graph of base current against the radiation flux density measured in mW/cm^2 . The Fig. (b) shows the collector characteristics of a phototransistor. As light intensity increases, the base current increases exponentially. Similarly the collector current also increases corresponding to the increase in the light intensity.

A phototransistor can be either a two lead or a three lead device. In a three lead device, the base lead is brought out so that it can be used as a conventional BJT with or without the light sensitivity feature.

In a two lead device, the base is not electrically available and the device use is totally light dependent. The use of phototransistor as a two lead device is shown in the Fig. (a) while the Fig. (b) shows the typical collector characteristic curves.

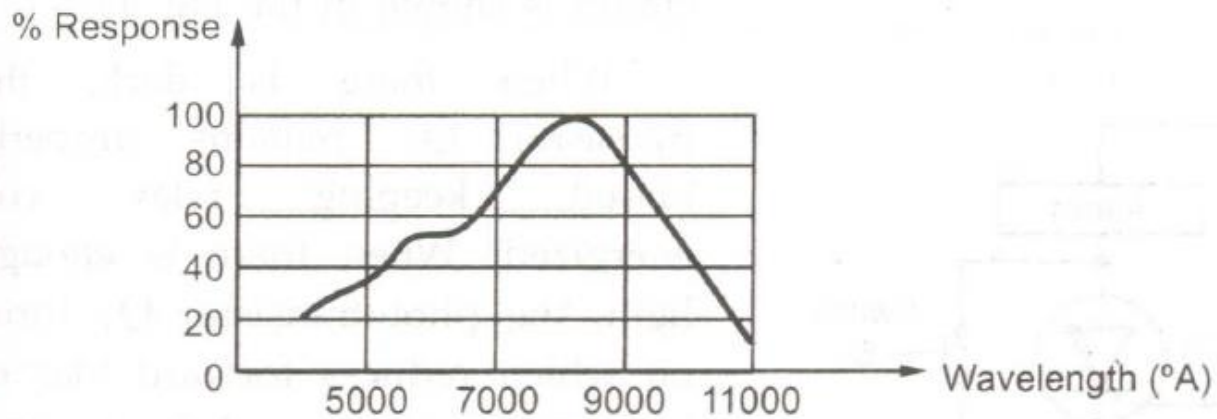
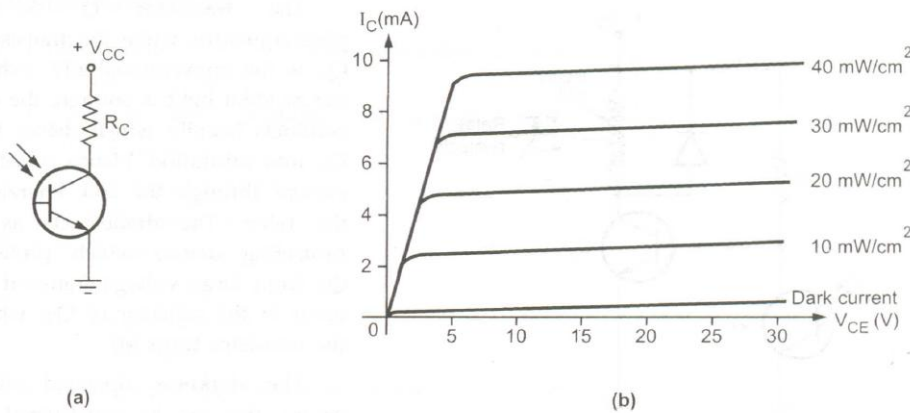

Spectral response

Each curve on the characteristic graph is related to specific light intensity. The collector current level increases corresponding to increase in the light intensity. In most of the applications the phototransistor is used as a two lead device.

The phototransistor is not sensitive to all the light but sensitive to light within a certain range. The graph of response against wavelength is called **spectral** response. A typical spectral response is shown in the Fig

Display devices:

Introduction :

In digital instruments, the output device of the instrument indicate the value of measured quantity using the digital display device. This digital display device may receive

the digital information in any form but it converts the information in decimal form. Thus the digital display device indicates the value in decimal digits directly. The basic element in a digital display is the display for a single digit. By grouping such displays for single digits, we can get multiple digit display. In general, digital display is classified as planar and non-planar display. A planar display is a display in which entire characters are displayed in one plane. A non-planar display is a display in which characters are displayed in different planes. In this chapter we will discuss different display devices. In general, LED's are most commonly used in the digital displays. The LED's have advantages such as low voltage, long life, high reliability, low cost, fast switching characteristics.

Classification of display:

In the digital electronic field, the most commonly used displays include cathode ray tube (CRT), light emitting diode (LED) and liquid crystal display (LCD), gas discharge plasma displays, electro-luminescent displays, incandescent displays.. liquid vapour displays etc.

A] Classification on the basis of conversion of electrical signal into the visible light :

There are two types of such displays.

- a) Active Displays - CRT, gas discharge plasma display, LED
- b) Passive Displays - LCD, electrophoretic image displays

B] Classification on the basis of applications :

- a) Analog Displays - Bar graph display, CRT
- b) Digital Displays - Nixie tubes, alphanumeric display, LED.

C] Classification on the basis of physical dimensions and sizes :

- a) Symbolic Displays - Alphanumeric, Nixie tube, LED
- b) Console Displays - LED, CRT
- c) Large Screen Displays - Enlarged projectors

D] Classification on the basis of display format

- a) Direct View Type (Flat Panel) - Segmental display, dot matrix
- b) Stacked Non-planar Type - Nixie tube

E] Classification on the basis of resolution

- a) Simple single element indicator
- b) Multielement displays

Light Emitting Diodes (LED)

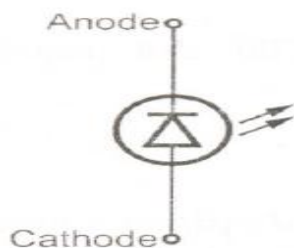

The LED is an optical diode, which emits light when forward biased. The Fig. shows the symbol of LED which is similar to p-n junction diode apart from the two arrows indicating that the device emits the light energy.

Basic Operation:

Whenever a p-n junction is forward biased, the electrons cross the p-n junction from the n-type semiconductor material and recombine with the holes in the p-type semiconductor material. The free electrons are in the conduction band while the holes are present in the valence band. Thus the free electrons are at higher energy level with respect to the holes. When a free electron recombines with hole, it falls from conduction band to a valence band. Thus the energy level associated with it changes from higher value to lower value. The energy corresponding to the difference between higher level and lower level is released by an electron while travelling from the conduction band to the valence band. In *form of diodes, this energy released is in the form of heat. But LED's are made up of some special material which release this energy in the form of photons which emit the light energy. Hence such diodes are called light emitting diodes.*

Construction of LEDs:

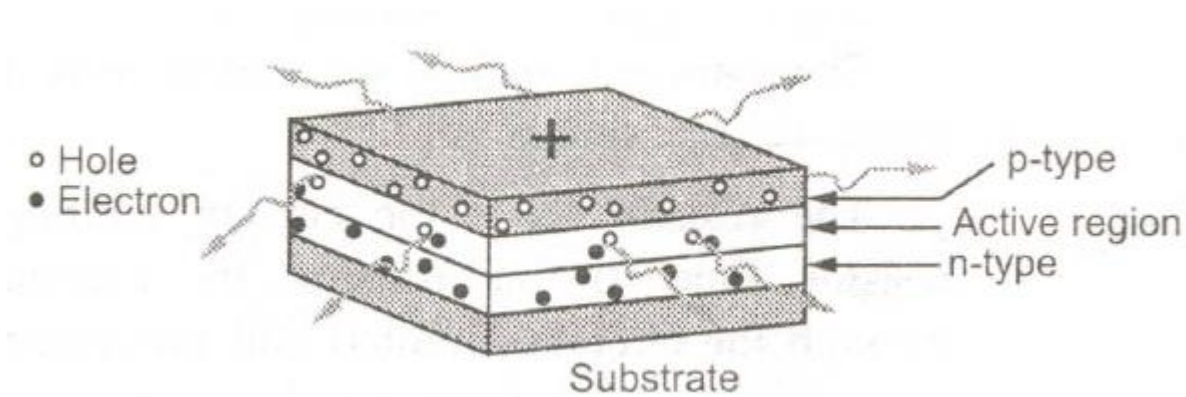

One of the methods used for the LED construction is to deposit three semiconductor layers on the substrate as shown in the Fig. In between p type and n type, there exists an active region.

LED Driver Circuit:

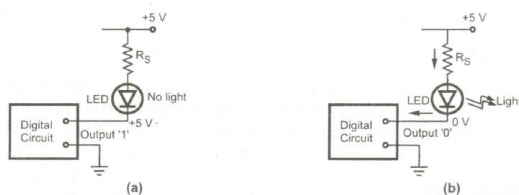

The output of a digital circuit is logical i.e. either '0' or '1'. The '0' means low while '1' means high. In the high state the output voltage is nearly 5 V while in low state, it is almost 0 V. If LED is to be driven by such digital circuit, it can be connected as shown in the Fig. 10.10. When

output of digital circuit is high, both ends of LED are at 5 V and it can not be forward biased hence will not give light. While when output of digital circuit is low, then high current will flow through LED as it becomes forward biased, and it will give light.

To improve the brightness of display, a dynamic display system is used. In this, the LEDs are not lit continuously but are sequentially lit by scanning in a "vertical strobe" or "horizontal strobe" mode. This is similar to "running lights" used in modern advertisements.

In the vertical strobe mode, a single row is selected at a time, the appropriate LEDs are energized in that row, and then the signal is applied to next row. On the contrary, in horizontal strobe mode, a single column is selected at a time.

Alphanumeric displays using LEDs employ a number of square and oblong emitting areas, arranged either as dot matrix or segmented bar matrix.

Alphanumeric LEDs are normally laid out on a single slice of semiconductor material, all the chips being enclosed in a package, similar to an IC, except that the packaging compound is transparent, and not opaque,

Liquid Crystal Displays (LCDs):

The liquid crystals are one of the most fascinating material systems in nature, having properties of liquids as well as of a solid crystal. The term liquid crystal refers to the fact that these compounds have a crystalline arrangement of molecules, yet they flow like a liquid. Liquid crystal displays do not emit or generate light, but rather alter externally generated illumination. Their ability to modulate light when electrical signal is applied has made them very useful in flat panel display technology.

The crystal is made up of organic molecules which are rod-like in shape with a length of $20 \text{ \AA} - 100 \text{ \AA}$. The orientation of the rod like molecule defines the "director" of the liquid crystal. The different arrangements of these rod-like molecules lead to three main categories of liquid crystals.

1. Smectic
2. Nematic
3. Cholesteric

Types of LCDs:

There are two types of liquid crystal displays (LCDs) according to the theory of operation: 1. Dynamic scattering 2. Field effect.

Dynamic Scattering Type LCD:

Fig. shows the construction of a typical liquid crystal display. It consists of two glass plates with a liquid crystal fluid in between. The back plate is coated with thin transparent layer of conductive material, where as front plate has a photoetched conductive coating with seven segment pattern as shown in Fig

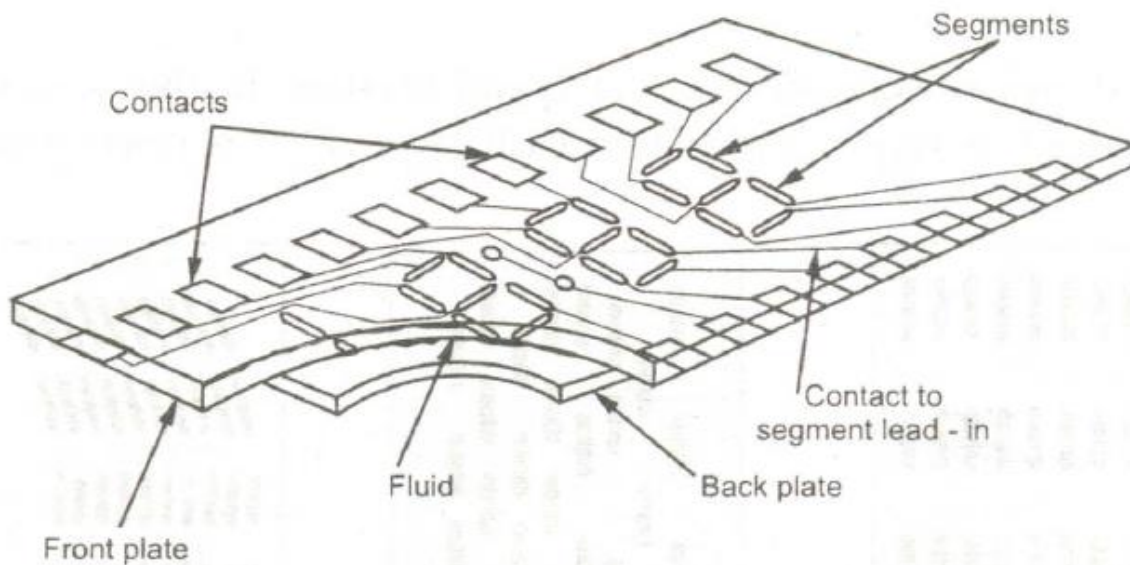

Field Effect Display:

In these displays nematic liquid crystals are used. Fig shows operation of field effect liquid crystal display with nematic crystals. It consists of two glass plates, a liquid crystal fluid, polarizers and transparent conductors. The liquid crystal fluid is sandwiched between two glass plates. Each glass plate is associated with light polarizer. The light polarizers are placed at right angle to each other. In the absence of electrical excitation, the light coming through the front polarizer is rotated through 90° in the fluid and passed through the rear polarizer. It is then reflected to the viewer by the back mirror as shown in Fig. (a).

On the application of electrostatic field, the liquid crystal fluid molecules get aligned and therefore light through the molecules is not rotated by 90° and it is absorbed by the rear polarizer as shown in Fig. (b). This causes the appearance of dark digit on a

light background as shown in Fig. (c).

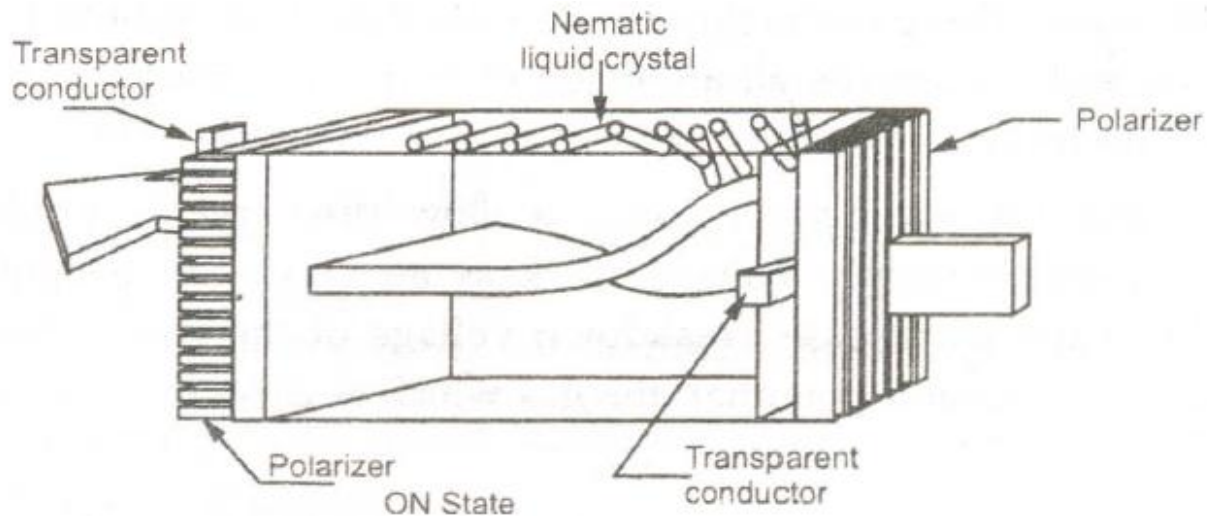

(a) Field effect display "ON state"

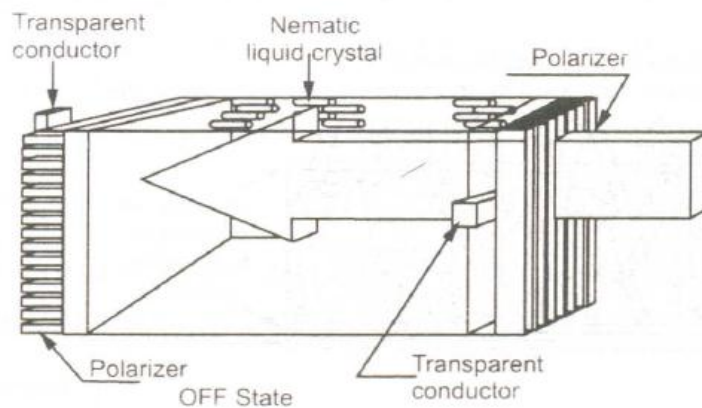

(b)



(c)

Advantages of LCDs:

1. Less power consumption
2. Low cost
3. Uniform brightness with good contrast

Nixie tubes:

The operation of this display is based on the principle that under breakdown

condition, a gas near cold cathode gas filled tube emits light. The cold cathode indicators are called Nixie Tubes. These are based on the principle of glow discharge in a cold cathode gas filled tubes. The construction of the nixie tube is as shown in the Fig..It consists 10 cathode and one anode, all are made of thin wires. But only difference is anode is in the form of thin frame.

When a gas near cathode breaks down, a glow discharge is produced. The gauze electrodes with a positive supply voltage work as an anode. In general this voltage is selected greater than the worst case breakdown voltage of the gas within tube. When the cathode is connected to ground potential, the gas which is close to a cathode glows.

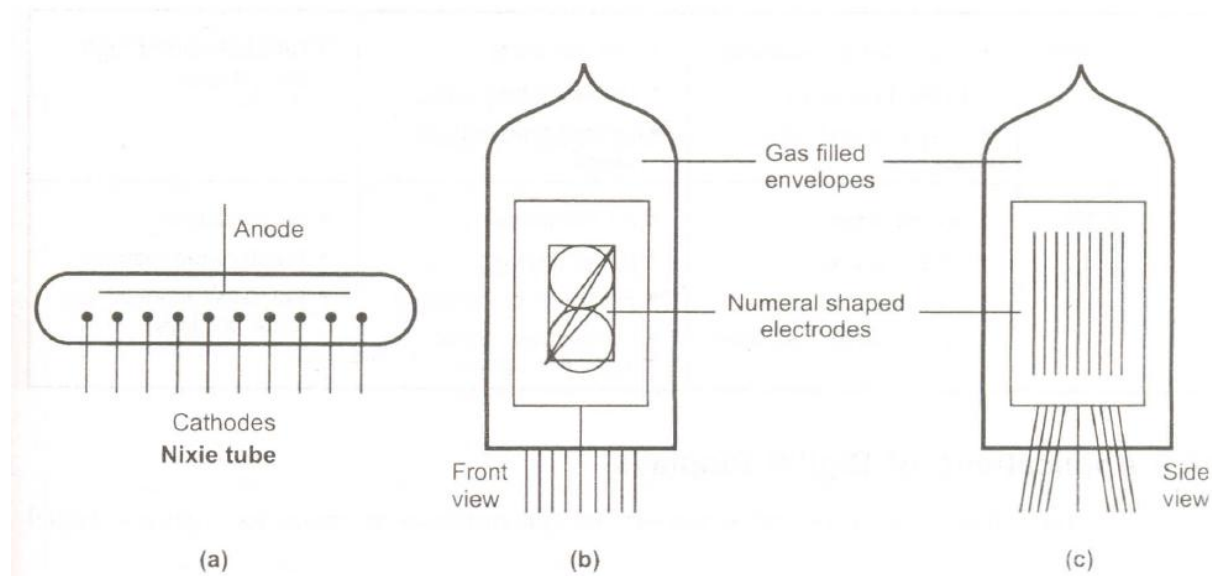

Bolometer and RF power measurement using Bolometer:

Introduction:

In many industrial applications, the measurement of power is very important aspect. The considerations for the measurement of power are different for different frequency ranges. The direct measurement of power is very difficult in A.F. and RF. ranges. But it is convenient to measure voltage or current in A.F. and RF. ranges. Hence indirectly power is obtained by using relation,

$$P = \frac{V^2}{R} = I^2 \cdot R$$

If we consider a frequency range well above RF. range, then it is a microwave frequency range. In the microwave ranges, the parameters such as voltage, current, impedances are distributed throughout the length of the circuit. Moreover these parameters change their values with the variation in geometry of the circuit. So it is difficult to measure voltage and current at microwave frequency ranges, but the power can be measured accurately. Thus the direct measurement of power is possible with actual load replaced by dummy load

Power measurement at audio frequency:

The power measurement at audio frequencies (upto 20 kHz) is carried out using a substitute load for the actual load. This is called dummy load. The dummy load is generally a resistance whose value is known. The dummy load is connected at the output of the device under test. The voltage across the dummy load or current through the dummy load is measured using instruments like rectifier, thermocouple type meters which can work at high frequencies. As the resistance of dummy load is known, the output power can be measured as,

$$P = \frac{V^2}{R} = I^2 R$$

where

P = Output power to be measured

V = Voltage across dummy load

I = Current through dummy load

R = Resistance of dummy load

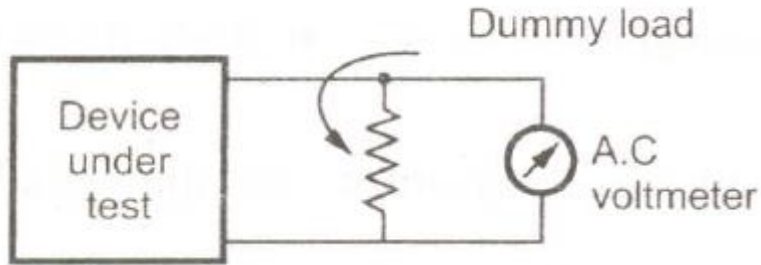

The resistance of dummy load is approximately equal to the output impedance of the device under test. It is connected across the device under test. The resistance R should be able to dissipate the power applied to it. The A.C. voltmeter which is a high resistance rectifier type instrument is used to measure voltage across the dummy load. As the dummy load resistance R is fixed and known then power is V^2 / R where V is voltage measured by a.c. voltmeter. In such a case the scale of the a.c. voltmeter can be calibrated to measure the power output of the device under test. This scale is calibrated in decibels as the power measured at audio frequency range is generally specified in decibels (dB).

Power measurement at radio frequency:

The method of using a dummy load and a voltmeter can be used at radio frequencies upto 500 MHz also. In such a case, the voltmeter and load resistor are usually combined into a single absorption type power meter as shown in the Fig.

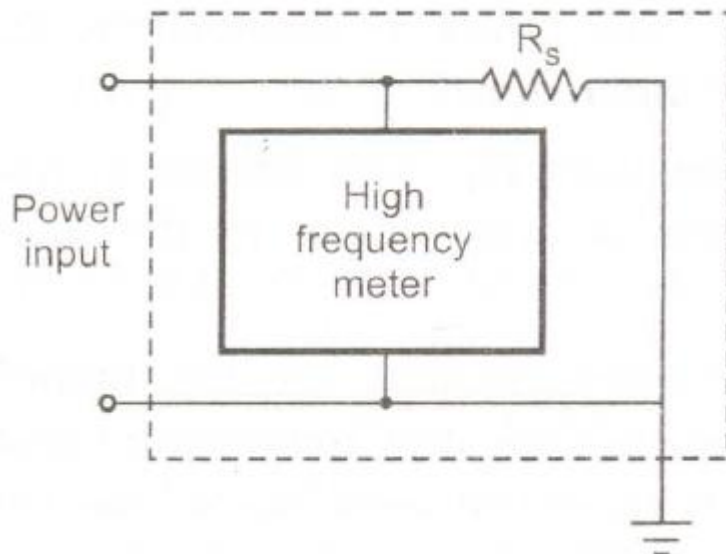

The resistance R_s is so designed that its value remains constant over the entire range of frequencies of interest. The voltmeter is a high frequency meter which is capable of responding to high frequency signals with high accuracy. The power is calculated by using the basic relationship as,

$$P = \frac{V_s^2}{R_s}$$

where $V_s =$ Voltmeter reading

In practice the standard resistors are available which have constant value for frequencies ranging from d.c. to 4 GHz. This type of power meter is used to measure power below 500 MHz only.

To measure power at high frequencies from 500 MHz to 40 GHz two special type of absorption meters are popularly used. These meters are,

1. Calorimeter power meter
2. Bolometer power meter

Both these meters use the sensing of heating effects caused by the power signal to be measured.

Introduction to Bolometer power meter:

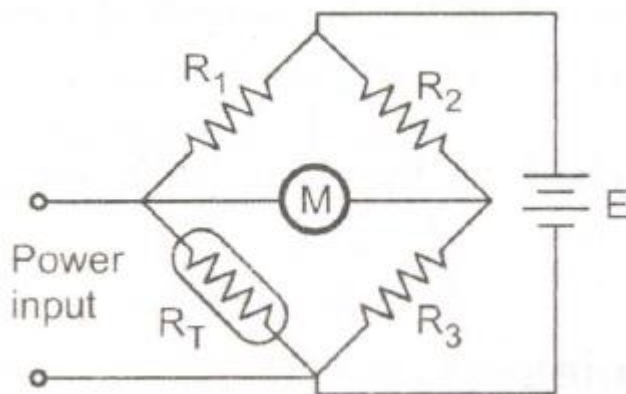

The Bolometer power meter basically consists of a bridge called Bolometer bridge. One of the arms of this bridge consists of a temperature sensitive resistor. The basic bridge used in Bolometer power meter is shown in the Fig. The high frequency power input is applied to the

temperature sensitive resistor R_T . The power is absorbed by the resistor and gets heated due to the high frequency power input signal.

This heat generated causes change in the resistance R_T . This change in resistance is measured with the help of bridge circuit which is proportional to the power to be measured.

The most common type of temperature sensitive resistors are the thermistor and barretter. The thermistor is a resistor that has large but negative temperature coefficient. It is made up of a semiconductor material. Thus its resistance decreases as the temperature increases. The barretter consists of short length of fine wire or thin film having positive temperature coefficient. Thus its resistance increases as the temperature increases. The barretters are very delicate while thermistors are rugged. The bolometer power meters are used to measure radio frequency power in the range 0.1 to 10 mW.

In modern bolometer power meter set up uses the differential amplifier and bridge [or] an oscillator which oscillates at a particular amplitude when bridge is unbalanced. The modern bolometer power meter circuit is shown in the Fig.

Initially when temperature sensitive resistor is cold, bridge is almost balance. With d.c. bias, exact balance is achieved. When power input at high frequency is applied to R_T , it absorbs power and gets heated. Due to this its resistance changes causing bridge unbalance. This unbalance is in the direction opposite to that of initial cold resistance. Due to this, output from the oscillator decreases to achieve bridge balance.

The electronic voltmeter measures the power decrease from oscillator. It indicates this as an increase in power due to high frequency power input.

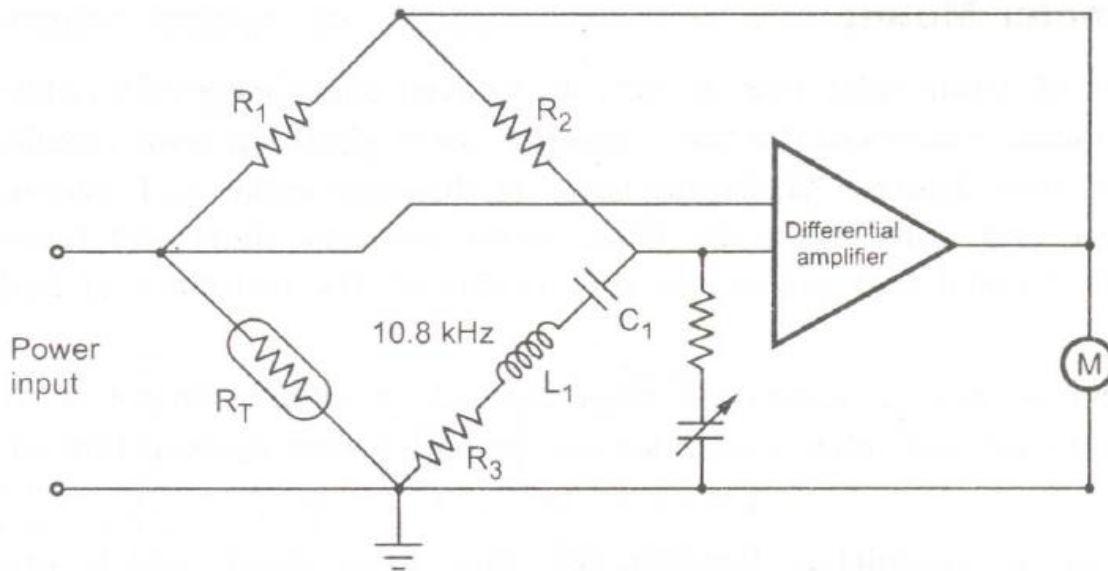

Bolometer Elements

Basically a bolometer is very short thin wire. A wire with positive temperature coefficient of resistance is called Barreter. Similarly a wire with negative temperature coefficient of resistance is called thermistor. Both are able to measure small power of the order of microwatts.

A metal wire bolometer i.e. barreter has a positive temperature coefficient of resistance (PTC). It is operated at powers which heat wire upto 100 - 200°C. The metal wire bolometer consists a short length of Wollaston wire. Its external sheath is etched away so that its thin metal core consisting platinum alloy is exposed. The length of such wires IS extremely small (typically 2.5 mm). The diameter of such wires range from 1 to 3 micron. For perfect match with the R.F. line, resistance of the depleted region is adjusted suitably for bias with low powers. This value is generally equal to the characteristic impedance. For R.F. measurements, the minute beads of ceramic such as semiconductor mixtures of metal oxides with large negative temperature coefficient of resistance (NTC) are used as thermistors. Such beads consists two platinum alloy wires. Then the bead is sintered and coated with glass film. The beads are capsuled in glass envelope.

To achieve perfect impedance matching between the bolometer element and the R.E line, the bolometer element is made of very small size. Such element responses equally

well to low frequency and R.F. power.

In most of the elements, the diameter of wire is selected equal to the skin depth of R.F. current at highest frequency of operation. Typically d.c. and R.F. resistivities of the element are same. The reactive component is made negligible for such elements. As the maximum cross-section area of the bolometer wire is inversely proportional to the highest frequency of operation and conductivity of the bolometer material, the wires of the bolometer are ultra thin at microwave frequency.

Bolometer mount:

It consists of a thin mica disc. It consists sprayed silver electrodes. There are through silver plated holes which enables the contact of outer electrode with circular electrode on opposite side. Two depleted Wollatone wires of diameter equal to 1 micron are mounted between centre and outer electrode. These wires are very short and typically of length 1 - 2 mm. With normal bias power, for d.c. conditions, the resistance of both the wires is about 100 Ω . The holder is used to clamp the mica disc which makes contact of upper electrode with the metal case and other electrodes are insulated from co-axial line as shown in the Fig. The circuit is completed through the thin mica sheet which provides bypass capacitance.

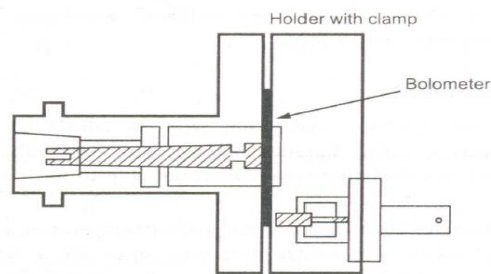

(a) Bolometer mount

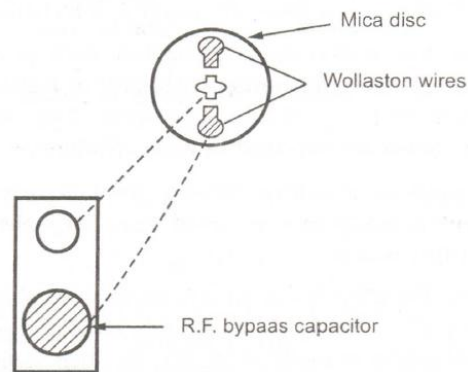

(b) Bolometer element

Bolometer Bridge for Measurement of Power

The measurement of unknown RF. power is done by using bolometer bridge in which a known A.F. power is superimposed on unknown RF. power. The schematic of power measurement using bolometer bridge is as shown in the Fig.

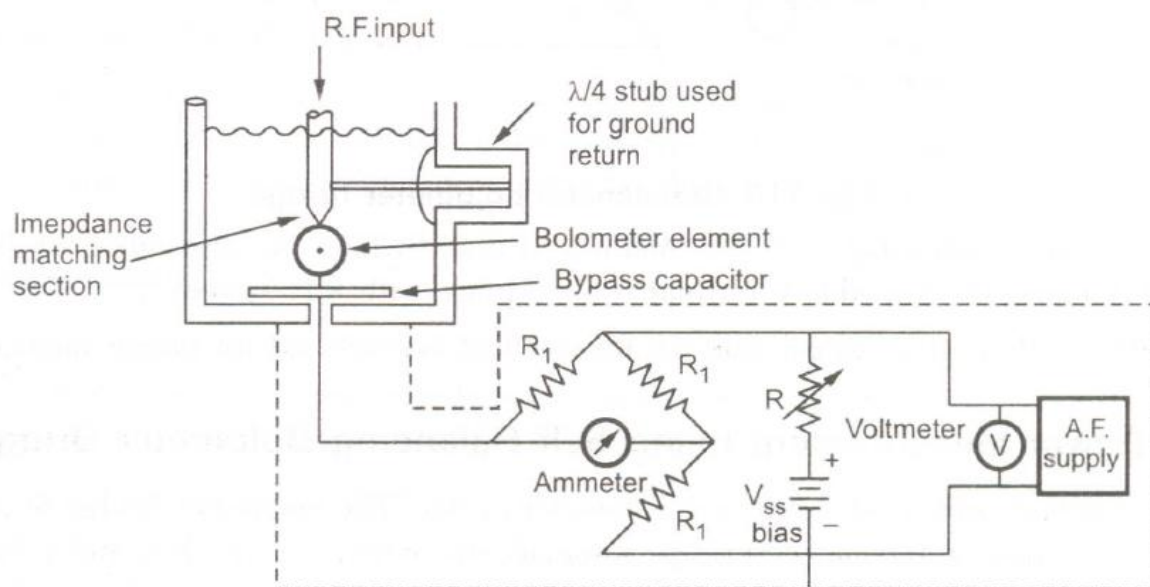

Using the variable resistance R and the d.c. bias voltage V_{ss} , the current is adjusted till bolometer element is heated and its resistance equals R_1 . With this value, bridge achieves balance condition. The test RF. input is switched off which again unbalances bridge. To achieve the balance condition again, the A.F. voltage is increased till RF. power equals

$$\text{R.F. power} = \frac{V_2^2 - V_1^2}{4 R_1}$$

Power measurement using self balancing bolometer

This method uses a self balancing bolometer bridge. The bolometer bridge is called self balancing because it rebalances bridge automatically whenever the bolometer element is supplied with unknown K.F. power. A typical circuit diagram for self balancing bolometer bridge is as shown in the Fig.

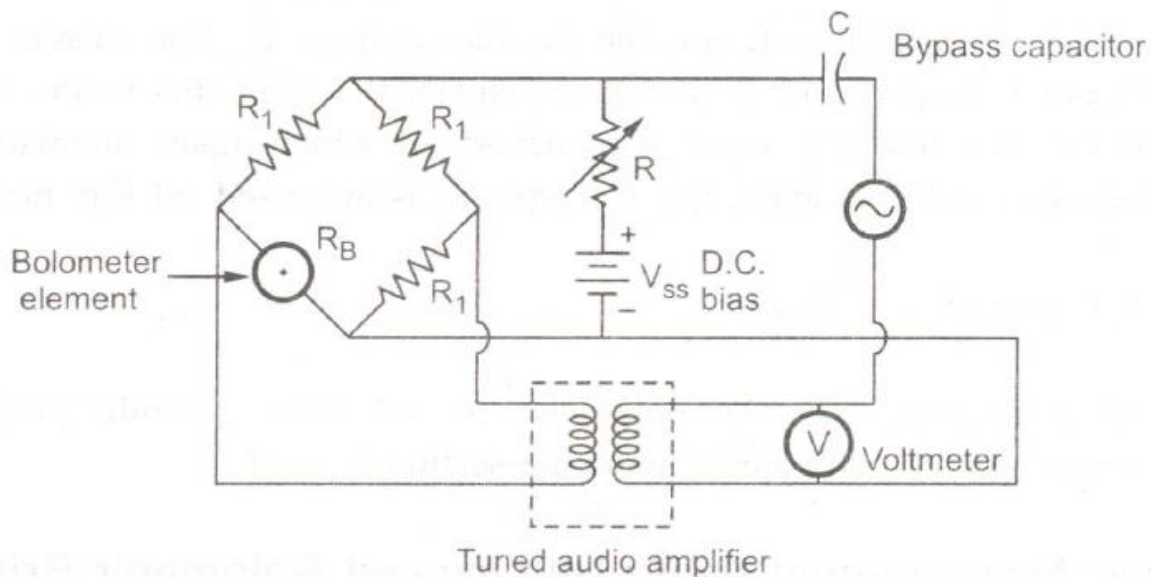

This method uses an audio amplifier which is high gain frequency selective amplifier. The input and output terminals of the amplifier are coupled through bolometer bridge. The feedback used in amplifier produces sustained A.F. oscillations and also maintains the resistance of the bolometer at a fixed value required for balanced condition.

When the supply is switched ON, the bolometer bridge becomes unbalance. But due to the oscillations produced with a proper phase, the bridge becomes almost balanced. The gain of the tuned audio amplifier plays important role. That means if the gain of the amplifier is higher then the bolometer bridge balances closely.

When the K.F. power is dissipated in the bolometer element, the bridge again becomes unbalanced. But again the output voltage of amplifier readjusts the balancing condition automatically by restoring the value of bolometer resistance. Note that the amount of A.F. power level reduces in the bolometer is equal to the unknown applied K.F. power. The

voltmeter V measures A.F. voltage and it is calibrated in such a way that the magnitude of the K.F. power is read directly. A typical self balancing bolometer bridge circuit can be used for measurement of several power ranges from 0.1 mW to 100 mW. In such circuit, the bolometer used has a resistance with five selected values from 50 Ω to 250 Ω within + 10 % range.

Introduction to Signal conditioning:

Introduction:

The primary objective of industrial process control is to control physical parameters such as temperature, pressure, flow rate, level, force, light intensity, and so on. The process control system is designed to maintain these parameters near some desired specific value. As these parameters can change either spontaneously or because of external influences, we must constantly provide corrective action to keep these parameters constant or within the specified range.

To control the process parameter, we must know the value of that parameter and hence it is necessary to measure that parameter. **In** general, a measurement refers to the transduction of the process parameter into some corresponding analog of the parameter, such as a pneumatic pressure, an electric voltage, or current. A **transducer** is a device that performs the initial measurement and energy conversion of a process parameter into analogous electrical or pneumatic information. Many times further transformation or signal enhancement may be required to complete the measurement function. Such processing is known as **signal conditioning**.

Electronic aided measurement:

For any measurement system., the first stage detects the physical quantity to be measured this is done with the help of suitable transducer. The next stage converts this signal into an electrical form. The second stage is used to amplify the converted signal such that it becomes usable and suitable for the last stage which is signal conditioning stage. The last stage includes various elements used for different purposes such as indicating, recording, displaying, data processing and control elements.

A typical electronic aided measurement system is as shown in the Fig

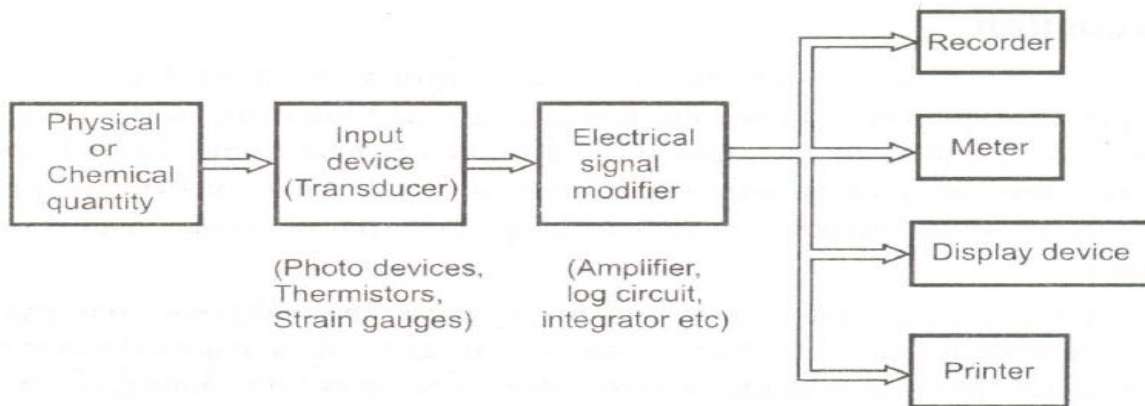

The first stage is the input device which is nothing but a transducer which converts measurand into an usable form i.e. electrical signal. In other words, the quantity measured is encoded as an electrical signal. The next stage modifies the electrical signal in the form suitable for the output or read-out devices. Generally the most frequently used electronic circuits are amplifiers, with parameter adjustments and automatic compensation circuits specially used for temperature variation. of the input device and non-linearities of the input device. The output is obtained from read-out devices such as meter, recorder, printer, display units etc.

In general, the quantity which is measured by using transducer can be encoded in different ways. For example, as a physical or chemical quantity or property, as a characteristics of the electrical signal, as a number. The property or different characteristics used to represent a data is called **data** domain.

The electronic aided measurement system represents the measurement of physical quantity faithfully in the analog or digital form of it obtained from the signal conditioning circuits. For passive transducers, the signal conditioning circuit mainly' includes excitation and amplification circuitry, while for active transducers, only amplification circuitry is needed and the excitation is not needed. Depending on the type of the excitation either a.c. or d.c. source, we have a.c. signal conditioning system and d.c. signal conditioning system.

D.C. Signal Conditioning System:

The block diagram of d.c. signal conditioning system is shown in the Fig

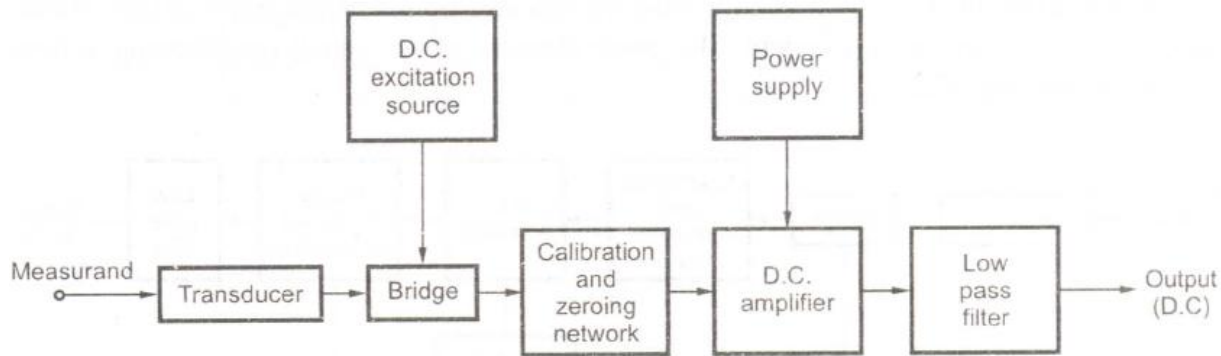

The resistance transducers are commonly used for the d.c. systems. The resistance transducers like strain gauge forms one or more arms of a wheatstone bridge circuit. A separate d.c. supply is required for the bridge. The bridge is balanced using potentiometer and can be calibrated for unbalanced conditions. This is the function of Calibration and zeroing network. Then there is d.c. amplifier which also requires i..l separate d.c. supply.

The d.c. amplifier must have following characteristics:

1. Balanced differential inputs.
2. High common mode rejection ratio. (CMRR)
3. High input impedance.
4. Good thermal and long term stability.

The d.c. system has following advantages:

1. It is easy to calibrate at low frequencies.
2. It is able to recover from an overload condition.

But the main disadvantage of d.c. system is that it suffers from the problems of drift.

The low frequency spurious unwanted signals are available alongwith the required data signal. For overcoming this, low drift d.c. amplifiers are required.

The output of d.c. amplifier is given to a low pass filter. The function of low pass filter is to eliminate unwanted high frequency components or noise from the required data signal. Thus the output of low pass filter is the required data signal. Thus the output of low pass filter is the required d.c. output from the d.c. signal conditioning system.

The applications of such system are in use with common resistance transducers such as potentiometers and resistance strain gauges.

A.C. Signal Conditioning System:

The limitation of d.c. signal conditioning system can be overcome upto certain extent, using a.c. signal conditioning system. The block diagram of a.c. signal conditioning system is shown in the Fig

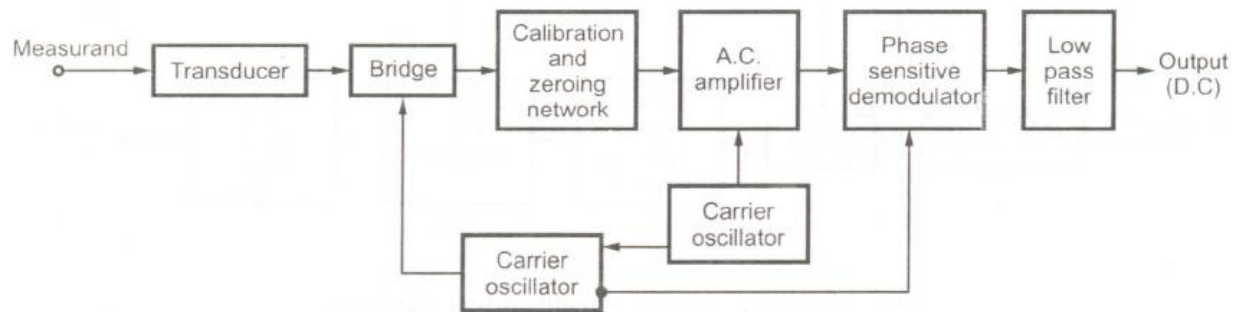

This is carrier type a.c. signal conditioning system. The transducer used is variable resistance or variable inductance transducer. The carrier oscillator generates a carrier signal of the frequency of about 50 Hz to 200 kHz. The carrier frequencies are higher and are at least 5 to 10 times the signal frequencies.

The bridge output is amplitude modulated carrier frequency signal. The a.c. amplifier is used to amplify this signal. A separate power supply is required for the a.c. amplifier. The amplified signal is demodulated using phase sensitive demodulator. The advantage of using phase sensitive demodulator is that the polarity of d.c. output indicates the direction of the parameter change in the bridge output.

Unless and until spurious and noise signals modulate the carrier, they will not affect the data signal quality and till then are not important. Active filters are used to reject mains frequency pick up. This prevents the overloading of a.c. amplifier. Filtering out of carrier frequency components of the data signal is done by phase sensitive demodulator.

The applications of such system are in use with variable reactance transducers and for the systems where signals are required to be transmitted through long cables, to connect the transducers to the signal conditioning system.

Further processing of signals is required which includes linear and nonlinear operations

This type of signal conditioning includes the circuits like sample and hold, multiplexers,

analog to digital converters etc.

\

Recommended Questions:

1. *Discuss different considerations of power measurement in various frequency ranges.[jun 07, 09]*
2. *Explain briefly the techniques used for power measurement at high frequencies.*
3. *Write a note on power measurement at audio frequency.[jan 05,06, jun 07, 08,]*
4. *What are basic requirements of load & Write different forms of the dummy load satisfying above requirements.*
5. *Explain R.F. power measurement.[jan 09, jun 07]*
6. *Write notes on :1) Bolometer power meter 2) Bolometer element 3) Bolometer mount.*
7. *Explain power measurement using bolometer bridge. Draw neat schematic diagram.[jan 07,09 jun 05,06,09]*
8. *Explain power measurement using unbalanced bolometer bridge.*
9. *What is meant by signal conditioning ? Why is it necessary ? [jan 08,09 jun 05,07]*
10. *Write a note on electronic aided measurement system.*
11. *Explain d.c. signal conditioning system with the help of block diagram.*
12. *Draw block diagram of signal conditioning system. Explain briefly.[jan 06,07,09]*

