

---

**Management Concepts & Organisational Behaviour**

---

**Unit – I**

Nature of Management - Social Responsibility Ties of Business - Manager and Environment Levels in Management - Managerial Skills - Planning - Steps in Planning Process - Scope and Limitations - Short Range and Long Range Planning - Flexibility in Planning - Characteristics of a sound Plan - Management by Objectives (MBO) - Policies and Strategies - Scope and Formulation - Decision Making - Techniques and Processes.

**Unit-II**

Organising - Organisation Structure and Design - Authority and Responsibility Relationships - Delegation of Authority and Decentralisation - Interdepartmental Coordination - Emerging Trends in Corporate Structure, Strategy and Culture - Impact of Technology on Organisational design - Mechanistic vs Adoptive Structures - Formal and Informal Organisation.

**Unit – III**

Perception and Learning - Personality and Individual Differences - Motivation and Job Performance - Values, Attitudes and Beliefs - Stress Management - Communication Types-Process - Barriers - Making Communication Effective.

**Unit – IV**

Group Dynamics - Leadership - Styles - Approaches - Power and Politics - Organisational Structure - Organisational Climate and Culture - Organisational Change and Development.

**Unit – V**

Comparative Management Styles and approaches - Japanese Management Practices Organisational Creativity and Innovation - Management of Innovation - Entrepreneurial Management - Benchmarking - Best Management Practices across the world - Select cases of Domestic & International Corporations - Management of Diversity.



## UNIT - I

---

### Lesson - 1 : Nature Of Management

---

#### Objectives

*After reading this lesson, you should be able to:*

- Understand The Nature Of Management;
- Identify And Describe The Functions Of Management;
- Understand The Social Responsibilities Of Business; And
- Appreciate The Interests Of Various Stakeholders In The Business.

#### Lesson Outline

- Management As Science
- Management As Art
- Management As Profession
- Professionalisation Of Management In India
- Functions Of Management
- Review Questions

## **Introduction:**

Take a close look at the society around you. You would find the existence of several organizations. To mention a few, the business organizations that produce goods or services, hospitals, religious and social institutions like charities, schools, colleges and universities. All these organizations exist to achieve pre-determined objectives. They affect our lives in many ways. Though there are vast differences in their functioning and approaches, they all strive to achieve certain objectives. It must also be noted that organizations cannot achieve the objectives effortlessly. They are achieved through systematic effort. Several activities have to be performed in a cohesive way. In the absence of systematic and cohesive performance of the activities to achieve the objectives, it is no wonder that the resources of organizations would be underutilized. As such it is the function of the management to facilitate the performance of activities such that the accomplishment of the objectives becomes possible.

## **Meaning of Management**

Management is understood in different ways by different people. Economists regard it as a factor of production. Sociologists see it as a class or group of persons while practitioners of management treat it as a process. For our understanding, management may be viewed as what a manager does in a formal organization to achieve the objectives. In the words of Mary Parker Follet management is *“the art of getting things done through people”*. This definition throws light on the fact that managers achieve organizational goals by enabling others to perform rather than performing the tasks themselves.

Management encompasses a wide variety of activities that no one single definition can capture all the facets of management. That is why, it is often said that there are as many definitions of management as there are authors in the field. However, the definition given by James A.F. Stoner covers all the important facets of management.

According to him:

*“Management is the process of planning, organizing, leading and controlling the efforts of organization members and of using all other organizational resources to achieve stated organizational goals”*.

***The definition suggests:***

- ▶ Management is a continuous process;
- ▶ Several interrelated activities have to be performed by managers irrespective of their levels to achieve the desired goals;
- ▶ Managers use the resources of the organization, both physical as well as human, to achieve the goals;
- ▶ Management aims at achieving the organisation's goals by ensuring effective use of resources in the best interests of the society.

It is evident that the emphasis is on achieving the objectives by using material, machinery, money and the services of men. These inputs are drawn from the environment in which the organization exists. Whether an organization is engaged in business or non-business, the various inputs are judiciously used to produce the outputs. The process involving the conversion of inputs into outputs is common to all organizations and is shown in figure 1.1

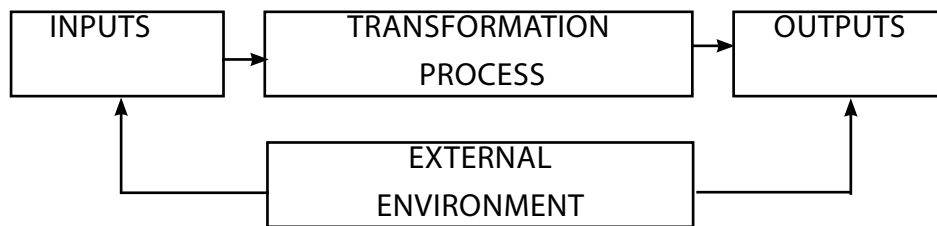

**Figure 1.1: INPUT – OUTPUT MODEL**

Depending on the nature of business or activity that a firm is engaged in, the output of the firm may be a physical product or service. Since a business organization is an economic entity, the justification for its existence lies in producing goods and services that satisfy the needs of the people. As could be seen in the figure, the organization draws several inputs from the environment, converts them into products or services and sends them back to the environment. Environment here means the larger system, i.e., the society in which the firm exists. Therefore, it goes without saying that how effectively the goods and services are produced is a matter of concern for any society, given the scarcity of resources. Effective management therefore plays a crucial role in this context.

## Nature of Management

The practice of management is as old as human civilization. In fact, much of the progress of mankind over the centuries may be attributed to the effective management of resources. The irrigation systems, the public utilities, the construction of various monuments like Taj Mahal, and the Egyptian Pyramids of the bygone era amply demonstrate the practice of management in the olden days. Similarly, the ancient civilizations of Mesopotamia, Greece, Rome and Indus-valley displayed the finest practices of management of those periods. However, the study of management in a systematic way as a distinct body of knowledge is only of recent origin. That is why, management is often described as “*oldest of the arts and youngest of the sciences*”. Thus, the practice of management is not new. It has been practiced for thousands of years. But the science part of it ‘*the systematic body of knowledge*’ is, no doubt, a phenomenon of the present century.

The traditional management practices remained quite stable through the centuries until the birth of industrial revolution in the mid 18th century. The industrial revolution brought about the substitution of machine power for man power through several scientific inventions. As a result, within a few decades, the landscape of industrial activity had undergone a metamorphic change. Man’s quest for new ways of doing things, coupled with his ingenuity in adopting the scientific and technological inventions in the production of goods and services resulted in:

- ▶ Mass production in anticipation of demand;
- ▶ Advent of corporate form of organization which facilitated large scale production;
- ▶ Spectacular improvements in the transport and communication facilities;
- ▶ Increased competition for markets;
- ▶ The establishment of new employer – employee relationship; and
- ▶ A radical change in the aspirations and expectations of the various stakeholders of business.

Industrial revolution had thus sown the seeds of modern management. The early scientific enquiries into the practice of management began. Despite the growing importance of management

as an academic discipline immensely contributing to the quality of human life, it is disheartening to know that the concept is still clouded by certain misconceptions. No doubt, management as an academic body of knowledge has come a long way in the last few decades. It has grown in stature and gained acceptance all over the world. Yet, it is a paradox that the term '*Management*' continues to be the most misunderstood and misused. Certain questions like whether management is a science or art or profession are yet to be answered in a satisfactory way.

### **Management as Science**

To gain a correct perspective as to what management is, let us examine the exact nature of management – whether it is a science or an art? An understanding, therefore, of the exact nature of science as well as art may help in understanding the discipline in a better. Any branch of knowledge to be considered a science, (like the ones we have – physics, chemistry, engineering, etc.) should fulfill the following conditions:

- ▶ the existence of a systematic body of knowledge encompassing a wide array of principles;
- ▶ principles have to be evolved on the basis of constant enquiry and examination;
- ▶ principles must explain a phenomenon by establishing cause-effect relationship;
- ▶ the principles should be amenable for verification in order to ensure accuracy and universal applicability.

Looked at from this angle, management as a discipline fulfils the above criterion. Over the years, thanks to the contributions of many thinkers and practitioners, management has emerged as a systematic body of knowledge with its own principles and concepts. Principles help any practicing manager to achieve the desired goals. However, while applying the principles, one should not lose sight of the variables in the situation, since situations differ from one to another. Thus, the importance of personal judgment cannot be undermined in the application of principles. Further, management is a dynamic subject in that, it has drawn heavily from economics, psychology, sociology, engineering and mathematics, to mention a few. It is multi-disciplinary in nature, but a word of caution. Though management considering its subject matter and the practical

utility may be considered as 'science', for reason discussed below, it cannot be viewed as an '*exact science*'. In other words, it is a science, but an '*inexact science*' because:

- ▶ *Firstly*, management by definition involves getting the things done through people. Compared to the other inputs, '*people*', who constitute the human resource of any organization are unique in respect of their aspirations, attitudes, perceptions and the like. Dissimilarities in the behavior pattern are so obvious that standard research may not be obtained in otherwise similar conditions.
- ▶ *Secondly*, the behavior of the human beings cannot be accurately predicted. Hence, readymade and standard solutions cannot be prescribed.
- ▶ *Thirdly*, management is more concerned with future which is complex and unpredictable. As the saying goes, 'many a slip between the cup and the lip', changes in the environment may affect the plans and render even the most well drawn plans ineffective.
- ▶ *Lastly*, since a business organization exists in an environment, it has a two way interaction with the environment. The organization influences the environment by its several decisions and in turn is influenced by the various elements of the environment. Important among these are technological, economic, socio-cultural and political factors. The whole thing is so complex that however effective the plans are, one is prone to be taken over by the unexpected changes in the environment.

Unlike the pure or exact sciences where the results are accurate in the case of management, the various factors discussed above may force even the excellent plans and the strategies go haywire. Too many complexities and uncertainties render management an '*inexact science*'

### **Management as an Art**

Art refers to the 'know-how' – the ways of doing things to accomplish a desired result. The focus is on the skill with which the activities are performed. As the saying goes '*practice makes a man perfect*', constant practice of the theoretical concepts (knowledge) contributes for the formation and sharpening of the skills. Therefore, what is required is the right blend of the theory and practice. In a way, the attributes of science



and art are the two sides of a coin. Medicine, engineering, accountancy and the like require skills on the part of the practitioners and can only be acquired through practice. Management is no exception. As a university gold medalist in surgery may not necessarily turn out to be a good surgeon, similarly a management graduate from the best of the institutes may not necessarily be very effective in practice. In both the cases, the application of the knowledge acquired through formal education, requires ingenuity and creativity on the part of the practitioner. Correct understanding of the variables of the situation calls for pragmatism and resourcefulness.

Effective practice of any art requires a thorough understanding of the science underlying it. Thus science and art are not mutually exclusive, but are complementary. Executives who attempt to manage without the conceptual understanding of the management principles and techniques have to depend on luck and intuition. With a sound knowledge and the necessary skills to use such knowledge, they stand a better chance to succeed. Therefore, it may be concluded that *'management is both a science and an art'*.

### **Management as a Profession**

These are the days where we hear a lot about professional managers and their contribution to the economic development of the nation. Therefore, it is appropriate to know whether management is a profession. McFarland gives the following characteristics of a profession:

- ▶ existence of an organized and systematic body of knowledge,
- ▶ formalized methods of acquiring knowledge and skills,
- ▶ existence of an apex level body with professionalization as its goal,
- ▶ existence of an ethical code to regulate the behaviour of the members of the profession,
- ▶ charging of fees based on service, and
- ▶ concern for social responsibilities.

A closer examination of management as a profession reveals that unlike medicine or law, management has to go a long way to attain universally acceptable norms of behaviour. There is no uniform code of conduct that governs the behaviour of managers. The apex level body, the All India Management Association (AIMA) or NIPM [National Institute

of Personnel Management] provides only guidelines and does not have any controlling power over the erring members. Managers also differ widely in respect of their concern for the ethics and values of the society in which they function. Many a time, in their obsession with profit, the societal interests are either neglected or compromised. However, as in the case of other professions, it is implied that managers are expected to set an example in doing good to the society. While making decisions, they should be conscious of the impact of their decisions on the society. The larger interests of the society must be given top priority rather than short-term temptations. After all, given the enormous resources they have at their command, the expectation that managers should address themselves to the problems of society is not unnatural.

It must, however, be remembered that unlike professions like engineering, medicine, law, accountancy, etc., the entry to management profession is not restricted to individuals with a special degree. In other words, one need not necessarily possess M.B.A or any other management degree or diploma to practice management. To quote Peter Drucker, “no greater damage could be done to an economy or to any society than to attempt to professionalize management by licensing managers or by limiting access to management to people with a special academic degree”.

In spite of the growing number of management institutes and the large number of people trained in the management, it is an irony that we still hear the debate - “*whether managers are born or made*”. The successes achieved by a few visionaries and great entrepreneurs are often sighted in support of the argument. It is true that many founding fathers of the industry in India and elsewhere too did not study management in the formal way. The native wisdom coupled with their vision in understanding the market and organizing the enterprises helped them earn name and fame. Huge industrial empires were built with sheer business acumen and commonsense. The Marwaris and Parsees in the north and Chettiars, and Naidus in the south India, the Jews in the west and the Samurai community in Japan, for instance, offer a classic example of such success stories. The successes achieved by the pioneers in these cases amply demonstrate that success in business requires much more than academic degrees.

At the same time, it may be realized that the achievements of the pioneers of the industrial development need not shadow the importance

of management as a profession. In arguing for and against, we must not ignore the context of the business. There has been a sea change in the environment of the business. The modern business has become more complex due to the uncertainties arising mainly from:

- ▶ Ever increasing competition for the markets not only domestic but international as well;
- ▶ Rapid technological changes affecting all facets of human life;
- ▶ Increased sophistication and rapid obsolescence of technology;
- ▶ Expansion in the size of organizations and consequently the market, and
- ▶ The unexpected changes in the socio-cultural and political factors influencing the business.

All these variables which have a significant bearing on the functioning of a business point to the need for formal training and acquisition of skills by pursuing management education. More so, at a time when people are talking about “borderless management” in the context of globalization of business.

### **Professionalisation of Management in India**

In the last few years, management as a profession has gained a firm footing in India. The awareness about the contributions of professional managers has been increasing. Consequently, there has been a manifold increase in the number of institutes offering MBA and related diploma courses resulting in a phenomenal increase in the number of students seeking admission into the management programs. Interestingly, the awareness of the society of the importance of professional education for the management of various sectors also is growing. Foreexample, the specialized programs to cater to the specific needs of the sectors like Hotel and Tourism Industry, Transport, Health care, Foreign trade, etc.

***The following factors are, among others, seem to be responsible for the growing demand for professional managers:***

- ▶ The liberalization of the Indian economy opened up new vistas for the Indian organizations. As a consequence, competition has increased in all the sectors of the economy, forcing the firms to be efficient;

- ▶ Private industrial houses which were indifferent before, have fully realized the need for professional managers. While the promoters in many cases still reserve the policy formulation for themselves, the day-to-day managerial activities are entrusted to the professional managers. The Murugappa Group's infusion of professional managers, rather than family-based experts, into the top posts is case in point.
- ▶ Public sector undertakings are also, of late, forced to perform, if the number of Memorandum of Understandings (MOUs) signed by the managements of PSUs and the concerned ministries of the Government is any indication. As a result, qualified managers are sought after by PSUs than ever before.
- ▶ Apart from the manufacturing concerns, public utilities like transport, telecommunications, and a host of service organizations like banking, insurance, tourism and healthcare are recruiting professional managers in a big way than ever before. The campus visits by scheduled banks [in both private and public sector] stand as a testimony to what is in offing to the demand for professional managers.

### **Functions of Management**

Among the various approaches to the study of management, the process approach has gained wider acceptance. It is because this approach lays emphasis on what a manager does. A manager no matter his level in the organization performs several functions. There is no consensus among the management thinkers on the classification of management functions. The number of functions as well as the terminology used to describe them is not alike. Henry Fayol identifies five functions, viz., planning, organizing, commanding, co-coordinating and controlling. Newman and Summer recognize only four functions, namely – planning, organizing, staffing, and directing. Koontz and O'Donnel classify the functions into planning, organizing, staffing, directing, and controlling. For the purpose of our study, we shall confine the discussion to the following five functions of management – planning, organizing, staffing, directing and controlling.

## **Planning**

Planning in simple is looking ahead. It is preparing for the future. It involves outlining a future course of action. Planning makes the things to happen. Therefore, it is needless to say that in the absence of planning, things are left to chance. Planning is unique in that it precedes all the other managerial functions. It involves deciding the objectives and formulating the policies and procedures to achieve them. Effective planning provides answers to questions like – what to do? How to do? Who is to do? and when to do?

Planning is a function performed by managers at all levels. Though every manager plans, the plans developed by different managers may vary in respect of scope and importance. For example, plans made by top managers have a wider scope with a focus on the organization as a whole and normally cover a longer period. On the other hand, plans developed by middle and lower level managers relate to the divisions or departments and usually cover a short period. Systematic planning helps in facing the uncertainties of future with less embarrassment. It helps in making things happen in the expected way.

## **Organizing**

Organizations achieve objectives by using physical and human resources. When people work in groups, everyone in the group should know what he/she is expected to achieve and with what resources. In other words, organizing involves establishing authority - responsibility relationships among people working in groups and creating a structural framework. Thus, the manager's task in organizing aims at creating a structure that facilitates the achievement of goals. Organizing therefore involves:

- ▶ determination of activities required to achieve goals;
- ▶ grouping of these activities into departments;
- ▶ assignment of such groups of activities to a manager;
- ▶ delegation of authority to carry them out; and
- ▶ provision for coordination horizontally and vertically in the organization.

The managerial function of organizing involves designing the structure and establishing functional and operational relationships. The resulting structure varies with the task. A large organization with huge market needs a different structure compared to a small organization. Similarly, structure of an organization operating in a stable environment may be different from the one operating in a dynamic environment.

### **Staffing**

Organising process results in the creation of a structure with various positions. Staffing involves manning the various positions of the organisation. It includes manpower planning, recruitment and selection of the right people, training and developing them, deciding financial compensation, appraising their performance periodically. There is a debate whether staffing function is to be performed by all managers in the organisation or handled by human resources department alone. However, some processes of staffing are performed by personnel department only. For example recruitment and selection, training, fixation of salary, etc. Performance appraisal, on the other hand, may be done by all managers.

### **Directing**

Once plans are made and the organisation is created, the focus shifts to the achievement of objectives. This function is called by various names: directing, leading, motivating, actuating and so on. It basically involves directing or leading the activities of the people. The manager directs the activities of his subordinates by explaining what they have to do and by helping them perform it to the best of their ability. In leading the people, the manager performs the following three distinct tasks:

Communication : the process of information flow from one person to another and across the organization;

Leadership : the process by which a manager guides and Influences the work of his subordinates; and

Motivation : the act of stimulating the people so that they give their best to the organisation.

Leading is a function predominantly interpersonal in nature. In the organizational context many problems arise because of the failure of managers to understand the people, their aspirations, attitudes, and behaviour as individuals and in groups. If the manager fails in leading the people towards better performance, any amount of planning and organizing, however effective they are, may not help the organisation.

### **Controlling**

Planning and controlling – the two functions are closely interrelated in that while plans specify the objectives to be achieved, control as a managerial function facilitates to know whether the actual performance is in conformity with the planned one. So that, in the event of deviations, appropriate corrective measures could be taken. In the absence of adequate control mechanism, unexpected changes in the environment may push the organisation off the track. Thus, controlling implies measuring and correcting the activities to ensure that events conform to plans. That is why planning and controlling are often described as the ‘Siamese’ twins of management. It involves four main elements:

- ▶ Establishing standards of performance;
- ▶ Measuring the actual performance and comparing it against the standard performance;
- ▶ Detecting deviations, if any, in order to make corrections before it is too late; and
- ▶ Taking appropriate corrective measures.

### **Review Questions**

1. “Management is oldest of the arts and youngest of the sciences”. Discuss
2. Is management an exact science? Substantiate your answer with examples.
3. Examine the status of management as a profession in India?
4. Briefly describe the functions of management?

5. Identify 5 organizations / industry groups which moved from family based to professional management and describe the process drawing from all accessible sources – public domain [web pages, for instance], your interviews with personnel from such organizations,....]

\*\*\*



---

## Lesson – 2 : Levels In Management

---

### Objectives

*After reading this lesson, you should be able to:*

- Describe The Levels In Management;
- Understand The Skills Required At Each Level Of Management;  
And
- Appreciate The Roles Played By Managers.

### Lesson outline

- Levels Of Management
  - Top Level Of Management
  - Middle Management
  - Front Line Management
- Managerial Skills
  - Technical Skills
  - Human Skills
  - Conceptual Skills
- Managerial Roles
- Review Questions

In any organization all those who are responsible for the work of others are known as managers. Though their primary task remains the same – getting the things done by other people, wide variances exist with regard to the authority and responsibility of managers. These differences are largely due to the differences in the levels of management. Based on the scope of authority and responsibility, management job requires many skills and talents. As a matter of custom and convenience, we normally visualize a company's management as a pyramid as shown in figure 2.1.

## Levels of Management

The three levels of management that are commonly found in any organisation are lower or front-line, middle and top management.

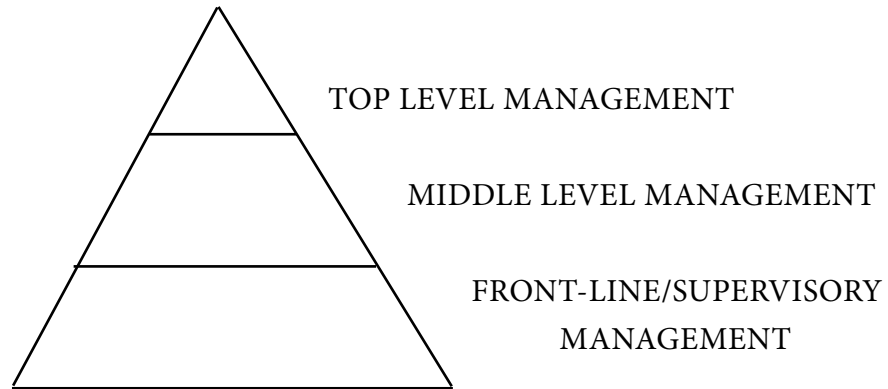

**Figure 2.1: Levels of Management**

### Front-Line or Supervisory Management

This is the lowest level in the hierarchy of management. Usually the jobs at this level are the entry level positions into management profession. Managers at this level direct the operating employees (workers). They are close to the action for their job involves supervising the activities of operatives. Front-Line managers in the production department are called foreman, supervisor, superintendent, inspector and so on. For instance, in a manufacturing concern, in marketing, finance and others departments, they are called management trainees or junior executives. Similarly, in a government office, the term superintendent or section officer is preferred.

### Middle level Management

Middle management level includes in many organizations more than on level. Managers who work at levels between the lower and top levels constitute the middle management. Departmental heads, Regional managers, Zonal managers and so on fall in this category. They report to top managers. Their principal responsibilities are to direct the activities of lower level managers who implement the organization's policies.

## Top level Management

Top management constitutes the highest level in the management hierarchy. This is the policy making level in any organization. This level consists of a small group of executives. Board of Directors, Chairman, Managing Director and the top functional heads such as COO, CIO, and such other C-suite managers, and divisional managers comprise this level. Top managers are responsible for the overall management of the organization. They decide the enterprise objectives, policies and strategies to be pursued to achieve the objectives. They provide direction to the organization by guiding its interactions with the environment.

## Managerial Skills

Management job is different from other jobs. It requires elements of stewardship and commitment to the purpose. It involves the obligation to make prudent use of human and material resources. It requires sound judgment to handle complex situations. Further, the nature of the job becomes increasingly complex at each higher level because of the increase in the scope of authority and responsibility. Therefore, each higher level requires increased knowledge, broader perspective and greater skills.

For the purpose of analysis, skills required of a manager are classified under three heads – *technical*, *human* (employee relations skill) and *conceptual* skills as shown in Figure 2.2. The exhibit helps in understanding the levels of management responsibility, the principal skill requirements, and the extent to which each kind of skill is required at each level.

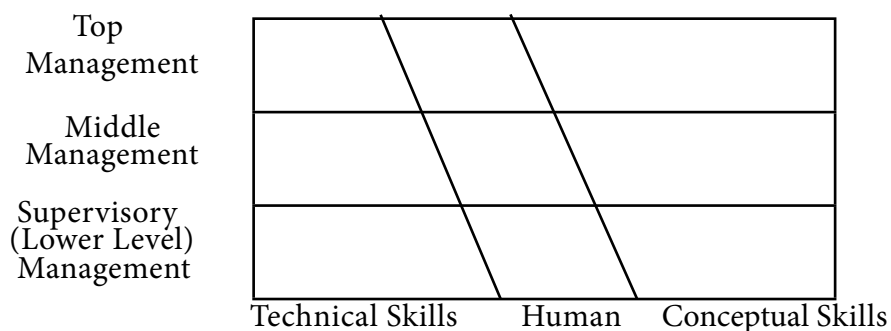

**Figure 2.2: Management Levels and Skills**

## **Technical Skills**

Technical skills refer to the ability to use the tools, equipment, procedures, techniques and knowledge of a specialized field. It is primarily concerned with the ways of doing the things. It implies proficiency in a specific field of activity. Technical skills are most important for the lower level managers, because by nature their job involves supervision of the workers. Effective supervision and coordination of the work of the subordinates, therefore, depends on the technical skill possessed by the lower level manager. Any supervisor without a sound knowledge of the job cannot make an effective supervisor. Such supervisors are not respected by the subordinates at the shop floor. The relative importance of the technical skills as compared to the other skills diminishes as one move up to higher levels of management.

## **Human Skills**

Human skills are primarily concerned with “*persons*” in contrast to “*things*”. When a manager is highly skilled in employee relations, he is aware of their attitudes, assumptions, and beliefs and recognizes their limitations as well as their usefulness. He accepts as an important fact of life, the existence of viewpoints and feelings, different from his own. Thus, human skills refer to the ability of the manager to work effectively as a group member and to build cooperative effort in the team he leads. It is the ability to work with, understand and motivate people. He understands why people behave as they do and is able to make his own behaviour understandable to them. He can foresee their reactions to possible courses of action. His skill in working with others is natural and continuous. He does not apply it in random or in inconsistent fashion. It is a natural ingredient of his every action. The flair for understanding, empathizing and working with people are central to the human skills.

## **Conceptual Skills**

Conceptual skills also called design and problem-solving skills involve the ability to:

- see the organization and the various components of it as a whole;
- understand how its various parts and functions are related in a

- network fashion; and
- ▶ to foresee how changes in any one of these may affect the others.

Conceptual skills extend to visualizing the relation of the organization to industry, to the community and to the political, economic and social forces of the nation as a whole and even to forces which operate beyond the national boundaries. It is the creative force within the organization. A high degree of conceptual skill helps in analyzing the environment and in identifying the opportunities and threats. Managements of companies like ITC, Larsen & Toubro, Asian Paints, Bajaj Auto, Bharthi Telecom in the private sector and National Dairy Development Board, Bharat Heavy Electricals (BHEL) in the public sector, to mention a few, have amply demonstrated this skill in gaining a competitive edge over their competitors.

As you have understood by now – the three types of skills discussed so far are not mutually exclusive. In other words, management job always requires all the three skills, but in different proportions depending upon the level of management. There is a gradual shift in the emphasis from the bottom to the top of the pyramid. Technical skills and human skill are always in great demand at the lower level of management for it is there the productive processes and operations are carried out. It is there where you find most of the people. It is there where the action takes place. In contrast, the need for conceptual skill is greatest at the top level of management. Obviously, top managers are not often involved in the direct application of specific methods, procedures and techniques, compared to those at the lower echelons of management.

As evident from the foregoing discussion, at the entry level of the management job, that is, at the supervisory level, besides technical skills, a manager has to possess human skills and the problem-solving skills (conceptual). To climb up the organizational ladder, one must not only be good at the skills required for the present job, but also learn and acquaint with the skills required at the next level. As result, in the event of promotion to the next higher levels, he/she would feel at home and discharge the responsibilities with ease.

Based on the differences in the type of skills required, organizations assess the training needs of the managers. Accordingly, appropriate training,

development methods and programs are designed to equip them with the skills required at the respective levels. Although, each of these skills is needed in some degree at every level of management, there are successful executives who have no great amount of technical skills. But they are able to compensate the lack of that skill through superior creative ability and skill in identifying the talent and empowering the people through effective human resources development practices and good leadership.

## Managerial Roles

Hennerly Mintzberg, a contemporary management thinker has done lot of research on the various roles performed by a manager. A role, according to him, “*Is an organized set of behaviors belonging to an identifiable office or position.*” Just as characters in a play have specific roles, managers also play different roles. Through his studies, Mintzberg identified ten roles that managers play at various times to varying degrees. He classified them under three broad categories; interpersonal roles, informational roles, and decisional roles. Figure 2.3 summaries the ten roles by category with examples of each.

MANAGEMENT ROLES AS IDENTIFIED BY MINTZBERG

ROLE	Description	Identifiable activities from the study of Chief Executives
<b>Interpersonal</b>		
<b>Figure head</b>	Symbolic head; obligated to perform routine duties of a legal or social nature.	Ceremony, status requests, solicitations.
<b>Leader</b>	Responsible for the motivation and activation of subordinates; responsible for staffing, training and associative duties.	Virtually all managerial activities involving subordinates.

Liaison	Nurtures and maintains network of outside contacts. The liaison role involves interface activities with environment.	Acknowledgement of mail, authorizing communication with external world.
<b>Informational</b>		
MONITOR	Seeks and receives wide variety of special information from different sources. Thorough understanding of organization and environment; emerges as nerve centre of internal and external information of the organization.	All activities concerned primarily with receiving and processing information.
Disseminator	Transmits information received from both within and outside the organization to members of the organization; some information factual, some involving interpretation and integration of diverse value positions of organizational influencers.	Forwarding mail for informational purposes, verbal contacts involving information flow to subordinates(eg; review sessions, instant communication flows)
Spokesman	transmits information to stake holders about external environment and organization's plans, policies, actions, results, etc;	board meetings; handling contacts involving transmission of information to outsiders.

Decisional		
<b>Entrepreneur</b>	Searches the environment for opportunities and initiates action to bring about changes; supervises design of strategy and review sessions involving initiation or improvement of projects.	
<b>Disturbance handler</b>	Responsible for corrective action when organization faces unexpected disturbances and turbulence.	Strategy and review sessions involving disturbances and crises.
<b>Resource allocator</b>	Responsible for the allocation of organizational resources of all kinds; making or approval of all significant organizational decisions.	Scheduling requests for authorization; and activities involving budgeting and the programming of subordinates work.
<b>Negotiator</b>	Responsible for representing the organizations at major negotiations	Negotiation.

As Mintzberg points out, these roles are not independent of one another. Instead, they are interdependent. The interpersonal roles arise out of the manager's authority and status in the organization and involve interactions with people. These interpersonal roles make the manager a focal point of information, enabling and compelling the manager to assume and play the informational roles as an information processing centre. By playing interpersonal and informational roles, the manager is able to play the decisional roles; allocating resources, resolving conflict,



seeking out opportunities for the organization, and negotiation on behalf of the organization. Taken together the ten roles comprise and define the work of the manager, whatever the organizations size and nature of the business.

### **Review Questions**

1. Explain the different levels in management and how the scope of authority and responsibility varies from one level to the other.
2. What are the skills required by a manager as he moves up the hierarchy? What methods do you suggest to equip the managers those skills.
3. Explain the importance of conceptual skills for long term survival of an organisation. How do good conceptual skills a firm gain competitive advantage? Give appropriate examples
4. Examine the different roles played by a manager of a typical business organisation.

\*\*\*



---

## Lesson - 3 : Social Responsibilities Of Business

---

### Objectives

*After studying this lesson, you should be able to:*

- ▶ Understand The Concept Of Social Responsibilities Of Business;
- ▶ Examine Clearly The Interest Of The Various Stakeholders In The Business; And
- ▶ Familiarize With The Arguments For And Against The Social Responsibilities Of Business.

### Lesson Outline

- ▶ The Concept
- ▶ Responsibilities To Various Groups
  - ▶ Towards The Customer
  - ▶ Towards The Employee
  - ▶ Towards Shareholders
  - ▶ Towards Creditors And Suppliers
  - ▶ Towards Governments
  - ▶ Towards Society At Large
- ▶ The Differing Perspectives
- ▶ Review Questions

The relationship between an organization and its environment has been examined in the previous lesson. An organization is understood as importing various kinds of inputs such as human and capital resources which are transformed into outputs such as products or services. Thus a business enterprise is part of the larger system, for it imports the inputs from the society and exports the outputs to the society. As a result, an inextricable link between the organization and the society may be seen. Peter F Drucker stated long ago that the moral and economic justification of a firm to exist lies in its making profit.

In this connection, it may be understood that in the olden days, the mission of the business was purely economic in nature. But as years passed, the role of business organization in the society has undergone a thorough change. Modern societies are increasingly looking up to the business concerns for the redressal of many of the social problems. Concern of the managers towards the society is now considered as one of the important parameters while giving the awards for best corporate performance/business of year award, etc., instituted by agencies like FICCI, FII, Business India and so on. As the expectations of the society on business are changing, there is urgent need for managers to understand clearly the concept of 'social responsibilities of business' so as to address themselves to the various issues involved.

### **Social responsibility-Meaning and Scope**

According to Keith Davis' social responsibilities of business refers to "the businessman's decisions and actions taken to reasons at least partially beyond the firms direct economic or technical interest". To quote Andrews, " By social responsibility, we mean intelligent and objective concern for the welfare of society that restrains individual and corporate behavior from ultimately destructive activities, no matter how immediately profitable, and leads in the direction of positive contribution to human betterment variously as the latter may be defined".

H.R. Bowen's observation on social responsibility is clearer and point to the specifics of the concept. He suggests that business managers are bound to "pursue those policies, to make those decisions, or to follow those lines of action which are desirable in terms of the objectives and values of our society". Thus as the above definitions indicate, the concern for the society on the part of managers imply a particular behavior which is in line with the societal interests. It suggests that refrain from actions detrimental to the interests of the society.

### **Responsibilities to Various Groups**

In a broad sense, business owes a lot to the various groups such as customers, employees, shareholders, government and the community at large in which it exists. These groups in the society are called 'interest groups' or 'stakeholders' in the business organization. Let us examine

how an organization responds in socially responsible ways to cater to the growing demands of all these interest groups.

### **Towards the Customers**

Production and supply of quality goods and services at an affordable price is the primary responsibility of business. Customer service should be the motto of the business. It involves offering a fair deal to the customer by indulging in ethical business practices. Therefore every manager in order to serve the customers in an effective way should restrain from:

- ▶ making misleading advertisements aimed at deceiving the consumer;
- ▶ giving wrong or false information about the ingredients, quality, origin, etc., of the product;
- ▶ entering into collusive agreements with other firms to exploit the customers;
- ▶ making false claims of being an authorized dealer/importer of certain goods; and
- ▶ giving misleading names to the products, etc.

### **Towards Employees**

- ▶ proper selection, training and promotion;
- ▶ recognition of the value of human resource;
- ▶ maintaining cordial relations with employees;
- ▶ recognition and encouragement of constructive unionism;
- ▶ fair wage in relation to the cost of living;
- ▶ better working conditions;
- ▶ initiating appropriate measures for the development of human resource; and
- ▶ increase in productivity and efficiency by recognition of merit, by providing opportunities for creative talent and incentives.

## **Towards Shareholders**

Shareholders are the real owners of the business. In view of the several practical limitations for them in overseeing the day-to-day operations of the business, an organization must strive to provide:

- ▶ Security to their funds;
- ▶ A fair rate of return on their investment;
- ▶ Correct information about the operations of the company; and
- ▶ Proper appreciation of the value of their investment in the company by identifying new opportunities that contributes for the growth of the business.

## **Towards Creditors/Suppliers**

Creditors or suppliers provide the necessary inputs to the business. Business has, therefore, certain responsibilities to them. Business can discharge its responsibilities towards this group by:

- ▶ Realizing the importance of maintaining good business relations with them;
- ▶ Meeting the payment obligations timely;
- ▶ Providing true and correct picture about the financial aspects of the company; and
- ▶ Helping them grow along with the growth of the company, etc.

## **Towards Government**

Government provides various facilities for the development of business. Infrastructural facilities like roads, telecommunication, transport, banking, insurance are some of the facilities created by the government without which no business, worth mentioning can conduct its affairs smoothly. Therefore, business also in turn owes to the government in the following ways.

- ▶ Business enterprises should act like law-abiding citizens;
- ▶ Taxes and other duties should be paid timely and honestly;
- ▶ Compliance with the rules and regulations as stipulated by various laws of the land; and

- ▶ Supplementing the governments' efforts in the developmental activities, etc.

### **Towards Society at Large**

Any business organization can exist as long as it enjoys societal sanction. If it fails to safeguard the interests of the society, the pressure from various segments of the society mounts up. Such a situation eventually leads to the promulgation of various acts by the government. That is why, it is always desirable for the business to keep the government to bay. Some managements conduct their affairs in such a responsible way where governments intervention is not warranted. For instance, the origin of several laws governing the business organizations may be traced back to the failure of business organization in protecting the intensity of the various groups in the society. An organization can act in a socially responsible way by:

- ▶ Properly deciding the product policies in line with the national priorities;
- ▶ Preventing the creation of monopolies;
- ▶ Ensuring hygienic disposal of smoke and waste and other effluents;
- ▶ Providing to the community accurate information about its working; and
- ▶ Preserving the national resources of the nation by not indulging in reckless exploitation of the resources, etc.

### **The Differing Perspectives**

There are different views on the social responsibilities of business. The views may be broadly classified under two categories: those for and against the social responsibilities of business.

One view, strongly advocated by Nobel Laureate in economics, Milton Friedman, on proper role of business "to use its resources and energies in activities designed to increase its profits so long as it stays within the rules of the game and engages in open competition, without deception and fraud". According to Friedman, socially responsible business is concerned primarily with efficiency and providing its owners with the best possible

return on investment within the parameters established by law and ethical conduct. Solving social problems such as eliminating poverty, eradication of illiteracy is the task of government. If business directly deals with social problems, the costs of doing will be reflected in the prices of goods and services.

Other writers contend that profit should not be management's only concern. Organizations should sacrifice a little for the good of the society. In support of this view, Keith Davis states that business must be socially responsible because of "a iron law of responsibility" contending that in the long run those who do not use power in the manner that society considers responsible will tend to lose it"

As discussed above, there are divergent views on the issue. One's views on the correct role of business in society are influenced by one's values. There is no right or no wrong answers to the question. All the view points are presented in the form of arguments for and against social involvement of business.

### **Arguments for Social Involvement for Business**

1. Public needs have changed, leading to different expectations. Business, it is suggested, received its charter from society and consequently has to respond to the needs of society.
2. The creation of a better social environment benefits both society and business. Society gains through better neighborhoods and employment opportunities; business benefits from a better community which is the source of its labor and where it sells its products and services.
3. Social involvement discourages additional government regulation and intervention. The result is greater freedom and more flexibility in decision making for business.
4. Business as a great deal of power which, it is reasoned, should be accompanied by an equal amount of responsibility.
5. Modern society is an interdependent system and the internal activities of the enterprise have an impact on external environment.
6. Social involvement may be in interest of stockholders.
7. Problems can become profits. Items that may once have been considered waste (for example, empty soft drink cans) can be



profitably used again.

8. Social environment creates a favorable public image. Thus, a firm may attract customers, employees, investors.
9. Business should try to solve the problems which other institutions could not. After all, business has a history of coming up with novel ideas.
10. Business has the resources. Specifically, business should use its talented managers and specialists, as well as its capital resources, to solve some of society's problems.
11. It is better to prevent social problems through business involvement than to cure them. It may be more effective to help the hard-core unemployed than to cope with social.

### **Arguments against Social Involvement of Business**

1. The primary task of business is to maximize profit and to focus strictly on economic activities. Social involvement could reduce economic efficiency.
2. In the final analysis, society may have to pay for business's social involvement through high prices. Social involvement may create excessive costs to business and keep it from committing its resources to economic opportunities.
3. Business has enough power, and additional social involvement would further increase its power and influence.
4. Business people lack the social skills to deal with the problems of society. Their training and experience are with economic matters, and the acquired skills may not be pertinent for solving social problems.
5. There is a lack of accountability of business to society. Unless accountability can be established, business should not get involved.
6. There is not complete support for involvement by business in social actions. Consequently, disagreements among groups with different viewpoints will cause frictions.

In spite of the growing concern for the social problems, it has to be remembered that profit is essential for the survival of business organization. Profit is to a business what food, water and air are to an individual. As such, every organization has to strike a balance between making profits and discharging social responsibilities. Both are not mutually exclusive,

but are complementary.

According to Keith Davis, “Social Responsibilities refer to the businessman’s decisions and actions taken to reasons at least partially beyond the firm’s direct economic or technical interest”. To quote Andrews, “By social responsibility, we mean intelligent and objective concern for the welfare of society that restrains individual and corporate behaviour from ultimately destructive activities, no matter how immediately profitable, and leads in the direction of positive contribution to human betterment, variously as the latter may be defined”.

H.R.Bowen’s observation on social responsibility is more clear and point to the specifics of the concept. He suggests that business managers are bound to “pursue those policies, to make those decisions, or to follow those lines of action which are desirable in terms of the objectives and values of our society”. Thus, as the above definitions indicate, the concern for the society on the part of managers implies a particular behaviour which is in line with the societal interests. It suggests that they refrain from actions detrimental to the interests of the society.

### **Responsibilities to Various Groups**

In a broad sense, business owes a lot to the various groups such as customers, employees, shareholders, government and the community at large in which it exists. These groups in the society are called interest groups’ or ‘stakeholders’ in any modern business organisation. Let us examine how an organization responds in socially responsible ways to cater to the growing demands of all these interest groups.

#### **Towards the Customers**

Production and supply of quality goods and services at an affordable price is the primary responsibility of any business. Customer service should be the motto of the business. It involves offering a fair deal to the customer by indulging in ethical business practices. Therefore, every manager in order to serve the customers in an effective way should restrain from:

- ▶ making misleading advertisements aimed at deceiving the consumer;
- ▶ giving wrong or false information about the ingredients, quality,

- origin, etc. of the product;
- entering into collusive agreements with other firms to exploit the customers;
- making false claims of being an authorized dealer / importer of certain goods; and
- giving misleading names to the products, etc.

### **Towards Employees**

- proper selection, training and promotion;
- recognition of the value of human resource;
- maintaining cordial relations with employees;
- recognition and encouragement of constructive unionism;
- fair wage in relation to the cost of living;
- better working conditions;
- initiating appropriate measures for the development of human resource;
- increase in productivity and efficiency by recognition of merit; and
- providing opportunities and incentives for creative talent.

### **Towards Shareholders**

Shareholders are the real owners of a business. In view of the several practical limitations for them in overseeing the day-to-day operations of the business, an organisation must strive to provide:

- security to their funds;
- a fair rate of return on their investment;
- correct information about the operations of the company; and
- proper appreciation of the value of their investment by identifying new opportunities that contribute to the growth of business.

### **Towards Creditors / Suppliers**

Creditors or suppliers provide the necessary inputs to the business. Business has, therefore, certain responsibilities to them. The management can discharge its responsibilities towards this group by;

- realizing the importance of maintaining good business relations with them;
- meeting the payment obligations timely;
- providing true and correct picture about the financial aspects of the company; and
- helping them grow along with the growth of the company, etc.

### **Towards Government**

Government provides various facilities for the development of business. Infrastructural facilities like roads, telecommunication, transport, banking, insurance are some of the facilities created by the government without which no business, worth mentioning can conduct its affairs smoothly. Therefore, business also in turn owes to the government in the following ways;

- Business enterprises should act like law-abiding citizens;
- Taxes and other duties should be paid timely and honestly;
- Compliance with the rules and regulations as stipulated by various laws of the land; and
- Supplementing the governments efforts in the developmental activities, etc.

### **Towards Society at Large**

Any business organisation can exist as long as it enjoys societal sanction. If it fails to safeguard the interests of the society, the pressure from various segments of the society mounts up. Such a situation eventually provokes the government to invoke the regulatory mechanism. That is why, it is always desirable for the business to keep the government at bay. Some managements conduct their affairs in such a responsible way where government's intervention is not warranted. For instance, the origin of several laws governing the business organizations may be traced back to the failure of business organizations in protecting the interests of the various groups in the society. An organization can act in a socially responsible way by:

- properly deciding the product policies in line with the national priorities;

- preventing the creation of monopolies;
- ensuring hygienic disposal of smoke and waste and other effluents;
- providing accurate information about its working; and
- preserving the national resources of the nation by not indulging in reckless exploitation of the resources, etc.

### **Review Questions**

1. Explain the roles and responsibilities of major stakeholder of a business organisation.
2. What do you mean by social responsibility of business? Do you subscribe to the view that business has responsibilities other than making profit? Substantiate your answer drawing from real examples.
3. Much of the talk about social responsibility is more of rhetoric in nature. Examine the statement and present your views. You are welcome to interact with management personnel and present your viewpoints.
4. Present your views for and against the social responsibility of business.

\*\*\*



---

## Lesson – 4 : Manager And Environment

---

### Objectives

*After reading this lesson, you should be able to:*

- Understand The Importance Of Environment In Business;
- Explain The Dynamics Of Environment ;And
- Explain The Various Forces In The Environment That Affect Business.

### Lesson Outline

- Manager And Environment
- Direction Action Environment
- Indirect Environment
- Review Questions

Like human beings, organizations are the products of environment. As explained in Lesson – 1, all organizations whether engaged in business or non-business draw the inputs from the environment, convert the inputs into outputs and send them back to the environment. Thus, every organization has a two-way interaction with the environment.

A business organization is an open system which is influenced by the environment and in turn influences the environment. The environment of the business consists of two components – internal as well as external environment. The former refers to the various systems inside the organization such as, technology, structure, processes and people. As all these aspects constitute the subject matter of this course and are discussed in various lessons, the internal environment, therefore, does not merit a detailed analysis. As such, this lesson focuses on the important variables of the external environment which have a bearing on the successful functioning and survival of the business.

## **Importance of the Environment**

The need to consider the forces external to the organization was first incorporated into management thought during the late 1950s. It was one of the major contributions of the systems approach to management which emphasizes and stresses the need for managers to view their organization as an entity of interrelated parts intertwined with the outside world. In an ever changing business environment as of today, changes in the outside world have made the need to consider the environment more important than ever. As Alvar Elbing states, “the external environment of an organization is a subject of increasing challenge for today’s managers”. Even if changes are not so significant, management would still have to consider the environment because, as an open system, an organization is dependent on the outside world for supplies, energy, workers and customers. As all these effect the organization’s very survival, management must be able not only to identify the factors in its environment but also to cope with them.

In this respect, organizations are similar to biological organisms. According to Charles Darwin’s theory of evolution, the species that have survived have done so because they were able to evolve and adapt to changes in their environment. Organizations, too, must adapt to changes in their environment in order to survive and be effective.

## **Direct Action versus Indirect Environment**

The external environment affecting the organisation may be divided into two major categories – *Direct action and Indirect action* environment. Direct action environment consists of those factors that directly affect and are affected by the organization’s operations. These factors include suppliers, labor unions, and the various laws of the land, customers and competitors. The indirect action environment, on the other hand, consists of those factors that may not have an immediate direct effect on operations but nevertheless influence the activities of the firm. These include such factors as technology, socio-cultural and political factors, general economic conditions and so on. Let us now understand the impact of all these factors in detail.



## **Direct Action Environment**

### **Suppliers**

As already understood, an organization is a vehicle for transforming inputs into outputs. The important inputs are materials, equipment, energy, capital and labour. The relationship between the organization and the suppliers of these inputs presents the forces in the environment that directly influence the operations of a firm. If an organization is unable to obtain these essential inputs of right quality, quantity and at the right price, it cannot possibly achieve the objectives.

### **Laws**

Virtually every aspect of the business is influenced by the laws of the land. The form of organization, the management and the way how a firm conducts itself in the society are very much influenced by the various provisions of the laws. For instance, The Companies Act, Factories Act, Workmen's Compensation Act, Industrial Disputes Act, Provident Fund Act, just to name a few, affect the functioning of the business. As a responsible corporate citizen, an enterprise has to comply itself with the provisions of these acts.

### **Customers**

The justification for the existence of a firm lies in the satisfaction of customer needs. In this context, it is appropriate to remember Peter F. Drucker's observation on the purpose of business. According to him, the purpose of any business is to create a customer. There is no exaggeration that it is customers in the market place who dictate the fortunes of any business. Needless to say that those organisations which neglect the customer expectations and aspirations would find the long-term survival very difficult. Customers' tastes and preferences are not static, but keep on changing. Mention may be made of some of the changes in the recent past: the cell phone, the preference for quartz watches, audio-video gadgets, various sophisticated domestic appliances, cotton garments, fast foods and so on. Organizations which are adept in identifying the changes in the customers' attitudes and preferences or which can comfortably respond to the changes would survive and those which fail to take cognizance of changes would ultimately fall on the way side.

## **Competitors**

Many a policy of the organization are influenced by the competitors. In a competitive environment, the market place is characterized by moves and countermoves. The post-liberalization Indian markets for many products offer an excellent example as to how competition influences the organizations. In the last few years, in almost all the sectors of the Indian economy, competition has tremendously increased. As a result, many firms are forced to wake up from their slumber. They are forced to unlearn many of the practices and attitudes of the pre-liberalization/protection era. Company after company is now redefining its business, rediscovering the markets, talking in feverish pitch about customer service, human resource development and concern for the society.

## **Indirect Environment**

Indirect environment of business is usually more complex and uncertain than the direct. Management is often compelled to make assumptions about the impact of the various factors like technology, general economic conditions, socio-cultural and political factors. Let us, therefore, examine the impact of these factors on the business.

## **Technology**

Technology, in the organizational context, influences the ways of doing things. It influences various processes. Technological changes affect the efficiency with which products are manufactured and sold, when a product will become obsolete, how information can be gathered and processed, and what customers expect from the organization's products and so on. Important technological developments that have profoundly affected the organizations and society in the last two decades are the computer, cell phone technology, laser, xerography, integrated circuits, semiconductors, television, satellite communication, nuclear power, synthetic fuels and foods, etc. All these innovations have thoroughly changed the face of the society. Therefore, today's organizations need to keep abreast of technological changes that affect their operations and products so as to remain competitive. Failure of the management to clearly gauge the technological changes would cost the business dearly. It endangers the very survival of the organization.

The pace at which technological changes occur varies from industry to industry. In some industries where technology is stabilized, the changes are less frequent and less turbulent. On the other hand in some industries like information technology, telecommunication systems, polymers, etc. changes are frequent. Depending upon the nature of business and the type of technology used, every organization has to assess the technological environment from time to time.

### **Economic Conditions**

Managers must also assess how changes in general economic conditions will affect the operations. The fluctuations in economic activities of a nation as measured by the various parameters like the gross domestic product (GDP), price level, employment, aggregate demand and supply of consumer and industrial goods, etc. have far reaching impact on the prosperity of the business. These factors affect the cost of the inputs and the ability of customers to buy the goods and services. Organizations' must be able to tackle effectively the inflationary and recessionary trends in the economy. When the economy is in an upbeat mood, firms normally benefit enormously and commit the resources for further growth with a hope of continuity of favorable economic conditions. Problems arise when the economy turns downswing. It is at that stage, firms have to adjust themselves to the down turn in economic conditions. Efficiency in operations, elimination of wastage, product planning, etc. hold the key for the survival of firms in such an adverse economic climate. As business organisations, in terms of size and impact, have grown into mega institutions, their failure will have disastrous effects on the society. By virtue of their size, they also influence significantly the economic stability of the nation. Further, it is important to note that a given change in economic environment may have a positive effect on some organizations and a negative effect on others. Therefore, a manager must be able to clearly assess the impact of changes in economic conditions on the industry in general and his firm in particular.

### **Socio-Cultural Factors**

Organisations are affected by the culture of the particular society in many ways. Firms which have their operations in more than one country have to adapt to the respective cultures in an effective way. Otherwise, they

find it difficult to gain the acceptance of the society. Sound understanding of the cultural variables is all the more important for firms in a country like India where there are several diversities in cultures of various regions within the country.

Culture is a wider concept which includes value systems, beliefs, likes and dislikes, attitudes and perceptions. If the products or services of a firm are not in line with the culture of the place, they may not be accepted by the society. For instance, in India 'Miss' brand cigarette targeted at the women was a failure because it is against the cultural ethos of the society. Likewise at the international level, many brands have failed because they are out of tune with the respective cultures. At the same time, it may be remembered that certain products and services also affect the culture of a place. The satellite television and the cell phone that made deep inroads into the Indian culture, and how certain values particularly in the Indian youth are changing makes a good example.

As such, an organization cannot insulate itself from the socio-cultural factors specific to a community. For example, paying bribes to obtain contracts or political favors, promotion on the basis of favoritism instead of competence, and spreading unfavorable rumors about a competitor are considered unethical and immoral business practices in many countries. In some countries such practices are seen as normal and accepted business practices because of differing socio-cultural factors. In this regard, General Electric's former chairman Reginald Jones observation is worth mentioning. He states that "organizations must be able to anticipate the changing expectations of society; and serve them more effectively than competing firms. This means that the organization itself must change, consciously evolving into an institution adapted to the new environment".

### **Political Environment**

The performance, growth and survival of business in general, to a larger extent, depend on the attitude of the government towards business. Since government is fully empowered to monitor and control the various institutions of the society, the policies pursued by the government affects the business in a significant way. The continuity of policies is very much essential. That depends on the stability of the government of the

particular nation. For instance, the attitude of the government in India towards foreign companies has undergone dramatic change in the last two decades. In the late seventies during the Janata Party rule at the centre, Coca-Cola, IBM and a few other multinationals were forced to leave the country. There were several other restrictions on the equity holding of foreign partners. The whole thing has changed, in the last few years so much so that multinationals are not only welcome but are also offered many facilities.

The cooperation that exists between business and government in Japan has in fact helped the Japanese Companies to conquer the world markets in the last few decades. In Japan, Ministry of International Trade and Industry (MITI) extends all out support to the organizations to emerge internationally competitive. In India too, of late, we see a lot of change in the attitude of the government both at central and state level towards the business. Various state governments are weighing with each other with attractive packages to woo the foreign investment in many core sector industries.

The various factors discussed so far highlight the impact of the environment on the business. If companies like Dr, Reddy Labs, Tata Motors, Larsen & Toubro, Reliance, ITC, etc. are able to go global, it is precisely because of their ability to assess the changing environment effectively and to adapt to the changes with considerable ease. As a result, we see a few Indian companies reaching the status of being called Indian multinationals.

### **Review Questions**

1. Explain the influence of various forces of the environment on business.
2. Describe the major factors in the environment of business and how they affect the survival of an organisation.
3. Present the case of atleast two Indian Companies and explain how they responded to changes in the environment.

\*\*\*



---

## Lesson - 5 : Planning

---

### Objectives

*After reading this lesson, you should be able to:*

- ▶ Understand The Principles And Purpose Of Planning;
- ▶ Explain The Steps In Planning;
- ▶ Describe The Strategic/Long Range Planning; And
- ▶ Distinguish Operational Planning From Strategic Planning.

### Lesson Outline

- ▶ Objectives Of Planning
- ▶ Principles Of Planning
- ▶ Planning Process
- ▶ Characteristics Of Sound Plan
- ▶ Long Range And Short Range Planning
- ▶ Types Of Plans
- ▶ Review Questions

Planning is an important managerial function in that there is no choice between planning and no planning. The choice is only in regard to the method and techniques used to plan. It is anybody's knowledge that we plan many things in our day to day lives. We plan to go on a holiday trip, plan our careers, and plan our investments and so on. Organizations are no exception. Lot of planning is done by managers at all levels. Planning is the basic process by which we use to select our goals and determine the means to achieve them. Lot of information has to be gathered and processed before a plan is formulated. In other words, a plan is like a jigsaw puzzle. All the pieces have to be put together properly, so that they make sense.

Planning is necessarily forward looking. It is looking into the future. It bridges the gap between where we are and where we want to go. It involves visualizing a future course of action and putting it in a logical way. Let us look at the following observations about planning.

- “Failure to plan is planning to fail”.
- “Planning is outlining a future course of action in order to achieve objectives”.
- “Planning is looking ahead”.
- “Planning is getting ready to do something tomorrow”.
- “Plan is a trap laid down to capture the future”.

### **Purpose of Planning**

It is no exaggeration that in the absence of planning events are left to chance. In such a case, you as a manager are depending on luck. You may, as a result, in all probability end up in frustration. Organizations often fail not because of lack of resources, but because of poor planning. Whatever the resources you have, in the absence of systematic planning, the resources may not help you in achieving the objectives.

The following factors further highlight the importance of planning;

#### **a. To achieve objectives**

While developing a plan, you have to ask yourself a few questions.

- Why am I making this plan?
- What am I trying to accomplish?
- What resources do I need to execute the plan?

Objectives are the ends sought to be achieved by the organizations. The above questions, if properly answered provide lot of clarity to the objectives. In other words, they force you to be clear about the objectives, the time frame required to achieve them and the resources required. It forces you to visualize the future in an organized manner. The saying that “*when a man doesn't know what harbour he is making for, no wind is the right wind*” is quite appropriate in the case of planning. Systematic planning, thus, starts with a clear statement of objectives. All the important inputs necessary to achieve the objectives are carefully thought of. The uncertainties of the future, if any, are also taken into consideration.



**b. Plans make the things happen**

Effective managers anticipate future and prepare themselves to meet the challenges of the future. They are rather pro-active. They influence the outcome of the events in a significant way. In any modern business, the interests of many people are involved. The shareholders, employees, creditors, consumers and the Government are the major interest groups in any organization. Further, the interests and expectations of all these groups are varied and at times are in conflict. That apart, they constantly change in a dynamic business environment. In the light of the uncertainties involved in the environment, your job, as a manager, is to foresee the future and predict the consequences of actions. In other words, you have to look down the road into future and prepare yourself to meet the uncertainties ahead. A well thought out plan solves many of the problems associated with the future.

**c. Plans help to cope with change**

Organizations are products of environment. The ability to deal with the environment has enabled many an organization to survive, despite other weaknesses. Alert managements continually tune in to the environmental forces. On the other hand, managements which fail to adapt would eventually fall on the way side. Therefore, in the managerial job, you have to constantly analyze the impending changes in the environment and assess their impact on your business. For instance, the liberalization policies pursued by the government have, of late, brought in too many changes. Markets are shifting due to increased competition. Pressure on the existing resources is increasing. Expectations of the employees as well as the consumers are changing. Product life cycles are becoming shorter due to rapid technological changes. All these changes exert a tremendous pressure on the management.

**d. Plans double up as tools to control the events**

Planning and control are often described as the '*Siamese*' twins of management. When you plan the events, you make them happen in a particular way. The specific objectives decided in advance themselves become the standards. Therefore, it goes without saying that plans provide mechanism to know whether the events are happening in the way expected.

Planning ensures the events to conform to plans. Thus, if you do not plan (no clear objectives), you do not know what to control. Control assumes significance in a dynamic environment as of today, where several forces push you away from reaching the goal. Appropriate control devices help you to check the course from time to time, so that you will be able to take the appropriate corrective measures.

## **Principles of Planning**

Systematic planning is essential for the success and survival of any organization. Organizations fail not because they don't plan, but because they don't plan in an effective way. An understanding of the following principles helps one to achieve effectiveness in planning, so that you can guard yourself against the possible mistakes that are often committed by managers.

### **i. Take Time to Plan**

As the plan is a decision regarding a future course of action, it specifies the sequence of events to be performed. It involves the commitment of organizational resources in a particular way. Therefore, if a plan is not conceived well, the resources would be put to wrong use. It becomes a wasteful exercise resulting in agony and frustration. To avoid such unpleasant outcomes, several probing questions have to be asked. Planning in haste with incorrect information, unsound assumptions and inadequate analysis of the environment has to be avoided by all means. Otherwise, you may save some time in quickly developing a plan, but in the event of things going wrong, you are hard pressed for time and resources to correct yourself. It not only lands you in trouble, but the organization as well.

### **ii. Planning can be top down and bottom up**

Normally in any organization major enterprise plans are developed by the top management. These plans are wider in scope and provide the direction to the whole organization. They spell out what the organization wants to achieve over the years. The overall plan thus formulated by the top management is split into departmental plans. Accordingly, plans for production, marketing, finance, personnel and so on, stem from the basic

plan of the organization. The other operational plans at various levels down the organization flow from the departmental plans. This approach is called top-down approach to planning.

In contrast, bottom-up approach involves information emanating from the lower levels – that is, top management collects information from lower levels. On the basis of such information, plans are formulated. The underlying assumption is that people at the operational level are closer to the action and they possess valuable information. In this approach, the initiative for planning comes from the lower levels in the organization. This approach makes use of the rich experience of the subordinates. It also helps to motivate the people and elicit commitment from them. However, the choice of the method depends on the size of the organization, the organizational culture, the preferred leadership style of the executive and the urgency of the plan.

### **iii. Involve and communicate with all those concerned**

Modern business organizations are so complex that various operations are highly interrelated. Such an interrelation of activities requires the involvement of all the people concerned with the achievement of goals. For instance, a plan to improve the quality of the products (Quality control plan) may require the cooperation of the people in the production. Such participation helps in instilling a sense of commitment among the people. They also in turn gain a sense of pride for having been a party in deciding the plan. Such an involvement makes possible the process of sharing information. If concerned people are not involved, there may be unnecessary gaps in the execution because of lack of understanding of the plans.

### **iv. Plans must be flexible and dynamic**

Your managerial career indeed would be a “bed of roses” if there are no unexpected changes in the environment. Day in and day out, you are confronted with too many changes forcing you into so many dilemmas or problems. Most of such problems are caused by unexpected events in the environment. If the plan is rigid with less scope for modifications as required by the changes in the environment, the organization would ultimately sink. In a static environment, of course, there may not be a

problem with a rigid plan. But in a dynamic environment, to meet the unexpected changes, adequate flexibility has to be built into the plan. Otherwise, the plan itself becomes a limiting factor.

v. **Evaluate and revise**

While building into the plans the required flexibility, you should not lose sight of the additional costs involved to buy such flexibility. You must also remember that flexibility in plans may not be possible always. For example, a plan for a petroleum refinery may not offer any flexibility because the machinery can hardly be used for any other purpose. Evaluation of the plan at regular intervals is necessary to make sure that it is contributing to the objectives. Like a pilot, who in the high skies checks the course to make sure that he is flying in the right direction and at the right altitude, the manager has to evaluate and review the plan. Such an exercise enables to initiate the corrective measures at the right time before it is too late. This depends on the accuracy of the information systems in the organization.

## **STEPS IN PLANNING**

Though there may be a few variations in the exact procedure adopted by different organizations in planning, the following are the broad steps:

a. **Setting of goals**

Planning begins with decisions about what the organization wants to achieve during a specified period. The goals of an organization and various subunits have to be decided and spelt out in clear terms. It is always desirable to express the goals in quantitative terms for all the key areas of the business like production, profit, productivity, market share, employee relations, social responsibilities, etc. For instance, instead of saying that the objective of business is to achieve a fair rate of return on the investment, it may be given a quantitative expression, say, 10 or 15 percent return on the investment. The time frame in which the objectives have to be achieved must also be specified. Besides, adequate attention has to be paid to the resources required to achieve the objectives. Thus what to achieve, when, how and with what resources are a few important questions that should be answered at this stage.

Since goal setting is the essential first step in planning, managers who fail to set meaningful goals cannot make effective plans. If Telco is able to retain its dominance in the Heavy Commercial Vehicle (HCV) segment, it is because all the employees of the organization know clearly that the primary objective is retaining the leadership in the industry. For instance, SAIL's corporate mission "Infrastructuring India" explains basic purpose and board objectives of the company to a larger extent. The mission of the organization, the corporate values, experience, policies provide adequate guidance to the managers in goal setting.

#### **b. Outlining Planning premises**

Planning premises, in simple, are the assumptions about the various elements of the environment. Planning assumptions or premises provide the basic framework in which plans operate. Appropriate assumptions have to be made on various aspects of the environment – both internal and external to the organization. Otherwise, it will be like fighting a battle without a clear assessment of the enemy's strengths and weaknesses.

*i. Internal premises:* Important internal premises include sales forecasts and policies of the organization. Each one of these elements is a critical success factor. For instance, the accuracy of the sales forecast influences the procurement of resources, production scheduling and the marketing strategies to be pursued to achieve the objectives. Similarly, however effective the objectives are, it is the people who have to perform and achieve. If their attitude is not positive, nothing moves.

*ii. External premises:* Important external premises relate to all those factors in the environment outside the organization. They include issues related to technology, general economic conditions, government policies and attitude towards business, demographic trends, socio-cultural changes in the society, political stability, degree of competition in the market, availability of various resources and so on.

It is evident that some of these factors are tangible while others are intangible. For example, material and human resources availability, etc. are tangible factors which can be stated in quantitative terms. On the other hand factors like political stability, attitudes of the people, certain other sociological factors are intangible, in that they cannot be

measured quantitatively. Effective premising – the making of appropriate assumptions, helps the organization to identify the favourable and unfavourable elements in the environment. Though accurate premising is difficult, anticipating future situations, problems and opportunities would undoubtedly help the managers in reducing the risk, though not completely eliminating it.

**c. Decide the planning period**

How far in the future should a plan be made is another pertinent question in the process of planning. Businesses vary in their planning periods. In some cases plans are made for a short period, varying from a few months to a year, while in some other cases, they are made to cover a longer period, to cover a period of more than a year. The period may extend up to 5-10 years and even beyond. Companies normally plan for a period that can be reasonably anticipated. The lead time involved in the development and commercialization of a product and time required to recover the capital investment (pay-back period) influence the choice of the length of the plan. Again, in the same organization, different plan periods may exist for different purposes. This gives rise to the two important concepts – operational planning and strategic planning. While operational plans focus on the short-term, strategic plans focus on the long-term.

**d. Develop alternatives and select the course of action**

The next logical step in planning involves the development of various alternative courses of action, evaluating these alternatives and choosing the most suitable alternative. Objectives may be achieved by different courses of action (alternatives). For example, technical know-how may be developed by in-house research, collaboration with a foreign company or by tying up with a research laboratory. Similarly, an organization can grow by expanding its scale of operations or through acquisitions and mergers. Technical feasibility, economic viability and the impact on the society are the general thumb rules to select the course of action. The alternative courses are evaluated in the light of the premises and the overall goals of the organization.

**e. Derivative plans**

The plan finalized after a thorough analysis of various alternatives

suggests the proposed course of action. To make it operational, it has to be split into departmental plans. Plans for the various operational units within the departments have to be formulated. The plans thus developed for the various levels down the organization are called derivative plans. For instance, production and marketing of 10,000 units of a product and achieving a return of 10 percent on the investment may be the enterprise's plan relevant for the whole organization. Its effective execution is possible only when specific plans are finalized for the various departments like production, marketing, finance, personnel and so on with clear-cut objectives to be pursued by these departments.

**f. Review periodically**

Success of the plan is measured by the results and the ease with which it is implemented. Therefore, provision for adequate follow-up to determine compliance should be included in the planning work. To make sure that the plan is contributing for the results, its review at regular intervals is essential. Such a review helps in taking corrective action, when the plan is in force.

**Why plans fail?**

Effective planning is not an easy task. There are a number of reasons for failure of plans in practice. Planning suffers from the following limitations.

**1. Cost and time**

Planning is quite a costly and time consuming process. Unlimited amount of time is spent on forecasting, evaluating alternatives etc. By the time a plan is established, the environment might change and this requires a complete revision of the plan. Besides this, cost also increases.

**2. Validity of the forecasts**

Planning is future oriented activity based on forecasts. As the period of planning increases, the accuracy of forecasting diminishes. Planning loses its value if reliable and adequate data is not available.

### 3. Inflexibility

Planning becomes rigid at times because of internal inflexibilities. This reduces individual initiative and causes delay in decision making. Internal inflexibilities like rigid policies and procedures and limited resources affect planning process.

### 4. Influence of External Factors

External factors beyond the control of an organization affect the effectiveness of planning. These are very difficult to predict and make execution of plans very difficult. External factors like government control, technological changes and trade unions affect the planning process.

### 5. Resistance to change

Another important limitation of planning is resistance to change. The human element in an organization always resists change. People are more concerned about the present rather than the future which is uncertain. Planning being forward looking is always affected by this resistance to change.

### Unrealistic plans

The entire planning process may fail, if people involved in it do not formulate correct plans. The reasons for failure of people in planning may be due to a number of reasons like lack of commitment to planning, lack of delegation of authority, excessive reliance on past experience, tendency to overlook premises, etc.

### Ensure the following when you plan!

It is an irony that at times even the best of the plans may flounder in spite of careful analysis and emotional commitment. So as to avoid the pitfalls in planning, make sure of the following;

- Set realistic and achievable goals;
- Communicate the assumptions on which plans are formulated to all the people and departments concerned;



- ▶ Encourage and make people participate in the planning program so as to ensure the right commitment;
- ▶ Ensure proper coordination between the short-term and long-term plans. They should not be viewed as mutually exclusive;
- ▶ Encourage creativity in planning. Creativity helps in identifying the best alternatives; and
- ▶ Pay attention to the resources position of the organization so as to ensure the availability as and when required.

### **Characteristics of a Sound Plan**

A sound plan should have the following characteristics:

**(a) Primacy:** Planning is an important managerial function that usually precedes other functions. Obviously, without setting the goals to be reached and the lines of actions to be followed, there is nothing to organize, to direct, or to control in the enterprise. But this should not lead us to think that planning is isolated from other managerial functions.

**(b) Continuity:** Planning is a continuous and never ending activity of a manager to keep the enterprise as a going concern. One plan begets another plan to be followed by a series of other plans in quick succession. Actually, a hierarchy of plans operates in the enterprise at any time. Planning gets used up where tomorrow becomes today and calls for further planning day in and day out. Again, the incessant changes make re-planning a continuous necessity.

**(c) Flexibility:** Planning leads to the adoption of a specific course of action and the rejection of other possibilities. This confinement to one course takes away flexibility. But if future and assumptions upon which planning is based prove wrong, the course of action is to be modified for avoiding any deadlock. Accordingly, when the future cannot be molded to conform to the course of action, the flexibility is to be ingrained in planning by way of adapting the course of action to the demands of current situations.

**(d) Consistency:** Planning is made by different managers at different times. Maintenance of consistency or the unity of planning is one of its essential requirements. Objectives provide the common focus for

unifying managerial action in planning. Moreover, policies and procedures introduce a consistency of executive behaviour and action in matters of planning.

(e) **Precision:** Planning must be precise with respect to its meaning, scope and nature. As guides to action, planning is to be framed in intelligible and meaningful terms by way of pinpointing the expected results. Planning must be realistic in scope rather than being dreams indicating pious desires. As planning errors are far more serious and cannot be offset by effective organizing or controlling, the accuracy and precision is of outmost importance.

(f) **Pervasiveness:** Planning is a pervasive activity covering the entire enterprise and every level of management. Planning is not the exclusive responsibility of top management only. But it extends to middle and lower managements as well. Although top managers are mostly preoccupied with planning because of the wider scope of operational and decision making authority, planning is of equal importance to every manager.

### **Long Range Planning and Short Range Planning**

Planning involves deciding a future course of action. Plans always has some time frame-the period in future that a plan covers. Based on the length of time involved, plans are usually classified as strategic or long range plans and operational or short range plans, strategic plans are designed to meet the broad objectives of the organisation to implement the mission that provides justification for the organisation's existence. Operational plans provide details as to how strategic plans will be accomplished. However, it must be remembered that both strategic and operational plans are not mutually exclusive, but are complimentary. We will first discuss strategic planning and then proceed to operational planning.

### **Long Range Planning / Strategic Planning**

The terms long range planning, Strategic planning, and Corporate planning are used synonymously by many authors. Strategic planning has its origin in military organizations where the objective is to envisage a variety of contingencies that may arise when large forces move into

operation. Viewed in this backdrop, strategic planning in a business organisation envisages a comprehensive study of the various external and internal parameters that affect a company in charting a course of action to achieve the goals.

### **Strategic Planning helps the Management in:**

- ▶ coping effectively with future contingencies.
- ▶ providing an early opportunity to correct mistakes.
- ▶ making decisions about the right things at the right time: and
- ▶ understanding what actions to take in order to shape the future.

George Steiner has defined strategic planning as “*the process of determining the major objectives of an organisation and the policies and strategies that will govern the acquisition, use and disposition of resources to achieve those objectives*”. Strategic plans reflect the socio-economic purpose of the organisation and the values and philosophy of the top management. In simple, they relate the organisation to the environment in which it operates by providing answers to the basic questions like:

- ▶ Where are we now?
- ▶ Where do we want to go? And
- ▶ Why do we want to go there?

Organisations in the west have been exposed to the strategic planning since long. In India, many subsidiaries of the multinational corporations made a beginning in this direction. Indian companies (Private and public sector) have also realized the importance of strategic planning, thanks to the changed realities in the last few years. As a result, every company has now begun to speak in terms of corporate mission, strategic planning and organisational vision. Strategic planning serves the following two functions.

#### **a. Anticipates Future Opportunities and Threats**

An accurate assessment of the future opportunities and threats is crucial to the success of any business. Business environment is changing so fast these days that a deliberate corporate effort is called for to keep abreast with the changes. The changes that occur may be precursors of future

threats and opportunities. The investment in large business enterprise today runs into thousands of crores of rupees. The gestation period is too long. During this period many things may change.

Effectiveness of the business organisation lies in converting the threats into opportunities. For instance, when the crude oil prices were hiked in 1973 by the OPEC countries, it created havoc on petro-based industries. Automobile companies as a result were forced to change to small fuel efficient cars. In this case, the threat was converted into an excellent opportunity. Small car thus has become the fashion of the day. Similarly, ITC in India, continuously hounded by excise levies and taxes on their main tobacco products cigarettes, had to think of diversification into hotels, paper, agro products and aquaculture – which ultimately turned out to be a God sent opportunity.

#### **b. Provide Clarity of Purpose and Direction**

As a result of the overall increase in the size of companies, the internal departments (production, marketing, finance, personnel etc.) have also become quite large. With growing specialization in each of these areas, these departments are prone to become watertight compartment giving rise to inter-departmental rifts. Corporate strategies spelt out clearly help in smoothening out some of the interdepartmental conflicts. Strategic planning provides unity of purpose and direction, the much emphasized management principle.

For example, it is not unusual, for instance, for marketing department to ask the production department to shorten their production runs, to cater to the demands of various models which is normally resisted by the latter. Similarly, the design department may often specify certain change in the product which may raise the cost of production. The finance department may try to block any measure that increases the cost of production.

The manager's success depends largely on understanding the trends in the environment. The trends contain signals and give clues about the potential opportunities and impending threats. Many organizations have paid a heavy price for their failure to draw the right meanings from the signals. In some cases, though the management is aware of the trends, a fixed mindset or resistance to change make them cling on to the status-quo.

Take the case of the public sector giant, HMT which prided itself, for a long time on its dominance in the Indian wrist watch market. The company was on a high tide for a long time and failed to understand the shift in the consumer preference towards the trendier, sleek quartz watches. It was so complacent that it took the market for granted. In the meantime much of the HMT's traditional markets have been captured effortlessly by TITAN. TITAN with its innovative marketing strategies has, no doubt, changed the face of the Indian watch market. This is only one of the several examples of failures in strategic planning in the contemporary business world.

### **Short Range Planning / Operational Planning**

Strategic planning is the prerogative of the top management which is the highest policy making body in any organisation, whereas operational planning is done at the lower levels. Strategic planning is mostly concerned with the “why” of the things, whereas operational planning is concerned with the “how” of the things. The focus in strategic planning is on long-term, while it is on short-term in operational planning. Further, planning is less detailed in the former because it is not involved with the day-to-day operations whereas it is more detailed in the latter, considering its nature, operational planning is also called tactical planning.

However, Operational plans stem or originate from strategic plans. In other words, strategic planning provides guidance and boundaries for operational planning. Effective management, therefore, must have a strategy and must operate on the day- to- day level to achieve it. Both should not be viewed as mutually exclusive because operational planning identifies the major activities to achieve the objectives of strategic planning. For example, if the strategic plan is to face competition with new and innovative products, major tasks to achieve this goal would be clarified by operational planning. The possible tasks at the operational level include:

- ▶ strengthening the research and development department;
- ▶ motivating the people to work on new products; and
- ▶ creating a climate in the organisation where people are willing to take risks.

## **Types of Plans**

Different types of plans are developed by an organisation, namely mission, strategies and policies, procedures, rules, programmes and budgets. One common thing is, they all refer to a future course of action. However, some variances in respect of the scope and operation are found in the implementation. Some are single-use plans while some are standing plans. They are discussed below:

### **Mission or Purpose**

Organisations exist in society. Therefore, it is appropriate to relate their existence to society by satisfying a particular need of the society. Mission may be defined as “*a statement which defines the role that an organisation plays in the society*”. The terms ‘mission’ or ‘purpose’ are often used interchangeably. An organisation’s mission statement includes its philosophy and basic purpose for which it exists. It establishes the values, beliefs, and guidelines that the organisation holds in high esteem. Mission statement suggests how an organisation is going to conduct its business. It defines the basic intentions of the firm. A Clear definition of ‘mission’ or ‘purpose’ is necessary to formulate meaningful objectives. Answers to two important questions are provided by the mission statement: what is our business? and what should it be? These questions force the management to define their customers and their needs.

### **Policies**

Koontz and O’Donnel define policy as “*a general statement of understanding which guides the thinking and action in decision-making.*” Policies provide the framework within which managers operate. Policies exist at all levels in the organisation. Some may be major policies affecting the whole organisation, while others may be minor or derivative policies affecting the functioning of departments or sections within the departments.

Policies are laid down by the management for all the important functional areas. As such, we hear about production policies, financial policies, marketing policies and personnel policies, to mention a few. For instance, in the personnel area, specific policies may be formulated

for recruitment, training, compensation, etc. Accordingly whenever the need for recruitment arises, the personnel manager consults the existing recruitment policy of the company and initiates the steps necessary to fill the vacancies. Thus it is evident that the personnel manager operates within the broad policy of the company in recruiting the people. Thus, policy is a one time standing decision that helps the manager in making day-to-day decisions in their operational areas.

## **Procedures**

Policies are subdivided and stated in terms of procedures – A series of related steps or tasks to be performed in a sequential way. For example: A company's policy may be to sell old stock at a discount. The procedure may explain how to decide which product is obsolete and what percentage of discount is to be offered. But procedures, if simple and clear would ensure order in the performance of operations. Though procedures exist at all levels in an organisation, they are more detailed at the lower levels. In common parlance, they are called '*Standard Operating Procedures*' (SOPs).

Procedures for placing orders for material and equipment, for sanctioning different types of employee's leave, for handling grievances at the shop floor level, etc., suggest how each of these has to be handled. Policies and procedures are closely interrelated. For instance, a company may follow time-bound promotion policy to promote people from within. But the operational part of the policy is specified by the procedure – the formalities to be fulfilled to effect the promotion are dictated by the procedure.

## **Rules**

A rule is also a plan. A rule is a prescribed course of action that explicitly states what is to be done under a given set of circumstances. Rules are plans in that they suggest the required actions. A rule requires that a definite action has to be taken in a particular way with respect to a situation. Some definiteness is associated with rules. For example, 'no smoking' is a rule. The essence of the rule is that it reflects a managerial decision that certain actions be taken – or not be taken.

Rules should not be confused with policies and procedures. Policies contain some operational freedom or discretion while rules allow no discretion in their application. Similarly, procedures though different from rules may contain rules regarding the do's and don't's. For example, there may be a procedure to attend to customer grievances in respect of post-sale service. The procedure may contain a rule that free service is available only for a period of two years after the sale.

### **Programs**

A programme is a broad term which includes goals, policies, procedures, rules and steps to be taken in putting a plan into action. Terry and Franklin define program as *"a comprehensive plan that includes future use of different resources in an integrated pattern and establishes a sequence of required time schedules for each in order to achieve stated objectives"*. Thus, a programme includes objective, policies, procedures, methods, standards and budgets. For instance, launching Prithvi satellite is a program "Jawahar Rojgar Yojana" is a programm. Program may be major or minor. For instance, a company may embark upon modernization program of the plant and machinery and other manufacturing systems in a big way. By all means such an effort is a major program. Similarly, a large organisation may start computerizing all its activities. On the other hand, modernisation of small equipment in some section of the factory and computerization of a particular operation in a certain department may be considered as a minor program.

### **Budgets**

A budget is a plan statement for a given period of time in future expressed in financial or physical units. Budget contains expected results in numerical terms. A budget is a quantitative expression of a plan. Organizational budgets vary in scope. Master budget which contains the consolidated plan of action of the whole enterprise is in a way the translated version of the overall business plan of the enterprise. Similarly, production budget represent the plan of the production department. Again, capital expenditure budget, raw material budget, labour budget, etc. are a few minor budgets in the production department. One of the advantages of budgets is they facilitate the comparison of actual results with the planned ones by providing yardsticks for measuring performance.



## Review Questions

1. What is planning? Explain the objectives and principles of planning.
2. Explain the planning process.
3. Distinguish between long range and short range planning?
4. What are the different types of plans? Explain them.
5. "Failure to plan is planning to fail". Discuss.
6. Take any two Indian companies and examine how they have succeeded or failed due to poor strategic planning.
7. Identify and explain the strategic planning process in an MNC like Google drawing from the public domain.

\*\*\*



---

## Lesson – 6 : MANAGEMENT BY OBJECTIVES

---

### Objectives

*After reading this lesson, you should be able to:*

- Familiarize Yourself With The Process Of Mbo;
- Understand The Usefulness Of Mbo As A Managerial Tool;
- Understand The Sources Of Polices;
- Acquaint With The Formulation Of Polices; And
- Explain The Appropriateness Of Business Strategy.

### Lesson Outline

- Process Of Mbo
- Prerequisites Of Mbo
- Advantages Of Mbo
- Reasons Why Mbo Fails
- Types Of Policies
- Principles Of Policies
- Policy Formation
- Strategies
- Appropriateness Of Business Strategy
- Review Questions

Management guru Peter Drucker is credited with being the first to introduce Management by Objectives (MBO) as an approach for increasing organizational effectiveness. He observes that every manager, from the highest to the lowest levels in the organisation, should have clear objectives to pursue. According to him, such a process would enable each manager to have a clear understanding of what the organisation expects of him or her and how their individual objectives are integrated with the overall organizational objectives. George Odiorne has done substantial research work on MBO and further popularized the concept.

To quote George Odiorne, “MBO is a process whereby the superior and subordinate managers of an organisation jointly identify the common goals, define each individual’s major areas of responsibility in terms of the results expected of him, and use these resources as guides for operating the unit and assessing the contribution of each of its members”.

Different goals are sought to be achieved by the introduction of MBO in organizations. MBO, as a management tool, thus, is so versatile that it is used;

- ▶ to integrate the organizational goals with the individual goals;
- ▶ as a motivational technique wherein individuals are driven towards the achievement of goals;
- ▶ to appraise the performance of managers; and
- ▶ to control the activities as they are performed.

Drucker suggests that objectives are to be specified in the key result areas of business (KRAs). A key result area may be understood as one the performance of which, directly and vitally affect the success and survival of the business. Accordingly, for a manufacturing firm production, productivity, profitability, market share, social responsibilities, employer and employee relations, manager and worker development, development of physical resources, constitute the important key result areas. It may be understood that the KRAs vary from business to business. Since MBO involves a systematic effort towards the achievement of objectives, utmost care has to be exercised in setting the objectives for all the key result areas.

### **Prerequisites of MBO**

- ▶ MBO is not merely a goal-setting tool. It is a philosophy and has to be understood thoroughly by the managers concerned with achievement of objectives.
- ▶ Top management must be willing to implement the system wholeheartedly. Its support and encouragement are crucial for the success of MBO. The necessary democratic climate has to be created in the organisation for setting the goals in a realistic way.
- ▶ Goals have to be spelt out in specific and clear terms. To the extent possible, they must be made realistic because goals motivate employees towards better performance.

- ▶ The key result areas (KRAs) of the business have to be identified and appropriate goals have to be specified for these areas. All the important areas of the business must be covered with meaningful goals.
- ▶ It has to be realized that goal-setting in the MBO process is not an end by itself. It is only a means to achieve organizational effectiveness. Otherwise, goal-setting becomes the primary task rather than their achievement.
- ▶ Appropriate organisation structure has to be designed with well-understood relationships among people such that every goal becomes some individual's responsibility.
- ▶ Besides clarifying the organizational roles by adopting a suitable organisation structure, attention has to be paid on the resources required by the people to achieve the goals. Otherwise, goals by themselves, however effective they are, do not assure performance. Performance depends on the timely availability of resources. Non-availability or inadequate access to the resources frustrates the individuals concerned with the achievement of goals.

### **Nature of Objectives**

'Objectives' are the end points of management action. They provide meaning to the existence of an organisation. Objectives are the specific targets to be achieved by an organisation. They are the end-points towards which all management activities like organising, staffing, directing and controlling are directed. In other words, only after defining the basic objectives for which an organisation exists, can the manager determine the kind of organisation, the type of personnel and their skills, the kind of motivation and direction and the nature of control techniques which may be employed to achieve the ends.

1. **Objectives may be in quantitative or qualitative terms.** For example, in the areas of market standing, productivity and physical and financial resources quantification is possible. On the other hand, worker's morale, social responsibility, etc. cannot exactly be quantified. However, objectives in the latter category may be expressed in qualitative terms. Thus, quantitative objectives are gauged by '*how much*' while qualitative objectives by '*how well*'.

2. **Objectives have hierarchy** in that objectives which have wider scope and are relevant for the whole organisation are known as enterprise objectives. These objectives are split into unit level or departmental objectives. Thus, objectives at all levels in the organisation are interrelated and form a network.
3. **Short-term and Long-term Objectives:** Short-term objectives are those which are sought to be achieved by the organisation in the immediate future, while long-term objectives are those which are aimed to be achieved over a longer period, say five to ten years or even more. However, both are not mutually exclusive and are interrelated.
4. **Objectives sometimes may be in conflict with each other** as the goals of the various departments at times may clash. Each department considers that its goals are more important. For example, the production goal of low unit cost achievable through mass production may be in conflict with the sales goal of offering high quality goods. Such conflicts have to be resolved amicably.

### **Process of MBO**

Having understood the basic characteristics of the objectives, let us examine the process of MBO. As a process, management by objectives begins at the top of the organisation with the establishment of specific organizational objectives. Subsequently, objectives at various levels down the hierarchy are decided by mutual discussions and consultations by both superiors and subordinates.

#### ***The process of MBO includes the following steps:***

- ▶ establishment of goals for the whole organisation,
- ▶ preparation by subordinates, of specific goals within the framework provided by the superior,
- ▶ joint discussion of an agreement upon the goals by the superior and subordinate,
- ▶ joint review of progress at regular intervals in the light of the predetermined goals, and
- ▶ corrective measures, if necessary, as revealed by the review.

In the whole process, setting of goals for the subordinate positions is the crucial step. Unlike in the traditional system where goals are decided for the subordinates by the superiors, in the MBO system, goals are set on the basis of consensus reached in the discussions between superiors and subordinates. They are set in a democratic way. Superiors act as facilitators and create a favourable climate where subordinates freely express their opinions, viewpoints and perceptions about what they believe could be achieved. The process ensures meeting of minds between superiors and subordinates. As a result, there is ample possibility for the subordinates to feel that they are working for their own goals and not for somebody else's. Consequently, they strive to achieve the goals. As they participate in the goal setting exercise actively, they in turn get motivated to achieve them. Once they achieve the goals, that contributes for the satisfaction of their ego needs. Thus, MBO serves as a motivational technique.

### **Advantages of MBO**

An organization can benefit in the following ways by implementing MBO.

- ▶ Accomplishes consistency in objectives as each department's objectives are consistent with the organizational objectives, the possibility for the various departments working at cross purposes is very less.
- ▶ Contributes for effective management by providing lot of clarity in the objectives and the organisation that is necessary to achieve them;
- ▶ Forces the management to plan the activities in a systematic way.
- ▶ Facilitates objective performance appraisal. As the goals themselves become the standards against which the actual performance is measured, MBO system itself acts as an effective performance appraisal tool.
- ▶ Contributes for the installation of a democratic and participative setup essential for the success of an organisation in a complex business environment of today. The interaction that takes place between the superiors and subordinates is a good sign of human resource development in the organisation.

## Reasons why MBO Fail

In spite of many advantages, MBO may not be considered as a panacea for all the evils of the organisation. The success of the program depends on several factors. If the program fails, it is largely due to the following reasons:

- ▶ Lack of top management involvement and support. For an MBO program to succeed, it must have the complete support of top management.
- ▶ Lack of understanding of the philosophy behind MBO. MBO program in some organizations meet the resistance of employees because it is imposed on them as 'control device' to curb their freedom.
- ▶ Difficulty in setting realistic and meaningful objectives. Some jobs and areas of performance cannot be quantified and hence are not amenable for objective evaluation.
- ▶ Increased time pressure. To use MBO program, managers must learn to establish priorities and use the time effectively.
- ▶ Lack of relevant skills. Managers may not have the requisite skills for identifying objectives, communication and interpersonal interaction such as counseling and receiving feedback.
- ▶ Lack of individual motivation. The rewards and incentives for superior performance have to be specified clearly. Ambiguity or uncertainty regarding the outcome of the efforts is one of the reasons for the non-performance.
- ▶ Poor integration with other systems. Objective setting and review phases must be performed in conjunction with other activities such as budgeting, forecasting and the like. Often managers are neither taught how to set the objectives nor familiarized with the various plans and policies of the organisation. In such cases, each department ends up going its own way, and the results are counterproductive to the overall organisation.



## **Review Questions**

1. Explain the characteristics of objectives and how well defined objectives influence business success.
2. Distinguish between short term and long term objectives.
3. Explain the process of Management by Objectives. Also bring out the relative merits and demerits of MBO.
4. Explain how you go about in installing the MBO program in a fast growing medium size organisation.
5. Do you subscribe to the view that MBO is a Pan-Asia for organisational ills?

\*\*\*



---

## Lesson- 7 : Policies

---

### Objectives

*After reading this lesson, you should be able to:*

- Understand The Concept And Importance Of Policies;
- Explain The Various Sources Of Policies;
- Acquaint With The Formulation Of Policies; And
- Explain The Appropriateness Of Business Strategy.

### Lesson Outline

- Types Of Policies
- Principles Of Policies
- Policy Formulation
- Strategies
- Review Questions

Decision-making is the primary task of a manager. While making decisions, it is common that managers consult the existing organizational policies relevant to the decisions. Policies provide the basic frame work within which managers operate. Policies exist at all levels in the organisation. Some may be major company policies affecting the whole organisation while others may be minor in nature affecting the departments or sections within the departments. Thus, policies are, intended to provide guidance to managers in decision-making. It may be remembered that a policy is also a decision. But it is a one time standing decision in the light of which, so many routine decisions are made.

### TYPES OF POLICES

Polices come into being in any organization in different ways. Koontz and O'donnell have classified policies under the following types, based on their source.

### **1. Originated Policies**

Top management formulates policies for the important functional areas of business such as Production, Marketing, Finance, Personnel and so on. The objective is to help the concerned managers in decision making in their respective areas. Thus, originated policies are the result of top management initiative. These policies are formulated in the light of organizational objectives. They may be broad or specific depending on the centralization or decentralization of authority. If they are broad, they allow the subordinates some operational freedom. On the other hand, if they are specific they are implemented as they are.

### **2. Appealed Policies**

Managers quite often confront with peculiar situations as to whether they have the authority to take a decision on a particular issue or problem. The policies regarding some issues may be unclear or may be totally absent. There may not be precedents to guide the manager. In such a case, he appeals the matter to the superiors for their thinking. Thus, appeals are taken upwards till they reach the appropriate level in the hierarchy. Depending upon the nature of issues involved, after a thorough examination, policy decision would be taken at the appropriate level. The decision taken by the higher-ups becomes a policy. For example, during festival seasons, the manager at the branch level may be in a dilemma to offer discount to the customers. There may not be any explicit policy to guide him. But to meet competition in the market management, on the basis of an appeal made by the branch manager may allow him to offer discount on such occasions. Unless otherwise stated, it becomes an unwritten policy and guides the manager's decision making in all such future situations.

### **3. Implied Policies**

In some cases, there may not be specific policies for all the contingencies. Managers draw meanings from the actions and behaviour of their superiors. For example, if customer service is on top of the agenda of the organisation and if such a philosophy is constantly reinforced by the actions of top management from time to time, a manager may go all out to help a customer who is in a difficult situation. There may not be any

objection from the top management to the stand taken by the lower level manager in support of the customer. Though there is no explicit policy, managers may assume it in a particular way and go about in their day-to-day operations.

#### **4. Externally Imposed Policies**

These are the policies which are not deliberately conceived by the managements. They are rather imposed on the organizations by the agencies in the external environment like government, trade unions, industry associations, consumer councils, etc. These agencies, in order to protect the interests of the respective groups may lay down certain policies to be followed by the business. As the interaction of the business with external environment is increasing, one can find many policies thus coming into being. The organization has to obviously comply with them. For instance, the recruitment policy of the organisation is influenced by the government's policy towards reservations to weaker sections. Anti-pollution measures, concern for the quality of the product and customer service also fall in this category.

### **Importance of Policies**

#### **Provide the Framework for decisions**

Policies provide the broad framework within which decisions are made. In the absence of appropriate policies, managerial decision-making may be analogous to "*reinventing the wheel*" every time. For example: a policy on internal promotions greatly helps the manager in filling the vacancies. Whenever vacancies arise, he simply goes by the existing promotion policy of the organisation. Sound policies thus save lot of time in decision-making and avoid confusion.

#### **Ensure Consistency in Operations**

Policies specify the boundary conditions of decisions. When decisions are actually made, they conform to the policy relevant to the decision. If the policy of an organisation is to face competition with quality products, the emphasis naturally will be on issues related to improving the quality of the product. All the decisions that affect the product quality

are normally taken in the light of the explicit policy. Policies developed carefully and understood perfectly results in consistency in planning.

### **Principles of Policy Making**

Policies help to ensure that all units of an organisation operate under the same ground rules. They facilitate coordination and communication between various organizational units. This is possible because policies make consistency in action. In view of the importance of policies in guiding executive behaviour, they need to be formulated carefully. In fact, policy formulation is one of the important executive responsibilities. Effectiveness of policies, therefore, lie in understanding the following principles.

#### **1. Define the Business**

The two fundamental questions to be asked in this regard are what is our business? What should it be? Many businesses have failed because they did not attempt to seek answers to these simple and basic questions. Gramophone record companies for long did not realize that they are in the entertainment business. Hence they are now here in the corporate history. In contrast, Hallmark Incorporation of USA defines its business as “social expression” and not as greeting cards. Such a definition helped the company a lot in expanding operations in the related fields like personal accessories and women’s jewellery, etc. To define the business, a company must take a close look at its basic operations and analyze it’s major strengths and weaknesses in all the functional areas like marketing, product development, finance and public relations. Such an exercise enables the enterprise to capitalize on its strengths while overcoming the weaknesses.

#### **2. Assess Future Environment**

A realistic estimate of the future trends in matters related to technology, economic and market conditions, political stability, etc., is essential for policy formulation. Instances are not rare, where the best of the forecasts turned out to be just intentions. That is why for some managers, forecasting is a highly unpleasant task. It is interesting to note that sometimes products which were predicted to be instant failures by the

so called market surveys proved to be runaway successes. The 'sintex' water tank is a classic example where the product defied the gloom predicted by the experts. However, examples of this sort are few and far between. On the other hand, quite the opposite is also possible.

### 3. **Ensure availability of Resources**

While formulating policies the resources required to implement the policies have to be assessed. If policies are formulated without regard to the ground realities, you would encounter too many problems while implementing the policies. As a result, policies do not serve the intended purpose. For example, if the policy of the organisation is to cash in on the new opportunities, it does not mean that you can enter any field thrown open by the government. You have to assess yourself as to how strong you are in terms of resources required. Otherwise it amounts to overstretching. That is how, "*close to the knitting*", building on "*core – competencies*" are very much talked about these days.

### 4. **Communicate the Policies**

If policies are to serve the desired purpose, they have to be communicated to all those who are to implement them. The policy of the organisation towards competition, for instance, has to be communicated to the people in the marketing department. Otherwise there will not be proper synchronization between the policy and action.

## **Policy Formulation**

As mentioned earlier, the basic intention of policies is to help executive thinking in decision-making. Policies are formulated for all the key functional areas of business like production, marketing, finance, personnel and so on. Effectiveness and consistency of decisions in all these areas depend on how well the policies are formulated and understood. A policy is a plan. Therefore, the steps involved in policy formulation are similar to the steps in planning. Though policies vary in respect of scope, the process of policy formulation usually involves the following steps.

**a. Corporate Mission**

Corporate mission specifies the purpose for which the organisation exists. It relates the organisation to the environment in which it operates. It is natural, therefore that all the activities of the organisation are geared towards the achievement of the mission. The mission statement provides the direction to the organisation. As such, thorough understanding of the corporate mission is the starting point for policy formulation.

**b. Appraisal of the Environment**

Environment appraisal in a systematic way is the key for successful formulation of the policies. Correct appraisal of the environment enables the organisation to integrate its activities with the needs of the society. As such, the nature of the environment, the various dynamics of it have to be analysed. It includes collection of relevant information from the environment and interpreting its impact on the future of organisation.

**c. Corporate Analysis**

While the focus in environmental appraisal is on the internal factors of the business, corporate analysis takes into account the internal factors. Corporate analysis discloses strengths and weaknesses of the organisation and points out the areas that have potential. This is an inward looking exercise.

**d. Identification of Alternatives**

The above two steps – environmental appraisal and corporate analysis popularly known as SWOT (Strengths, Weaknesses, Opportunities and Threats) analysis will help identifying the alternative policies. For example, the objective of the organisation is expansion. This may be achieved by several ways, diversification of the activities, acquisition of existing businesses, and establishment of subsidiaries abroad and so on. Again, if diversification is chosen, it has to be decided whether it is into related or unrelated business. The alternative policies thus identified have to be evaluated in the light of the organizational mission and objectives.



e. **Choice of the Right Policy**

This stage involves choosing the right policy from among the several policy options that suits the organizational objectives. The Corporate history, personal values and attitude of the management and the compulsions in the environment, if any, influence the choice of the policy.

f. **Policy Implementation**

Effective implementation of the policy requires designing suitable organisational structure, developing and motivating people to contribute their best, designing effective control and information systems, allocation of resources, etc. At times, policies may have to be revised in line with the changes in the environment. Further, Policies need to be monitored constantly during the implementation stage so that inadequacies if any, may be corrected at the appropriate time.

**Major Areas of Policy Making**

As mentioned earlier, policies are normally formulated for all the key areas of the business. Some of the important areas for which policies are required are discussed here.

**Production**

Out-sourcing has become the order of the day where in many companies are producing the components from other companies. Thus, in the area of production, make or buy decision is an important policy. For instance, automobile companies buy many accessories and parts from outside rather than making those parts themselves. This type of policy enables the organization to concentrate on the basic product. However, it depends largely on the resources of the organization and how well the companies maintain the relationships with the vendors.

Another important policy pertains to the *production run*. The volume of output depends on the production run. The demand for the product in terms of orders, costs of tooling, economies of scale are some of the factors that influence the production run. some companies choose to

produce them in order .while some companies may produce in anticipation of demand, during slack season, there are companies which produce some fill-in-products to make good use of facilities. Issues relating to innovation, new product development and diversification are the other important aspects which require policy direction.

## **Marketing**

As the business world has become increasingly competitive, marketing has acquired tremendous importance in the recent times. Peter Drucker regards innovation and marketing as the two important functions for every business. The success of any organization therefore depends on how strong it is in these two basic functions. In the area of marketing, answers to such basic questions help in formulating the politics. The questions include;

1. Who are our customers and what do they buy?
2. Why do they buy our product?
3. What do we offer in relation to our competitors?
4. What supporting services do we offer?
5. What is the price to be charged?

Appropriate answers to these questions help in deciding the product, pricing, distribution, and promotional policies of the firm. Among these, pricing policy is our utmost significance. Issues related to how to face the competition are resolved with a sound pricing policy. For instance, weather to indulge in price competition or non-price competition are the two basic issues in this regard. In the former case the firm meets competition by cutting the prices while in the later, competition is met by promotion, advertising, and after sales service, etc. the emphasis is on non-price variables.

## **Finance**

Financial aspects normally set the limits to the expansion of the business. The required funds for the business may be furnished by the owners or borrowed from outside sources. The actions of management with regard to procurement, utilization and distribution of funds are guided by the broad politics laid down for the management of funds.

Important policy decision pertains to the proportion of the equity to the debt capital. The relative merits and demerits in raising the funds through equity and debt as been examined. Further in the case of a growing concern, funds may also be raised through retaining a portion of the profits in the business. This in turn influences the dividend policy of the organism.

Working capital management is another area which requires policy direction. Adequate working capital is necessary for any business for maintaining credit and meeting obligations. Policies regarding working capital vary from company to company depending upon the size and nature of the business. For instance, public utility concerns with regular cash collection may need less working capital than those engaged in the manufacture of specialized machines. Similarly, a company operating on strictly cash basis requires less working capital than one operating on predominantly credit scales.

Policies relating to the distribution on profits of the business are equally important. This is equally influenced by factors including the desire of the shareholders, the company's future plans of expansion, availability of other sources of obtaining capital, the urgency of the need for additional capital and availability of re-investable profits. If multinational companies like Hindustan lever, Brooke bond, Colgate etc., enjoy tremendous investor clout and emerged as blue chip companies, it is because of investor friendly policies relating to dividends and frequent capitalization of resources.

## **Personnel**

Any organization can be as effective as the people in it. Many problems in the organizations are obviously people related in nature. It is therefore, needless to say that sound personnel policies ensure good employer and employee relations. Important policies in this area relate to recruitment and training, compensation and other employee benefits and the attitude of the management towards labor unions. All these policies are normally influenced by factors such as skills required at various levels, the attitude of the people towards work and the philosophy of the management. On the whole, good employee-oriented personnel policies encompassing the above mentioned issues would contribute to employee

motivation and morale.

## **Strategies**

The terms '*strategy*' has been adopted from war and is being increasingly used in business to reflect broad overall objectives and policies of an enterprise. In the context of business, strategy refers to the firm's overall plan of dealing with its environment. Strategies most often denote a general programme of action and deployment of resources to attain comprehensive objectives. Strategies are plans made in the light of the competition because modern business enterprise operates in a competitive environment. They are a useful framework for guiding enterprise thinking and action. For instance, a company may follow a strategy of charging a lower price or using more sales force than competitors and advertising more heavily than competitors.

The purpose of strategies is to determine and communicate, through a system of major objectives and policies, a picture of what kind of enterprise is envisioned. They do not attempt to outline exactly how the enterprise is to accomplish its objectives since this is the task of countless major and minor supporting programmes. But they are a useful framework for guiding enterprise thinking and action.

## **Appropriateness of Business Strategy**

A business strategy is a pragmatic plan of action to achieve certain objectives. In order to evaluate its appropriateness the following comes in handy:

1. ***Internal Consistency:*** A business strategy in a particular area of business should be consistent with strategies in other areas and objectives and policies of business. Internal inconsistency in any strategy will create problem in its implementation.
2. ***Consistency with Environment:*** A strategy is basically an enterprise's response to cope with external environmental variables. Therefore, it should aim at meeting the threats and pressures of external forces.

3. ***Appropriateness in the light of available Resources:***

Formulation of a strategy requires a realistic assessment of the resources of the enterprise—men, money and materials—both existing resources and the resources it can command. The resources of an enterprise also include the skills of management and other manpower, command over sources of scarce raw materials, production facilities, technology, marketing capabilities and image, and so on. It is desirable that the every enterprise formulates its strategy within the limitations imposed by its resources. The objective is to ensure that the enterprise's resources are not over-stretched or over-strained on the one hand and to utilize the existing and commendable resources in the best possible manner on the other.

4. ***Acceptable degree of Risk:*** Any major strategy carries with it certain element of risk and uncertainty because it covers a long future horizon and because it seeks to cope with complex environment. The degree of risk inherent in a strategy should be within the bearable capability of the enterprise. Resources should not be committed irrevocable, nor should they be concentrated on a single or narrow range of ventures. Also, there should be a match between risk and returns, financial and otherwise.

5. ***Appropriate Time Horizon:*** Time is the essence of any strategy. While a reasonably long time span imparts some flexibility, the problem has to be reckoned with, however, of forecasting is ever present. How far in the future can top management predict with credibility is a measure of its capability. An optional time span cannot be mathematically determined; it is a matter of environmental conditions, the objectives to be sought and the judgment of management.

6. ***Workability:*** A strategy should be feasible and produce desired results within the constraints and parameters known to the management. It should be realistic and relatively simple to understand and implement. Certain quantitative measures like volume of sales and profit, growth rate, asset formation, market share, introduction of new products and so on are to be set. These are to be combined with qualitative criteria like the degree of confidence with which managers implement the strategy, the extent to which major areas of

decision situations are handled by reference to the criteria embedded in the strategy, the extent to which opportunities are exploited, threats averted, resources mobilised, and environmental control gained.

### **Review Questions**

1. Examine how policies influence decision making behaviour of a manager.
2. Explain the different types polices and their sources.
3. Explain how policies are formulated in general.
4. Take any functional areas of business of your choice and highlight the major areas that you would formulate policy.
5. Distinguish between polices and strategies.

\*\*\*

---

## **Lesson -8 : Decision Making**

---

### **Objectives**

*After reading this lesson, you should be able to:*

- Understand The Meaning And Characteristics Of Decision Making;
- Explain The Types Of Decisions;
- Examine The Process Of Decision Making; And
- Understand The Techniques Of Decision Making.

### **Lesson Outline**

- Types Of Decisions
- Decision Making Process
- Techniques Of Decision Making.
- Review Questions

It is said that decisions are the principal diet on which a manager thrives. It is decision-making power which distinguishes a manager from others in an organization. Hardly a day passes without making some decision or other in the executive's life. Whatever a manger does, he does through making decisions. As such, decision-making constitutes the most exciting and eventful part of any executive's career. Considering the importance of decision-making some authors even view it synonymously with management.

In the course of managing an organisation, the manager is confronted with several problems which require immediate and appropriate solutions. Such problems are solved by making decisions. For instance, break-down of machinery, customers' complaint on quality, delay in collection of receivables, some industrial relations problem at the shop-floor level leading to unrest among the employees, just to mention a few call for timely solutions. That apart, in some cases, though there is no

any problem as such – to increase productivity, market share, profitability, some major decisions have to be taken. Thus, a manager has to make decisions covering several aspects of the organisation.

Decision-making in simple may be defined as “*the selection of a future course of action from among various alternatives*”. It presupposes the existence of various alternatives. It is in a way a choice between alternatives. In other words, if there are no alternatives, there is no choice. Therefore, the question of decision-making and the associated dilemma do not arise. Thus, the following characteristics emerge from the definition of decision-making.

### **Characteristics**

- ▶ Decision making is a continuous process
- ▶ It involves a choice and therefore presupposes the existence of alternatives
- ▶ Decision making is always purposive in that decisions should aim at achieving some purposes
- ▶ It is an intellectual process supported by sound-reasoning and judgment
- ▶ Decision-making is all pervasive in the sense that all levels of managers take decisions, though at the impact and scope of decisions vary.

### **Type of Decisions**

Decisions taken by managers may be classified under various categories depending upon the scope, importance and the impact that they create in the organisation. The following are the different types of decisions:

#### **1. Programmed and Non-programmed Decisions**

Programmed decisions are normally repetitive in nature. They are the easiest to make. Usually these decisions are taken in consultation with the existing policy, rule or procedure which are already laid down in the organisation. For example: making purchase orders, sanctioning of



different types of leave, increments in salary, settlement of normal disputes, etc. Managers in dealing with such issues of routine nature usually follow the established procedures.

On the other hand, non-programmed decisions are different in that they are non-routine in nature. They are related to some exceptional situations for which there are no established methods of handling such things. For example: Issues related to handling a serious industrial relations problem, declining market share, increasing competition, problems with the collaborator, growing public hostility towards the organisation fall in this category. Problems like these have to be handled in a different way. While different managers reach the same solution in the case of programmed decision because they are guided by the same policy or procedure, the solutions may widely differ in the case of non-programmed decisions. As one moves up in the hierarchy, many of the decisions that managers make are non-programmed in nature.

It is important to note that the effectiveness of a manager lies in handling exceptional situations. Such situations call for ingenuity and sound judgment. Surprisingly, many managers get bogged down in the routine issues at the cost of the non-routine issues. The saying that “routine drives out the non-routine” instead of the other way round is true in many organizations. Such a tendency results in devoting less time for the important issues.

## **2. Operational and Strategic Decisions**

Operational or tactical decisions relate to the present. The primary purpose is to achieve high degree of efficiency in the company's ongoing operations. Better working conditions, effective supervision, prudent use of existing resources, better maintenance of the equipment, etc., fall in this category. On the other hand, expanding the scale of operations, entering new markets, changing the product mix, shifting the manufacturing facility from one place to the other, striking alliances with other companies, etc., are strategic in nature. Such decisions will have far reaching impact on the organisation. Usually, operating decisions do not need intensive deliberations and huge resources and are taken by managers at the lower levels while strategic decisions require extensive deliberations and huge resources and are taken by top level managers. The focus in the operational

decisions is on the short-run or immediate present, while it is on the long-run in the case of strategic decisions.

### **3. Organizational and Personal Decisions**

Decisions taken by managers in the ordinary course of business in their capacity as managers relating to the organizational issues are organizational decisions. For example: decisions regarding introducing a new incentive system, transferring an employee, reallocation or redeployment of employees etc. are taken by managers to achieve certain objectives. As against such decisions, managers do take some decisions which are purely personal in nature. However, their impact may not exactly confine to their selves and they may affect the organization also. For example: the manager's decision to quit the organization, though personal in nature, may impact for the organization.

### **4. Individual and Group Decisions**

It is quite common that some decisions are taken by a manager individually while some decisions are taken collectively by a group of managers. Individual decisions are taken where the problem is of routine nature, whereas important and strategic decisions which have a bearing on many aspects of the organisation are generally taken by a group. Group decision making is preferred these days because it contributes for better coordination among the people concerned with the implementation of the decision.

Decisions may also be further classified under major and minor decisions and simple and complex decisions. However, a detailed description of these types is not necessary because they are almost all similar to the already discussed programmed and non-programmed decisions in respect of importance and impact.

### **Steps in the Decision-making Process**

Rational decision-making process contains the following steps:

**a. Define the Problem**

Problem definition is the most crucial step in the entire decision-making process. As the saying goes, “*a problem well defined is a problem half-solved,*” utmost care has to be exercised in this stage for wrong definition of the problem leads to wrong solutions. This is also called diagnostic stage. Jumping to conclusions on the basis of certain symptoms has to be avoided. The problem has to be examined from different angles so as to identify the exact causes. Unless exact causes are identified, right decisions cannot be taken.

**b. Analyze the problem**

The problem has to be thoroughly analysed. The past events that contributed to the problem, the present situation and the impact of the problem on the future have to be examined. Problems do not crop up overnight. The genesis of the problem and the various contributing factors need to be analysed. In analysing the problem, personal prejudices have to be avoided. As far as possible, an objective assessment of the situation is useful to arrive at right decisions.

Proper analysis of the problem helps the manager to assess the scope and importance of the problem. If the problem is of minor nature, he can authorize his subordinates to solve it. If it is a major problem requiring the involvement of many people, he can initiate the necessary steps. Interestingly, at times some of the problems may not warrant any decision. Leaving the problem as it is could be the better option.

**c. Develop Alternatives**

There are hardly few problems for which there are not many alternatives. Effective decision-making depends on the development of as many alternative solutions as possible. The underlying assumption is that a decision selected from among many alternatives tends to be a better one. The ability to identify and develop alternative courses of action depends on the manager’s creativity and imagination. As the thinking of two people may not be similar, the skills and abilities in developing alternatives significantly vary from one manager to the other.

#### **d. Evaluate Alternatives**

The next step in the decision-making process involves evaluation of the alternative courses or solutions identified to solve the problem. Alternatives have to be evaluated in the light of the objectives to be achieved and the resources required. Evaluation involves a through scrutiny of the relative merits and demerits of each of the alternatives in relation to the objectives sought to be achieved by solving the problem.

#### **e. Select and Implement the Decision**

Scientific evaluation of the alternatives reveals the acceptability of various alternatives. After weighing the pros and cons in detail, the best alternative has to be selected and implemented. It may not always be possible to select the best alternative for a given problem for want of complete information, time and resources. In such a case, the manager has to satisfy with limited information and optimize the yields under a given set of circumstances.

Once an alternative is selected that becomes the decision and it has to be implemented in a systematic way. The required resources for the implementation and the necessary cooperation from the people concerned with or affected by the decision have to be ensured. Otherwise, however good the decision may be, it may encounter stiff resistance in the implementation stage.

#### **f. Follow-up and Feed back**

Once the decision is implemented, it has to be closely monitored. Adequate follow-up measures have to be taken. In the course of implementation, so many unexpected events may render the decision ineffective. The decision may not yield the desired results. Constant follow-up helps to take corrective measures as and when necessary. Further, such a follow-up enables to identify the shortcomings or negative consequences of the decision. It provides valuable feed-back on which the decision may be reviewed or reconsidered.

## **Rationality in Decision-Making**

Rationality in decision making implies maximization of the values in a given situation by choosing the most suitable course of action. Rationality refers to objectivity in the development of alternatives and the final selection of an alternative to achieve the desired goal. Though it is very much desirable, for a variety of reasons complete rationality is not always possible. That is the reason why people prefer to take satisfactory decisions instead of ideal or optimum decisions. In reality they confine themselves to a few important alternatives which have limited risks combined with favourable consequences. Following are the major reasons that stand in the way of rational decision-making process:

- ▶ Because of time and cost constraints, all complex variables that have a bearing on decision cannot be examined fully. Hence, the decision-maker is forced to strike a balance between the ideal and real situations.
- ▶ Since decisions are related to future, managers cannot foresee all the future consequences accurately.
- ▶ Human factors like value systems, perceptions, prejudices, social factors, etc., may enter the decision making process. Managers, being human beings, are greatly influenced by their personal beliefs, attitudes and bias.

## **Barriers in Decision-Making**

In addition to the above factors, the various barriers in organization structure also influence the decision-making process. These barriers impede the process of identification of problem, its analysis and the development of the solution. Elbing has identified some of the important barriers that can block managerial effectiveness in choosing the most suitable decision. Some of them are listed below:

- ▶ The tendency to respond to the problem instantaneously without proper information and thinking.
- ▶ The tendency of human-beings to evaluate a given problem with pre-conceived notions acts as a stumbling block in understanding the real situation.
- ▶ The tendency to resist new and innovative solutions. This is

known as the love for 'status-quo'.

Awareness of the above factors will surely help the managers in arriving at pragmatic decisions. The following suggestions can be offered to overcome the above barriers.

- ▶ Avoid premature evaluation.
- ▶ Initiate impartial probing by avoiding personal bias on the outcome.
- ▶ Develop a sound system that can supply adequate information for making decisions.
- ▶ Encourage group leaders to respond to a given situation and compare the pros and cons of the solutions offered by the two groups for making an effective decision.
- ▶ Encourage innovative thinking among the subordinates so as to identify the crux of the problem without waste of time and money.
- ▶ When decisions of critical and pivotal in nature are to be taken, encourage group thinking. For this, the problem is to be presented to the group members first and they are asked to develop as many solutions as possible in a free environment.

### **Techniques of Decision-Making**

Now-a-days, different techniques are used by managers in making decisions. These techniques, if used properly, would contribute for the effectiveness of the decisions. Some of the important techniques are discussed below.

1. **Brainstorming:** Brainstorming is the oldest and widely followed technique for encouraging creative thinking. It was originally developed by A.F. Osborn. It involves the use of a group. The success of the technique lies in creating a free and open environment where members of the group participate without any inhibitions. It starts on the premise that when people interact in a free environment, the possibility for creative ideas to emerge to higher continuous interaction through free discussions may result in spontaneous and creative thinking. The larger are the number of solutions, the fairer are the chances in locating an acceptable solution. Established research proves that one hour brainstorming session is likely to generate 50-150 ideas. Of course most of them may be impracticable; at least, some of them merit serious consideration. This group process is

not without limitations. It consumes lot of time and therefore is an expensive exercise. Secondly, it emphasizes only quantity of solutions, which more often than not prove to be superficial. By overcoming the above limitations, a modern manager can use this as an effective tool.

2. **Synectics:** Synectics is a new concept developed by William J.J.Gordon. The term 'synectics' is derived from a Greek word which means "Fitting together of diverse elements". It starts on the premise of encouraging that this concept encourages novel thinking for the development of alternatives through putting together different ideas which are distinct from each other. A given problem is presented to a group of people with different backgrounds and varied experiences.

It is the responsibility of the group leader to present the problem and lead the discussion in order to stimulate creative solutions. This approach ensures on the spot evaluation of ideas. The leader who is a technical expert assists the group in evaluating the feasibility of their ideas. Experience shows that synectics is less widely used than *Brainstorming*. When the problem is tough and challenging, this approach is used for effective decision-making.

3. **Operations Research:** The origin and development of operations research is attributed to military operations and applications during Second World War. The war put tremendous pressure on the use of available scarce resources for various strategic and tactical operations. The success of operations research in developing effective options is instrumental in making this approach dependable in decision-making process. Operations Research employs optimizing models like Linear Programming, Project Management, Inventory Control, Decision Theory and Waiting Line Theory.

Operations Research is the systematic method of studying the basic structure, functions and relationships of an organisation as an open system. It aims at developing optimal solution with limited resources in a given situation.

The six steps in its approach to problem solving are:

- (a) identification of a problem;
- (b) construction of a mathematical model to investigate the problem;
- (c) developing a good solution;
- (d) testing of the model in the light of the data available;
- (e) identifying and setting up of control points;
- (f) implementation of the option as a solution to a critical problem  
(putting a solution to work)

In essence, Operations Research attempts to develop the best solution that will contribute to organisational goals.

### **Review Questions**

1. Define decision-making? Explain the basic characteristics of decision making process.
2. What are different types of decisions and explain their managerial implications.
3. Explain steps involved in the rational decision-making process.
4. “Absolute rationality in decision making is an illusion”. Critically examine the statement with examples.

\*\*\*



## Case Study

The day has finally come: Mr. Rajesh is to assume the position of President of Metro Manufacturing. Metro is a widely respected producer of high quality control mechanisms. When the previous president retired, Rajesh was identified as the likely choice for assuming the post. He was respected for his competence in the field and for his ability to work with employees at all levels of operations. Rajesh arrived at work early this morning, not so much to work but to think. As he sits behind his new executive desk, drinking a cup of coffee, his thoughts go back to his early days with Metro.

Twenty years ago Rajesh was just a young man right out of college with no business experience and a degree in industrial management. He was hired as an assistant foreman and was placed immediately on the production line. “Oh, those were the days”, he thought. “Seems like there was a problem that required solving every minute”. Thank goodness for the standard operating procedures manuals (SOP’s) and for a foreman who was patient enough to answer my questions, didn’t have to make too many critical decisions then. But I sure was putting out a lot of daily fires”.

As the nostalgia influence continues, Rajesh thinks back to the time when he was taken off the production line and promoted into middle management. “Things sure did change then”, he thought. As production manager, he had to think further into the future. As a foreman, Rajesh was primarily concerned with meeting daily production requirements. Now he had to plan weeks and even months in advance. The human and communication problems remained although it seems like the reports he had to write were longer. But, as he remembers, the major changes occurred because he had to do more creative thinking. Laughing to himself he thought about the time he went to the files to pull out on SOP for an unusual problem he had to confront and there was none. He was frustrated because he had to handle the problem with little assistance. But, as his analytical, decision-making, and conceptual ability increased, he found himself using his technical skills less and less.

Another cup of coffee provided the stimulus to think about the special promotion he made to vice-president of planning five year ago. It was a major hurdle in his life because he had been in heavy competition

with five well-qualified managers. He had heard through the grapevine that he had received the position because he was able to think for himself. But, even his past training did not fully prepare Rajesh for the demands of the job; he had to learn much of it on his own. Rather than thin months into the future, he now was required to envision years. Grinning, he remembered that at first he did not realize that there were so many people outside of production that he had to coordinate activities with. Marketing and finance had to be tied together with production. His conceptual and decision-making skills continued to increase. A long time ago, the benefits of the “good old” SOP’s lost their value.

But now, as Rajesh looks at his desk plate which says “President” new thoughts run through his mind. A whole new world opens to him now. He wonders what new requirements will be placed on him. A twinge of fear moves through his body as the thoughts of the new job take hold. What skills will be now needed to be successful?

### **Questions**

1. As the President of Metro Manufacturing, what specific skills will Rajesh need to be effective?
2. How do the demands of different levels of responsibility change as manager progresses up the hierarchy of an organisation?
3. What general recommendations would you offer for Rajesh?

\*\*\*

## UNIT - II

---

### Lesson - 9 : Organisation Structure And Design

---

#### Objectives

*After Reading this lesson, you should be able to:*

- Understand The Meaning Of Organizing;
- Describe The Steps In Organizing Process;
- Know The Process And Methods Of Departmentation; And
- Draw The Organization Chart Based On The Method Of Departmentation You Choose.

#### Lesson Outline

- Steps In Organizing Process
- Organisation Structure
- Chain Of Command
- Span Of Management
- Functional Departmentation
- Product Departmentation
- The Matrix Structure
- Review Questions

The managerial function organizing may be understood as “defining and grouping the activities of the enterprise and establishing authority, responsibility and relationships among them”. It results in the creation of a structure most appropriate for the organization’s objectives and other internal and external factors. The best structure is the one that enables the organization to interact effectively with its environment, to efficiently channelize the efforts of its people, to make efficient use of its resources. Thus, while planning specifies the objectives, organizing facilitates the accomplishment of objectives.

## **Steps in Organizing Process**

Organizing is a multi-step process consisting of the following:

- Detailing all the work that must be done to attain the objectives; (identification of tasks involved);
- Dividing the total work into activities that can logically and comfortably be performed by one person or by a group of persons; (differentiation);
- Grouping the related tasks in a logical manner (departmentation);
- Setting up a mechanism to coordinate the work of members into a unified whole by establishing authority – responsibility relationships, (delegation and decentralisation of authority); and
- Monitoring effectiveness of the organization and making adjustments to maintain or increase its effectiveness.

The various steps in organizing process results in a structure that facilitates the performance of tasks in a cohesive way. The resulting structure, however, is not a static form, like the structure of a building. Since structure is based on plans, major revision of plans may necessitate a corresponding modification of structure. As such, organizing and reorganizing are ongoing processes. Successful organizations continuously assess the appropriateness of their structure and change it in accordance with the dictates of the environment. It is anybody's knowledge that many Indian companies are restructuring their activities to meet the new challenges in the present liberalization era. Organization structures are modified periodically in response to the environmental demands. Management expert Tom Peters estimates that about 50 percent of organization problems arise from inappropriate organization structure. Because adaptation is a key to competitive survival, the 'right' structure for an organization is determined by numerous factors. For this reason, selecting an organization structure might best be described as an evolutionary, trial-and-error process.

## **Organization Chart**

Organization structure may be presented in the form of an organization chart that shows all the positions in an organization and their formal relationships to one another. It illustrates an organization's overall

shape and the levels of management in a comprehensible manner. The organization chart of a typical company structured on functional basis is presented in the following chart.

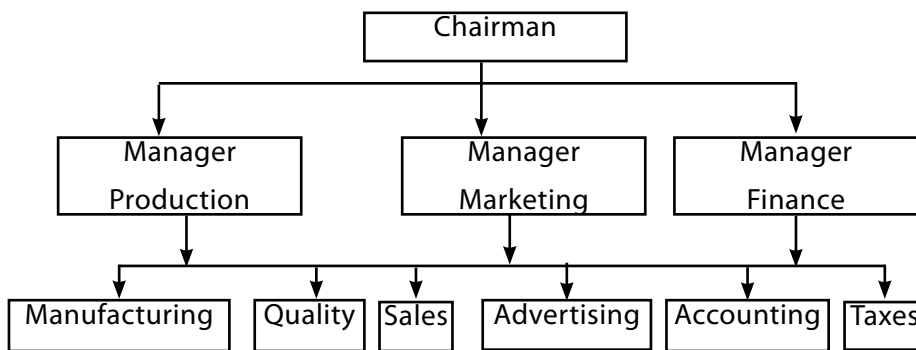

**Figure 9.1: Organisation Chart**

As could be seen in figure, an organization chart shows:

- The hierarchical structure that is typical of most organizations;
- The number of management levels;
- Scope of authority and status of the individuals as indicated by the location of their position in relation to other positions;
- How an organisation's activities are grouped in terms of departments (whether by function, by product, territory and so on);
- The work being done in each position (indicated by the labels in the boxes);
- Interaction of people as indicated by the horizontal and vertical lines connecting various positions/ departments;
- Relationships between superiors and subordinates in terms of who reports to whom, that is, the chain of command;
- How many subordinates report directly to each manager, that is the span of management;
- Career progression, and
- Formal channels of communication (indicated by the connecting lines).

However, an organization chart does not show:

- Interactions between people who have no official reporting relationships, that is, the informal organization;

- The ongoing dynamics of workplace behavior;
- Personal preferences and coalitions;
- Informal communication channels; and
- Interference by outsiders.

The organization chart of any company, therefore, enables one to understand easily three classical principles of organizing, viz., chain command, unity of command and span of control.

### **Chain of Command**

The type of arrangement of various positions in an orderly way is termed scalar chain or chain of command. The chain of command exists wherever an individual is made subordinate to another. Since ancient times, it has been recognized that the only way to structure unified systems involving large number of people is through a chain of command. The resulting hierarchy is found in every company or in any human system including a family. Following chart depicts the chain of command in a typical manufacturing company. In addition to defining different degrees of authority of people, Chain of Command also suggests the routes through which information flows within an organization.

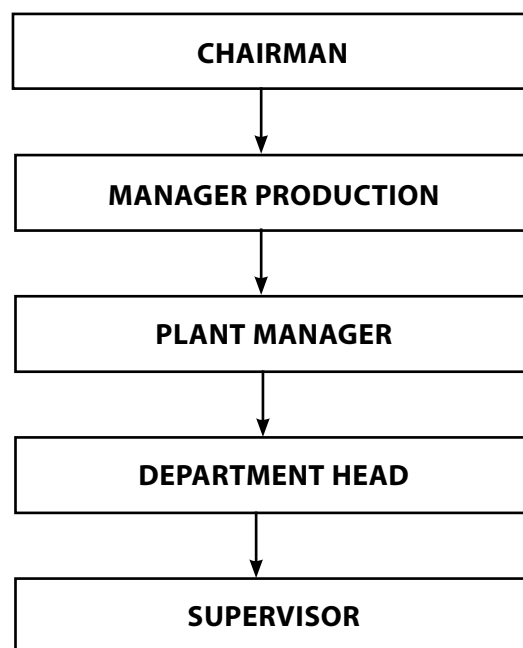

**Figure 9.2: Chain of Command**

## **Unity of Command**

The Chain of Command principle implies another feature of organizing: one subordinate-one boss. If the efforts of subordinates are to be effectively coordinated, it is necessary that they must have a reporting relationship with only one superior. Unity of command principle avoids the confusion as to who should report to whom and who should issue orders to whom.

## **Span of Management**

It is anybody's knowledge that a manager cannot effectively supervise the activities of an infinite number of subordinates. This is because of the limitations of time, energy and skills. These limitations place natural limit on the number of subordinates that a manager can effectively supervise. But for this limit, organizations would have not taken the pyramid shape. Span of management refers to the number of subordinates that report directly to a manager. The traditional thinking was that an effective span involved some definite number of subordinates. For example, Lyndall Urwick found "the ideal number of subordinates for all superior positions to be four and at the lower level of the organization, the number may be eight or twelve". Often, one of the first things done by an organizational analyst or consultant was to count the number of subordinates reporting to each manager. In each instance, when the number exceeded a definite figure, say – six or eight, there would be a recommendation to narrow the span. Thus, the thinking of the classical theorists about the span revolved around a definite number.

## **Classical Thinking on Span of Control**

As explained above, the traditional theory of management was much concerned with the specific number of subordinates that could be supervised by a manager. For instance, Lyndall Urwick suggests that no executive should attempt to supervise directly more than five. Different thinkers suggested different spans both at the top and lower levels of organization.

The contribution of V.A. Graicunas was however, significant to the span of management theory. According to him, in selecting a span

managers should consider not only the direct one-to-one relationship with their subordinates, but also two other kinds of relationships, namely, direct group relationships and cross-relationships. As such, if A has two subordinate B and C, the following relationships would emerge.

- i. **Direct one-to-one relationships:** These relationships relate the superior directly with his subordinates, A in this case will have two direct relationships with B and C, viz., A to B and A to C.
- ii. **Direct Group relationships:** This refers to the relationships of superior with the various possible combinations of subordinates. In the above example, A may interact with B in the presence of C or with C in the presence of B. Graicunas argues that though the individuals are same, the two situations have different implications.
- iii. **Cross – relationships:** This type of relationships is created when subordinates consult one another. In our example, the two cross relationships are B with C and C with B. Graicunas gave a formula to ascertain the number of all the three kinds of relationships:

$$\text{Number of Relationships, } n = \frac{2^n}{2} + 2 - 1$$

n stands for the number of subordinates. One can easily ascertain how the number of relationships increases as the number of subordinates rises by applying this formula.

With four subordinates, the total relationships go up to 44, with five subordinates to 100, with six subordinates to 222, and with 10 subordinates to 5,210. Though Graicunas formula explains the complexities involved as the number of subordinates increase, it suffers from the following inadequacies.

- The formula ignores the frequency and importance of relationships, and
- Several other factors which have a bearing on the superior subordinate relationships have not been taken into consideration.



## Span of Management and the Levels

The limitation on the part of a manager to manage an infinite number of subordinate obviously results in the levels in the organization. Thus, an inverse relationship generally exists between the span of management and number of management levels. That is, if an organization has wide span, the resulting structure will be flat, with few levels of management. Conversely, if an organization has narrow span; the structure will be tall with many management levels. Both the situations of wide as well as narrow spans and the resulting flat and tall structures are shown in Figure. Company B: Flat structure caused by wide spans of control for 64 operative employees.

(Span of control: 8, management layers: 2)

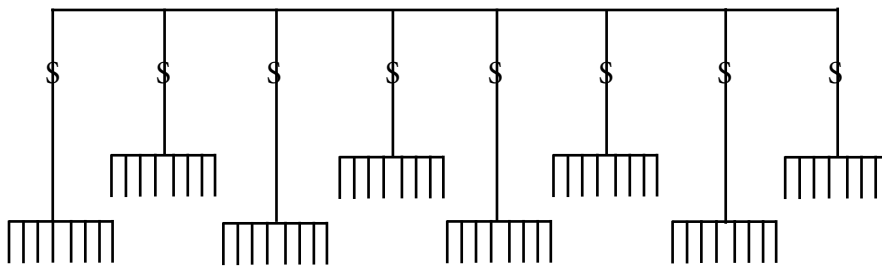

**Figure 9.3: Span of control and Management layers**

Company A: tall structure caused by narrow spans of control for 64 operative employees

(Spans of control: 4; management layers:3)

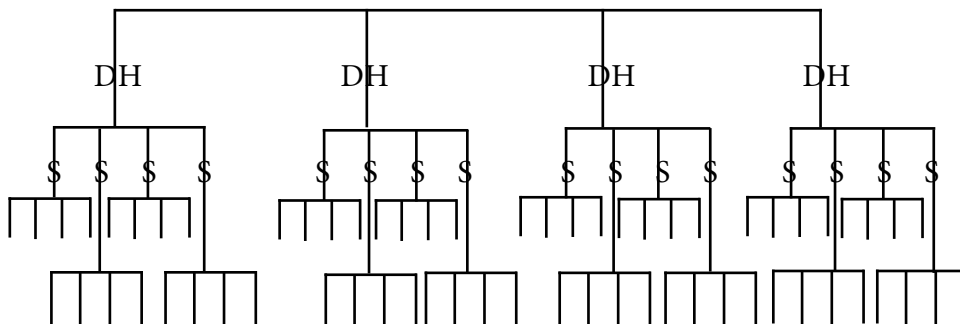

**Figure 9.4: Span of control and Management layers**

As presented in the above figures, in Company A, each supervisor's span covers four subordinates, and four department heads report to the chairman. There are a total of 21 managers, arranged in four management levels. In contrast, in company B, each of the eight supervisors exercise controls over eight subordinates. As a result, there exists only three layers. In this case, by increasing the span from four to eight, one layer of management is eliminated.

### **Problems with levels**

Creation of too many levels has certain problems related to the costs associated with communication and managerial control.

- i. **Costs:** Levels are costly. Too many levels involve lot of expenditure. Additional facilities in terms of secretarial staff have to be provided besides the pay differentials in the compensation package. In many organizations substantial expenditure has been saved by increasing the span.
- ii. **Communication:** Successive layers of management act as communication filters distorting the transmission of information. Experience shows that the greater the number of management levels a message must pass through, the longer it will take to reach its destination. More often, the information also loses clarity. Thus, communication or organizational objectives, plans and policies become difficult. Omissions and misinterpretations usually occur as information passes through too many levels in the scalar chain.
- iii. **Managerial control:** The distance between the top and bottom levels of an organization also affects control. For example, even the best of the plans which are definite and complete at the top level lose clarity as the plans are sub-divided and elaborated at lower levels. Consequently, at the implementation stage of the plan, control becomes difficult.

### **Current Thinking on Span of Management**

In contrast to the traditional thinking, modern management theories emphasize that there are too many variables that influence the span. Thus, the emphasis has shifted to the variables in the situation. While the fact that there is a limit to the number of subordinates that can

be effectively managed can not be disputed, the exact number will depend upon the following factors.

### **Factors Influencing Span of Management**

- i. **Manager's personality:** If managers share a strong need for power, they may prefer a wider span of control. On the other hand, some managers feel threatened because they cannot oversee the activities of too many people. Such managers would naturally prefer a narrow span.
- ii. **Manager's capability:** An experienced, well trained and knowledgeable manager is normally able to handle a relatively wider span than a less capable manager.
- iii. **Subordinates capabilities:** Experienced and well-trained subordinates will be able to resolve the difficulties themselves. They do not take much of the time of the superior. The need for frequent contacts is also obviously less.
- iv. **Fatigue tolerance:** Physical and mental fatigue may limit a manager's capacity for control. There are only so many hours in a day, and only so many things can be done at a time. Consequently, the greater the physical or mental demands of a job, the narrower the span of control.
- v. **Activity level:** The pace and pattern of work in an engineering firm, an investment firm, and a university differ in many respects. Moreover, there also exist differences between the various units of an organization. For example, production activity compared to public relations. Thus, the more active the pace and pattern of a manager's work, the narrower the appropriate span of control.
- vi. **Non-supervisory activities:** If a manager spends more time on non-supervisory activities like long-range planning and outside assignments, he tends to have less time to supervise the subordinates. This obviously limits the span.
- vii. **Similarity of activities supervised:** If the nature of activities performed by the subordinates is routine, the superior can manage many subordinates. On the other hand, if unique and non-routine problems are more frequent, the span is limited.
- viii. **Complexity of work:** Simple job assignments are usually easier to supervise than complex ones. The problems that arise are generally less demanding and take less of the superior's time. Thus, less

supervision will be necessary, contributing for a wider span.

- ix. **Availability of sophisticated facilities:** Availability of more advanced and sophisticated facilities like high speed telecommunication devices, modern office equipment, etc., will help the manager in managing a relatively wider span.
- x. **Location:** If subordinates are physically dispersed, a manager will need to spend more time in travelling and communicating. The span of control in such a case will be narrow. To conclude, it has to be remembered that despite the desirability of flat structures, the span of management may be limited by certain factors. As an enterprise grows, the increase in organization levels cannot be completely avoided. What is required is a precise balancing of all the factors in a given situation. Widening spans and reducing levels may be the answer in some cases, while the opposite may be true in others.

## **Departmentation**

Organizations are in different sizes and may be producing single product or multiple products. May be operating in small geographic area or different areas in the world. To cope with these varied objectives, strategies and situations, managers adopt different design/models of organization structure. Departmentation is the process of dividing the organization's overall task into manageable submits. The subunits are often referred to as departments, divisions, or sections. By whatever name the units are called, the process of creation of such sub-units to facilitate the performance of activities is known as *departmentation*.

## **Functional Departmentation**

This is perhaps the most logical and simple form of departmentation. Functional departmentation is the process of creating organizational units on the basis of the firm's major activities. It involves grouping employees according to the broad tasks they perform. Normally separate departments are created for all the key activities of the business. For example, in a manufacturing company, the activities essential to the existence of the company relate to production, marketing human resources and finance. However, in non-manufacturing concerns the primary activities may differ. In a transport company, the key areas may be operations, sales and finance. Thus, public utility concerns like electricity, transport, banking,

insurance and hospitals have their own distinct key functional areas. In all these cases, under functional departmentation, major or primary departments are created along the key functional areas of the respective business.

If the organization is large, or in other words, as the organization grows, major departments can be subdivided. These sub divisions or departments are called derivative departments. The essential idea is to take advantage of specialization. A typical functional organization with major departments and derivative departments is shown in figure.

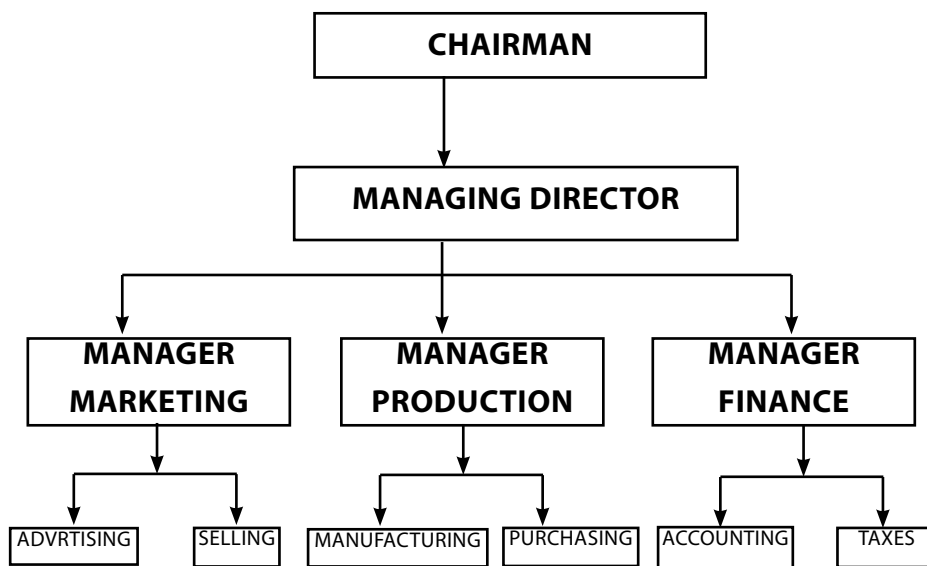

**Figure 9.5: FUNCTIONAL DEPARTMENTATION**

The following are the advantage and disadvantages of functional departmentation.

***Advantages:***

- It is the most logical and simple form of departmentation;
- It makes efficient use of specialized resources and skills;
- It makes supervision easier, since each manager has to be an expert in only his or her functional area of operation; and
- It fosters development of expertise in specialized areas.

### ***Disadvantages:***

- Functional departmentation is often found to be inadequate to meet the growing needs of the business, particularly as the organization expands or diversifies its activities;
- Further, decision-making becomes slow as the functional managers have to get the approval of the headquarters;
- It is also difficult to determine accountability in a functional structure. If a product fails, the question as to who is responsible cannot be easily answered; and
- Functional managers tend to develop narrow perspective and loose sight of the bigger picture. Members of each department feel isolated from those in other departments. For example, manufacturing department may be obsessed with cost reduction and meeting the delivery dates neglecting the quality control. As a result, marketing department may be flooded with complaints.

### **Product/ Market Departmentation**

As organizations are not static, they grow in size either by broadening its product line, or by expanding geographically. Further, as the size of the organization increases, some of the disadvantages become more apparent. The organization is rather forced to look for other models in tune with the requirements. In such situations, managements opt for various other types of departmentation, in order to have the right focus on the product or market or the process. Three patterns are adopted generally by organizations depending on the specific requirements to overcome the limitations of functional structure. They are product, territorial and customer departmentation.

#### **i. Product Departmentation**

One of the most common ways in which businesses grow is by expanding the product mix. If the organization is successful in expansion, several product lines may attain such high sales volume that each product category or line may be a separate division. Large organizations like Kirloskar, Hindustan Unilever, Godrej have managed such expansion of product lines effectively by creating separate departments or divisions for the various products. Under product departmentation, a single manager,

often referred to as the product manager, is delegated authority over all activities required to produce and market that product. The focus in the product departmentation, therefore, shifts on to the product and all the activities related to the production and marketing of the product. As against functions in the functional departmentation, basic products or services become the primary or major departments in the product departmentation as could be seen in the following figure.

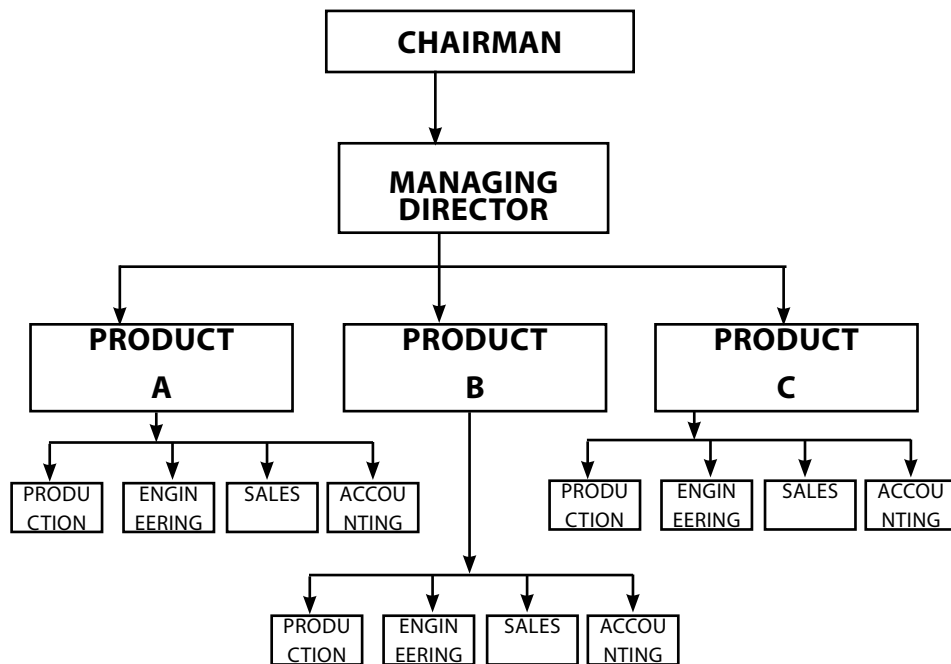

**Figure 9.6: Structure of Product Departmentation**

***Advantages:***

- Product departmentation places emphasis on the basic products, the success of which is critical to the survival of the organization;
- Since all revenues and costs are assigned to a particular product, cost centres can be established. High profit areas can be encouraged and low/unprofitable product lines can be dropped. Thus, responsibility for cost reduction and profits can be established at the division level;
- Proper coordination of all functional areas can be achieved as all the functional managers work as a team under close supervision of the product manager. Since the department or division is multifunctional, it often operates like an independent division or company within the large company;
- Enables quick-response to changes in environment as compared to functionally organized firm;

- Provide managers a training ground in general management which is useful in overcoming narrow functional perspective; and
- Expansion and diversification of business is made easy by creating new departments for the new products that are added to the existing business.

***Disadvantages:***

- Requires adequate availability of persons with general management abilities as more and more departments are created for the various products;
- The product departments may try to become too autonomous thereby making top management control difficult; and
- It is also common to find product departments engaged in the duplication of efforts. Each product unit has its own functional departments. These may not be sufficiently large to make maximum use of facilities. Thus product departmentation becomes an expensive organizational form, if adopted without proper justification in terms of the products strengths and market potential.

**ii. Customer Departmentation**

It is common that some organizations sell a wide variety of goods or services that appeal to different groups of customers, each of which has distinguished needs. Each customer group may have to be addressed differently. In such a case, departments may be created around customer groups. For instance, commercial banks organize their activities around customer groups to cater to their specific needs. As such, we find separate departments or divisions for agricultural, industrial and merchant banking operations. Similarly, we find an air-conditioning company like Blue Star organizing its business around domestic and industrial air-conditioning units.



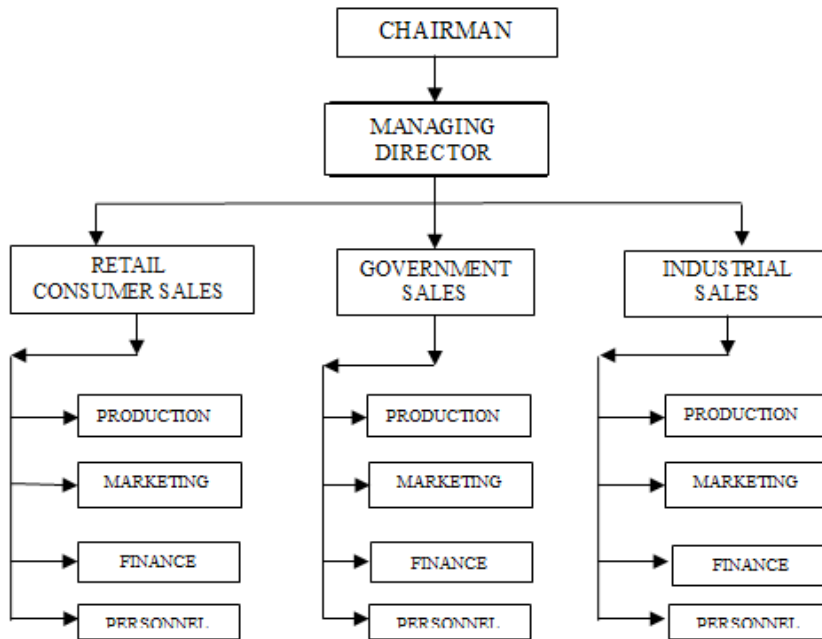

**Figure 9.7: Structure of Customer Departmentation**

***Advantages:***

- Customer departmentation facilitates concentration on customer needs. This is in line with the customer orientation professed by many organizations these days;
- Customers feel that they have an understanding supplier. For example, the manufacturer may sell to wholesalers and industrial buyers. Wholesaler requires a product of dependable quality with assured supplies. The industrial buyer wants products of high quality plus a service that includes installation and repair of the product and specific training of the company's employees; and
- Helps the organization to get the correct feel of the market dynamics in terms of preferences of the customers, degree of competition, competitors' strategies, etc.

***Disadvantages:***

- Difficult to coordinate operations between competing customer demands;
- Requires considerable expertise on the part of managers in understanding customers' problems and specific needs; and

- There is a possibility of under utilization of facilities and employees specialized in terms of customer groups. Small organizations particularly cannot afford the expenditure involved because some amount of duplication of the facilities is inevitable.

### iii. Territorial Department mentation

The process of creating departments along the geographical areas that the enterprise serves is termed territorial departmentation. This method is adopted when an organization operates in different geographical areas, each with distinct needs and dynamics. Territorial Departmentation makes it easier for the organization to cope with variations in laws, local customs and customer needs. Public utilities like transport companies, insurance companies, etc., adopt territorial departmentation. Similarly, a large scale organization operating both in domestic and international markets may have separate departments for both the markets. Again, different departments or divisions may be created for different regions of the world. Many multinational companies organize their global activities with regional headquarters in different regions of the world.

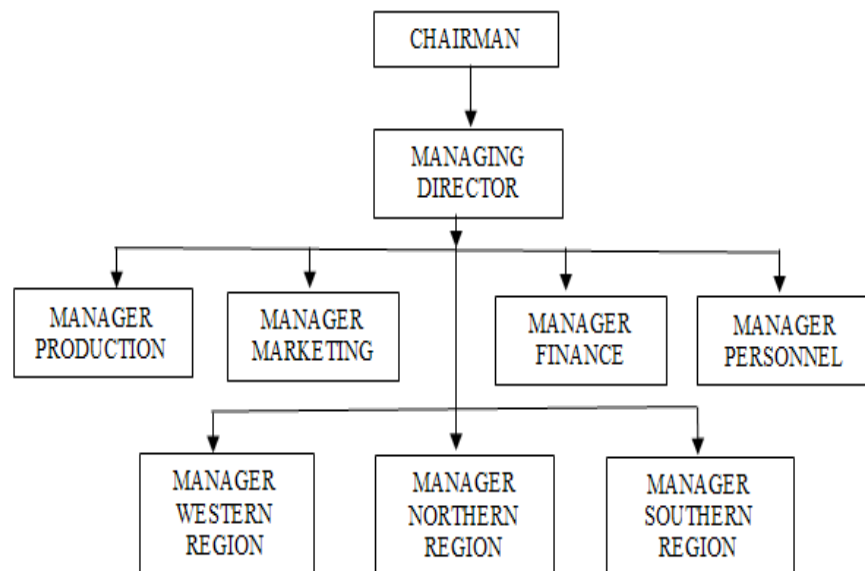

**Figure 9.8: Structure of Territorial Department mentation**

### ***Advantages:***

- Territorial departmentation makes it possible to concentrate on markets and marketing channels in different geographical areas;
- Develops opportunities for more efficient marketing activities because of better face-to-face communication with local stakeholders; and
- Makes possible effective utilization of locally available resources besides being able to cater to the region specific variations in terms of preferences and sentiments of the people.

### ***Disadvantages:***

- In this type of departmentation, there are problems in training people to think in terms of markets rather than products;
- Requires more persons with general management abilities; and
- Increases problem of top management control because of the distance between the corporate headquarters and the regional officers.

The three patterns of departmentation discussed above – product, customer and territorial departmentation broadly characterize the divisional structure. All the three patterns have advantages and disadvantages. The choice of any of these structures, therefore, would be based on which of the factors management judges to be more important and critical in the light of the strategies and objectives.

## **Project Organization**

The use of the project form organization has increased in the last few years. It is currently being employed in numerous undertakings engaged in the execution of construction activities, turnkey projects and research and development projects. The project organization can take various forms, but the important characteristic that distinguishes it from other forms is: once the project is completed the organization is disbanded or phased out. By definition, project management involves, ***“the gathering of the best available talent to accomplish a specific and complex undertaking within time, cost and quality parameters, followed by the disbanding of the team upon completion of the undertakings”***. The group members then go on to another project, return to their permanent home department in the organization, are given jobs elsewhere in the organization, or, in some cases, phased entirely out of the firm.

## The Matrix Structure

The matrix structure is a hybrid organization form, containing of characteristics of both project and functional structures. In consumer goods industries, it could contain the characteristics of both product and functional departments. This structure allows operational responsibilities to be divided into two parts. One part contains all the responsibilities associated with the management of an independent business and it's given to an individual who is called "business manager" or "product manger". The other part contains all the responsibilities related to the management of resources needed to get the job done. The person responsible for these is the "functional manager" or "resource manager" in charge of the functions like production, marketing, finance, personnel and so on. The matrix is built around a cooperative relationship between the project/ product manager and the functional/ resource manager. Thus, project staff members in a matrix structure have a dual responsibility. First, they are responsible to the head of their line superior and will continue to be so. But the project manager exercises what is called project authority over the project staff. Figure presents these dual responsibilities in a matrix form of organization.

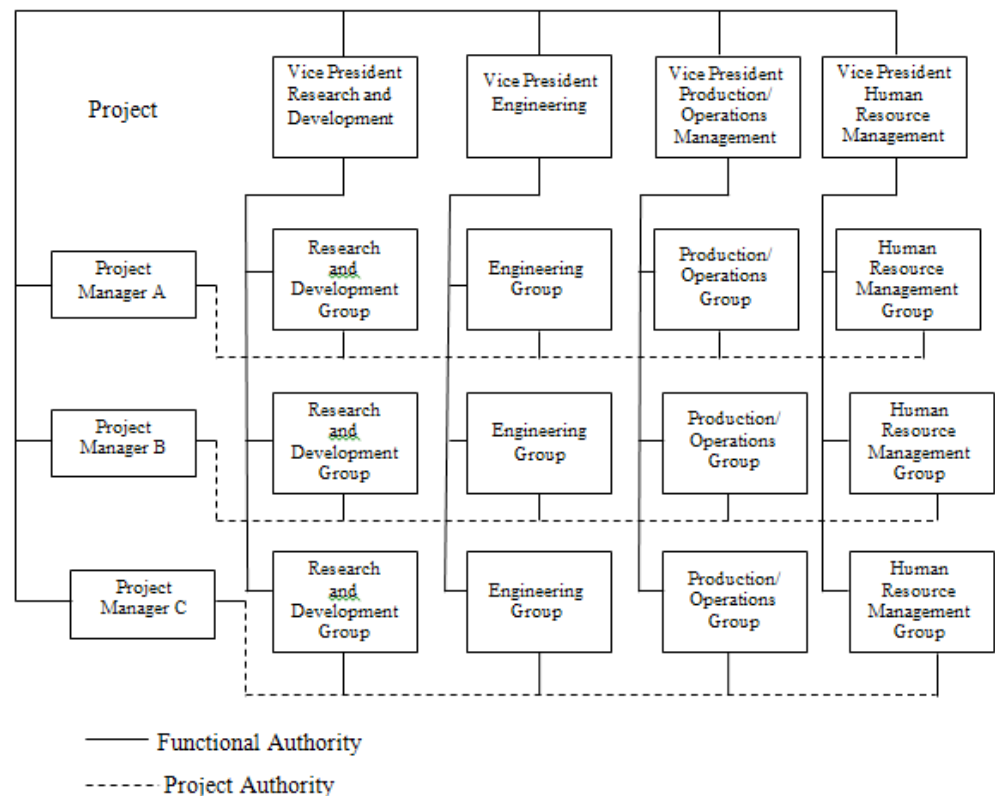

Figure 2.9: Matrix Structure

When the concepts of functional and project authority are brought together, the result is an organization structure that is both vertical and horizontal. The vertical pattern is brought about by the typical line authority flowing down from superior to subordinate. The horizontal authority flow runs through both the scalar principle.

Companies like Larsen & Tourbro (L&T), U.P. Construction Corporation, Afcons-Pauling, etc., adopt this structure for the execution of various projects. For instance, L&T's construction of Jawaharlal Football Stadium in Chennai and Afcons-Pauling's laying the East Coast Road are big projects themselves. The execution of such projects is entrusted to a team drawn from the functional departments of the headquarters. The overall responsibility for the project lies with project manager. The people who work in the project are responsible to the project manager as well as their functional head from whom they are drawn. The matrix may be temporary or permanent. In construction and turnkey activities, project is disbanded after the execution, whereas it may take a permanent form in the case of consumer goods company.

***Advantages of Matrix Organization:***

- Specialized knowledge is available to all projects or products on an equal basis. Knowledge and experience can be transferred from one project to another;
- Utilization of manpower can be flexible because a reservoir of specialists is maintained in functional departments. These specialists can be deployed to the various projects for optimum use of their services;
- Responsibility for the overall execution, management, and profit is with the project manager who acts like a chief executive;
- Project people have a functional home when they are no longer needed on a given projects; and
- A better balance between time, cost and performance can be obtained through the built-in checks and balances and the continuous negotiations carried on between the project and the functional organization.

### ***Disadvantages:***

In spite of its advantages, matrix structure suffers from some disadvantages. Managers have to learn to deal effectively with them.

- If the organization has too many projects, the result may be severe layering of matrixes. Uncontrolled growth of matrix structures often results in power struggles between managers;
- The major disadvantage relates to power struggles. Since use of the matrix means use of dual command, managers often end up in conflicts;
- Matrix entails wide use of group decision making because group cooperation is required for success. The inevitability of group cooperation at times delays decision making; and
- Matrix structure may be expensive. The dual chain of command may cause management costs to double.

Despite the drawbacks, matrix structure is preferred by many organizations because of the overriding advantages. In addition to construction and engineering, consumer goods, banking, insurance and computer companies are now using it. Variations of matrix are also used by hospitals and other professional organizations.

### **Contingency Organization Design**

In contrast to the models discussed so far, several contingency systems of late have come into wider practice. The emphasis in these systems is on flexibility. Accordingly, so many flexible structures are adopted these days to meet the specific needs of the organizations. This approach basically led to the development of a contingency theory of organization. The approach is based on the exigencies of the situation. William F. Glueck, offers the following guidelines for contingency design:

- When low cost and efficiency are the keys to successful goal achievement, organizations should use functional departmentation;
- When the environment is complex, matrix structure is effective;
- If the organization is large and operates in a stable environment, it can afford a more formal or rigid structure;
- The greater the intensity of competition, the greater will be the degree of decentralization;
- The greater the volatility of the environment, the more decentralized

and flexible the organization has to be; and

- Companies that adopt the organizational structure appropriate to their strategy will be more effective than those that use an inappropriate style.

### **Review Questions**

1. Drawing upon your personal experience as a student of management, give a few examples of chain of command.
2. "Organization chart provides a broad picture of positions of authority and their relationships in the organization structure". Examine this statement.
3. What do you understand by levels in the organization? Examine the implications of too few and too many levels.
4. What do you mean by span of control? Examine the traditional as well as modern view points on the span of control.
5. What are the basic characteristics of functional departmentation? Analyze its merits and demerits.
6. Suggest a method of departmentation for a large multi-product organization with a huge market spread over the whole country. Explain the reasons for your suggestions.
7. Under what conditions Territorial departmentation is preferred. Examine its advantages and disadvantages.
8. Explain the statement: "A matrix structure is a hybrid form of organization, containing characteristics of both product and functional structure".
9. Do you agree with the view that there is no one best way of departmentation applicable to all organizations? Substantiate your answer and explain what factors influence departmentation.

\*\*\*





---

## Lesson -10: Delegation Of Authority And Decentralization

---

### Objectives

*After reading this lesson, you should be able to:*

- Understand The Process Of Delegation;
- Know The Barriers For Delegation;
- Learn The Techniques To Overcome The Barriers; And
- Appreciate The Need For Decentralization Of Authority.

### Lesson Outline

- Process Of Delegation
- Barriers To Effective Delegation
- Overcoming The Barriers
- Decentralization Of Authority
- Factors Influencing Decentralization
- Review Questions

Delegation is the process by which authority is granted to a subordinate by his superior. But for delegation of authority, organizations would remain for ever small. Delegation is the only solution to cope with the increasing work load of managers as the organization grows. Because of the constraints of time and ability, a manager cannot perform all the tasks himself. Therefore, he delegates certain of the tasks to the subordinate and gets them done. Before proceeding further to understand the process of delegation, it is appropriate to examine, in brief, the concepts of authority and responsibility.

**Authority** is the right to command. It is the discretion power vested with a manager to use the organizational resources. Managers acquire authority by virtue of the rank or title associated with their position. Authority is granted to the individuals in a formal way in the organization. It flows from the top to down in the organization structure.

**Responsibility**, on the other hand is the obligation to perform the tasks and accounts for their satisfactory completion. It is implied that an individual is expected to fulfill certain job requirements when he or she accepts a position in the organization. In other words, the individual is answerable for the results of the task to be performed. In contrast to authority, responsibility of an individual in the organization is always upwards, that is, the subordinate is responsible to his or her superior.

## **Process of Delegation**

### **Entrustment of Duties or assignment of Responsibilities**

This is a crucial step in that a few important questions like what to delegate? When to delegate? Whom to delegate? And how to delegate are answered. The effectiveness of delegation depends on how clearly these questions are answered. First of all, the manager has to decide the tasks to be delegated to the subordinates. For this, he must be able to distinguish between the routine and non-routine tasks. Routine and simple tasks can as well be performed by the subordinates while the non-routine and very important tasks must be performed by himself.

### **Granting of Authority**

When the subordinates are assigned certain tasks or responsibilities, it goes without saying that they need authority also to perform the tasks. Authority is required by them to use the resources of the organization for the execution of the tasks. The superior, therefore, parts with his authority to enable the subordinates to perform. Responsibility and authority both go together. One of the important principles of organizing is parity of authority and responsibility which emphasizes the need for a proper balance between the two.

### **Creation of Accountability**

Delegation does not end with just entrustment of duties and the granting of authority. The superior has to create an obligation on the part of the subordinate to perform. In other words, the subordinate is accountable to his superior for the tasks delegated. Thus, while authority flows downwards, responsibility flows upwards. Normally, accountability

is created by asking the subordinates to submit performance reports/ status reports from time to time.

### **Barriers to Effective Delegation**

To make delegation effective, the spirit and willingness of both the parties are crucial. Though delegation is a powerful tool to motivate the subordinates and to develop managerial skills in them, if adequate care is not exercised the result may be considerable anxiety for both superiors and subordinates. Following are some of the reasons why delegation often fails in organizations to which both superiors and subordinates are responsible.

- i. ***Lack of Confidence in Subordinates:*** Lack of trust and confidence on subordinates' abilities and skills make the superiors reluctant to delegate. As a result, subordinates lose initiative and frequently seek the guidance of the bosses to know whether they are doing the things correctly.
- ii. ***The "I can do it better myself fallacy":*** Some managers always suffer from a feeling that they only can do the job better. Consequently two things happen. First, spending time on a task a subordinate could perform and as a result the manager may not be able to perform other important tasks like policy formulation and supervision. Second, unless the manager allows subordinates to attempt new tasks, the subordinates will be unable to develop their skills. Thus by insisting on doing things themselves managers often fail in their responsibility for training and grooming subordinates higher levels responsibilities.
- iii. ***Lack of ability to direct:*** Some managers become so involved in day-to-day operations that they ignore to see the broader picture. Unable to understand the long term perspective of the work flow, they do not fully realize the importance of distributing work among subordinates. Some managers deliberately do this because of lack of confidence in their supervisory abilities.
- iv. ***Aversion to Risk:*** Since the superior can not absolve himself of the final performance of the task, he may fear that delegating the job

will cause problems. Further, those superiors who see a threat in the subordinates always try to avoid delegation. This is mostly due to the mindset where superior fears that he may be outsmarted by the subordinate and eventually the latter may become a potential threat to this position.

- v. ***Absence of Selective Controls:*** When certain duties are delegated to subordinates, the superior has to ensure proper controls in the form of feedback about performance. It gives the superior the opportunity of knowing the problem before much damage takes place. If controls are not adequate and effective, manager has good reason to avoid authority delegation.
  
- vi. ***Inadequate Information and Resources:*** The subordinate lacks the information and resources needed to do the job successfully. Some managers with a view to let down their subordinates may deliberately make the delegation unclear. As a result the subordinate lands himself in confusion as to the exact nature of the duties and the authority that he can exercise. The motive of the superior in such cases may be to make the subordinate fail in the execution.

### **Overcoming the Barriers**

Several of the barriers to delegation discussed above mostly relate to the behavioral aspects of individuals. Insecurity, aversion to risk, lack of self confidence, inability to trust another to perform a task are all different types of manifestations of human behavior. Among the various barriers, psychological barriers are the most difficult ones to overcome. In order to overcome many of these barriers, both superiors and subordinates must take a hard look at themselves, recognize their own fears and try to come out of the inhibitions. The following measures may help delegation to be effective:

1. **Effective Communication:** When a subordinate does not perform the tasks as expected by management, the problem can be faulty communication. In the hurry to get the things done, managers may skip through what they exactly expect from the subordinate. The subordinate may also hesitate to ask questions for looking stupid. At times, subordinate too, may be in a hurry to get on with the job.

Consequently, both the parties may think they understand what was assigned and expected. Later, often too late, the work is not done right and both are disappointed. Thus, effective communication to subordinates of their responsibilities, tasks, and authority reduces the chances of misunderstandings between the two and thus paves the way for fruitful accomplishment of the tasks.

2. **Parity of Authority and Responsibility:** For delegation to be effective, it is necessary for authority and responsibility to be commensurating, that is, superior must delegate sufficient authority for the subordinate in order to enable him to accomplish the task for which he has assumed responsibility. For example, a marketing manager who got the task of increasing sales can accomplish the task, only when he is given authority to conduct an advertising campaign and provide motivational incentives to sales people. Absence of such an authority to use the organizational resources lands him in frustration. Imagine yourself for a while in the situation of having responsibility for the tasks without sufficient authority. In such a case you would let the superior know as soon as possible the actual situation and get the situation corrected.
  
3. **Incentives for additional responsibility:** Additional responsibility usually means additional work. An individual in any system expects to be rewarded for the additional responsibilities. But unfortunately, many organizations fail to offer positive rewards. Current research strongly indicates that employees will not be fully motivated if they feel they are giving the organization more than what they are getting. The rewards may be in many forms. Additional pay, promotional opportunity, a better job title, praise, added status, more pleasant working conditions, etc.

Though delegation broadly involves assignment of duties and granting of necessary authority to subordinates the actual practices vary. Having understood the concept of delegation of authority, the Dos and Don'ts, it is appropriate to take a look at the different degrees of delegation. Harvey Sherman categorized the following six degrees of delegation:

- i. Take action – no further contact with me is needed.
- ii. Take action – let me know that you did

- iii. Look into this problem – Let me know what you intend to do; do it unless tell you not to.
- iv. Look into this problem – Let me know what you intend to do; delay action until I give approval.
- v. Look into this problem – Let me know alternative actions available with pros and cons and recommend one for my approval
- vi. Look into this problem – give me all facts; I will decide what to do.

### **Decentralization of Authority**

The terms '*delegation*' and '*decentralization*' are often confused. While in delegation, authority is transferred on one-to-one basis from the superior to the subordinate, decentralization of authority is broader in scope and involves the transfer of authority in the organization context from top to the lower rungs of management in the hierarchy. Thus, the greater the amount of authority delegated throughout the organization, the more decentralized the organization is. Decentralization is much wider in scope reflecting management's philosophy regarding which decisions to be taken at the top as well as down the line in the organization.

It must also be understood that both absolute centralization and absolute decentralization are undesirable, for, the former refers an autocratic structure/approach while the latter results in a chaotic situation. For this reason, decentralization must be viewed as a relative concept and not as an absolute one. Ernest Dale, a well-known management writer, has described the following conditions where decentralization is greater:

- The greater the number of decisions made lower down the management hierarchy;
- The more important the decisions made lower down the management hierarchy. For example, the greater the sum of capital expenditure that can be approved by the plant manager without consulting anyone else, the greater the degree of decentralization in this field;
- The more functions affected by decisions made at lower levels. Thus, companies which permit only operational decisions to be made at branch/ plant levels are less decentralized than those which permit financial and personnel decisions at branch/ plant level;
- The less checking required on the decision. Decentralization is greatest when no checks at all are made; less when superiors have

to be informed of the decision after it has been made, still less if superiors have to be consulted before the decision is made. The fewer the people to be consulted, and the lower they are on the management hierarchy, the greater the degree of decentralization.

Decentralization results in unburdening of top manager, better decisions because decisions are made closer to the scene of action, better training, morale and initiative at lower levels. More flexibility and faster decision making are some of the advantages of decentralization. These advantages are widely acclaimed so much so that decentralization is often regarded as '*good*' and centralization as '*bad*'. But total decentralization, as mentioned earlier with no coordination from the top would be undesirable. That is why, the question before a manager is not whether an organization should be decentralized, but to what extent it should be decentralized.

However, the degree of decentralization in an organization will vary with time and circumstances. It will also vary for the different units of the organization. For example, production and sales department, in general, have gained a high degree of decentralization in many organizations, whereas financial related functions have tended to remain relatively centralized.

### **Factors Influencing Decentralization**

1. **Philosophy of Top Management:** The leadership style, attitudes, values and beliefs of the top management team have a bearing on the degree of decentralization. Some firms are highly centralized, whereas others are highly decentralized because of the character and philosophy of the top management. For instance, if Tata Group Companies have registered a phenomenal growth over the years, it is partly because of the operational freedom and autonomy the various units in the group enjoy. TATAs provide only the direction and spell out the major policies.
2. **Attitude of Subordinate Managers:** The Attitude of subordinate managers is another important factor that influences decentralization because they can both encourage or discourage decentralization. If subordinates want decentralization, top management can not hold every thing in their hands for too long a period. The desire

by subordinates for independence and the willingness to assume increased responsibilities may make them think of decentralization. As against this, shortage of lower level managers who are willing to assume responsibility may encourage top management to maintain a centralized structure.

Now-a-days, in most large-scale organization, the trend is towards decentralization. This is in line with greater employee empowerment. Pushing authority down the line to lower levels in an organization results in an environment of freedom and experimentation. Employee empowerment helps in fostering an entrepreneurial spirit in the organization, by encouraging employees at lower levels to accept responsibility, to unleash their full potential, and most important, to think and innovate. The benefits of decentralization are clear. However, the extent of decentralization depends on the unique requirements of an organization. It normally varies from organization to organization.

3. **The cost and Impact of the Decisions:** Managers may not be willing for decentralization where the commitment involved in the decisions is very high. As a rule of thumb, the greater the cost involved, the more likely it is that the decision will be made at the upper levels. We often find situation in organizations where managers seek the approval of superiors when the expenditure involved exceeds a certain limit.
4. **Company Size and Rate of Growth:** It is very difficult to manage a large organization efficiently with decision-making authority concentrated in one or few people/levels at the top. Further, as an organization grows in size and complexity, the need for decentralization is obviously felt. Top management cannot continue to hold a tight grip over the several aspects of the growing organization. This is the principal reason why organizations often engage in reorganizing their units and operations as they grow in size. The necessary autonomy is given to the units or departments so that top management can concentrate itself with more important tasks such as strategic planning and policy formulation.



## **Review Questions**

1. Explain the process of Delegation
2. In spite of its importance, why delegation fails in organizations.
3. What measures do you suggest to make delegation effective?
4. Distinguish between Delegation and Decentralization of authority.
5. Examine the factors that influence decentralization.

\*\*\*



---

## Lesson - 11: Line And Staff Relationships

---

### Objectives

*After studying this lesson, you should be able to:*

- ▶ Understand The Concept Of Line And Staff;
- ▶ Identify The Reasons For The Conflicts Between Line And Staff Managers; And
- ▶ Suggest Ways And Means To Achieve Proper Harmony Between The Two.

### Lesson Outline

- ▶ Line And Staff Concepts
- ▶ Line And Staff Conflict
- ▶ Harmony Between Line And Staff
- ▶ Review Questions

Line and Staff concepts denote the nature of authority - responsibility relationships among people working in organizations. Though the concepts have been present in management literature for many years, they still remain to be clouded with conflict and confusion. The view points of different authors widely differ in regard to the line and staff relationships.

### Line and Staff Concepts

Koontz and Weirich have defined line and staff authority as follows:  
*“Line authority becomes apparent from the scalar principle as the relationship in which superior exercises direct supervision over a subordinate an authority relationship in direct line or steps. The nature of staff relationship is advisory. The function of people in a pure staff capacity is to investigate, research, and give advice to line managers to whom they report”.*

There are two approaches to understand line and staff concepts. One approach lays emphasis on the basic functions of the business.

Accordingly, functions of an enterprise are classified into line and staff functions. To quote Louis Allen: “Line functions are those which have direct responsibility for accomplishing the primary objectives of the enterprise and staff functions refer to those elements of the organization that help the line to work most effectively in accomplishing the primary objectives of the enterprise”.

According to this approach, organizational objectives are the basic determinants of line and staff functions and with the change in the objectives, line and staff functions may change. A line function in one organization may be a staff function in another. For example, personnel function in an employment agency is line but it is a staff function in a manufacturing organization. In a manufacturing organization whose basic objective is to produce and sell goods, production and marketing are line functions and others such as public relations, personnel, legal, etc., are staff functions. Further, within a department, there many are line and staff functions, for example, in marketing department, selling may be a line function whereas market research is a staff function.

The other approach views that line and staff are two kinds of authority. According to this approach, line authority is defined as a direct authority which a superior exercises over his subordinates to carry out orders and instructions. The exercise of this authority is always downwards, that is, from a superior to a subordinate. Staff authority involves giving advice to line managers to carry on the operation. The flow of this authority may be in any direction depending on the need for such an advice. It is common that in actual practice some variations may exist. The variations are more pronounced in the case of staff authority.

The distinction between line and staff though not rigid, is important because staff must be provided if the growing organization is to accomplish its goals. The differentiation is necessary for the following reasons.

### **Line Authority**

In the organization process, authority is delegated to the individuals to perform the activities. These individuals, in turn, assign some of the activities to persons working below them in the hierarchy and delegate them authority. This process goes on, creating superior – subordinate

relationships in the organization. The direct relationship between a superior and his subordinate is created through the enforcement of line relationship. Such a relationship works as follows:

### **As a Chain of Command**

A command relationship exists between each superior and subordinate. Line authority is the heart of this relationship because it empowers a superior to direct the work of his subordinate.

### **As a Channel of Communication**

Line authority can be treated as a channel of communication between the members of the organization. Communication up and down in the organization flows through the line relationship. Barnard has emphasized the role of line relationship as a channel of communication by suggesting that every member of the organization should be tied into the system of communication by having someone to report to and others to report him. Such a line can be maintained easily through the channel of command.

### **As a Carrier of Responsibility**

The line relationship carries ultimate responsibility for the work assigned. Though the process of assigning activities goes on till the level where actual task is performed by operatives, each individual in the line is accountable for the proper performance of the activities assigned to him.

### **Staff Authority**

The relation between a staff manager and the line manager largely depend on the type of duties performed. A man who only gathers facts or only checks on performance will have relationship with line manager that are different from those of a man who has concurring authority. Such variations between line and staff relationships as discussed earlier, run along a continuum with only advice at one extreme point and functional authority at other extreme point. In between, two more situations represent compulsory staff consultation and concurring authority. Thus, variations are often found in respect of staff authority and responsibility in

organizations. The different shades of staff authority are discussed below:

### **Advisory Staff Authority**

This is the type of staff relationship popularly associated with the term staff authority. An advisory staff manager provides advice, assistance, and information and it depends on the line manager whether these are put into action or not. Thus, a staff relies largely on persuasion to get his ideas put into effect. In the absence of power of command, he must build confidence in his opinions. Therefore, a staff manager has to depend on his persuasive skills.

### **Compulsory Staff Consultation**

Some organizations prescribe the practice of compulsory staff consultation. Under this arrangement, a staff man must be consulted before action is taken. However, line manager is free to take action of his choice after consulting staff. Compulsory consultation supplements a more general requirement for successful staff work- the requirement that a staff should have access to any information that relates to his field of interest.

### **Concurring Authority**

At times, a staff man may be granted authority so that no action can be taken until he agrees to it. For example, quality control inspector must pass on raw materials or semi finished products before they move to the next stage of production, or agreement with employees over the matter of wages should be entered only after the personnel manager has agreed to it. The idea of concurring authority is that the staff view point is incorporated into operating decisions. These considerations suggest that concurring authority is granted only when the viewpoint represented by a staff man is particularly important when possible delay in action will not be serious. For example, it may be prescribed that a finance manager can not withhold capital expenditure simply because of his disapproval of capital expenditure plan, but he can withhold it when funds are not available or funds can not be arranged. In government organizations, normally wide-ranging concurring authority is granted to staff men.

## Line and Staff Conflict

Line and staff relationship implies that both are complimentary in nature. However, there are frequent instances of conflict between line and staff in the organizations, resulting in friction. The various factors leading to line-staff conflict can be grouped into three categories: apprehensions of line managers, apprehensions of staff, and nature of line-staff relationship. Let us examine how these apprehensions generate conflict.

### Apprehensions of Line Managers:

Line managers who are responsible for the final results leading to the achievement of organizational objectives, often criticize the staff managers on the following grounds:

- i. **Encroachment of Line Authority:** Line managers often see a threat to their authority in the staff. They perceive that staff people encroach upon their authority by advising on matters which fall within their jurisdiction. Whenever there is such encroachment the result is resentment, hostility, and open or hidden reluctance to accept advice and recommendation.
- ii. **Dilution of Authority:** Closely related to the earlier one is a feeling that staff people dilute line authority. Line managers fear that their responsibility will be reduced because of the addition of staff thereby making their job less challenging. Such a feeling of insecurity makes line managers suspicious of staff managers.
- iii. **Lack of Responsibility:** The disparity between authority and responsibility and also between contributions and rewards is a source of jealousy between line and staff. Line managers often allege that staff people are not directly accountable for the results, but enjoy authority. Lack of responsibility makes them complacent and they do not care for the ultimate objectives of the organization. Further, line managers contend that they will be criticized if things go wrong, while the staff will get the rewards if things go well.
- iv. **Theoretical Bias:** Often the advice and recommendation of staff people suffer from theoretical bias because of two reasons, *First*, they

tend to think within the context of their own specialty, *Second*, as staff people are away from the actual operational scene, they are not able to fully appreciate the actual dimensions of the problems and their recommendations may not be practicable.

### **Apprehensions of Staff Managers**

Staff managers also have their share of grievances against line managers. They find fault with line managers on the following grounds:

- i. ***Resistance to New ideas:*** Staff managers at times may come out with new and novel ideas. Line managers often resist such ideas because new ideas mean that there is something wrong with their present way of working. Thus new ideas are treated as fault-finding devices in their operation. Because line people are reluctant to new ideas, many of the efforts of staff people go waste.
- ii. ***Lack of Proper Use of Staff:*** Staff people content that line managers do not make proper use of their services and decisions are made without inputs from staff. They are informed after the action has been taken. By virtue of his position, a line manager can accept, amend, or reject the advice of staff irrespective of its quality and practicability. Further, when something goes wrong, staff person from concerned field is made the scapegoat.
- iii. ***Lack of Proper Authority:*** Staff people feel that they contribute substantially to organizational objectives, at times with no authority whatsoever. Line managers clearly hold most of the cards and enjoy enormous authority. In many cases, consultation of staff is only optional. As a result, staff specialists feel that if they have the best solution to a problem, they should have authority over line managers to force the solution.

### **Nature of Line-Staff Relationship**

In addition to the factors discussed so far, following inherent characteristics of line and staff relationship also contribute to conflicts and tensions.



- i. **Lack of demarcation between line and staff:** The differences between line and staff authority seem to be clear in theory only. In practice, they are neither clearly understood nor practiced. There is always a possibility for overlap and gap in authority and responsibility which can affect personal relationships.
- ii. **Divergent Backgrounds:** Line and staff-people significantly vary in respect of backgrounds and individual characteristics. Staff people are generally younger, better educated, more poised in social interaction, more articulate and individualistic. As a result, they often look down on the less educated line people who must have worked their way up through the organization. These differences create an atmosphere of mistrust and hatred between them.

### **Achieving Harmony between Line and Staff**

The effectiveness of line people depends to a large extent on how they make use of staff. Staff people are needed in the organizations because line people may not be able to solve the problems which require specialized knowledge. For making proper use of staff, following points are important:

- i. Staff people should be involved right from the initial stages of planning of an activity rather than when the problem becomes critical. When they are involved at the level of planning, many of the problems may not arise.
- ii. In order to make proper use of staff, they should not be kept busy in unimportant work because it does not serve any meaningful purpose. Instead, they should be assigned critical work in the area of their specialty.
- iii. There should be encouragement and education to line people as to how to make maximum use of staff effectively. Line people can not make use of staff unless they know what a specialist can do for them. At the same time, staff people also have a responsibility to let line people know how they can contribute for the better performance of line activities.
- iv. If line people take some actions directly affecting staff activities without consulting staff people, they should be informed immediately

about such actions. The information will help in removing misunderstandings, if any, created in the minds of staff people.

**Review Questions:**

1. Critically examine the line and staff authority concepts with the help of a few examples.
2. Line-staff conflict occurs for many reasons. Examine the following adages; “staff should be on tap, not tap”, and “staff should sell, not tell”.
3. Describe the difference between the advisory authority, concurrent authority and functional authority.
4. What are the important sources of conflict between line and staff managers? How do you resolve the conflicts?

\*\*\*

---

## Lesson - 12 : Emerging Trends In Corporate Structure

---

### Objectives

*After reading this lesson, you should be able to:*

- ▶ Understand The Influence Of Strategy And Culture On The Design Of Organization Structure;
- ▶ Capture The Impact Of Technology On The Organization Structure; And
- ▶ Know The Differences Between Mechanistic And Organic Structures.

### Lesson outline

- ▶ Organization Design In Future
- ▶ Strategy And Organization Design
- ▶ Impact Of Environment On Design
- ▶ Mechanistic Vs. Organic Structure
- ▶ Review Questions

For many years the fundamental structure underlying organization design has been the classic pyramid. Although it still plays a major role, some authors suggest that organization design in the future will be characterized by four basic differences from today's pyramid-oriented structures and will exhibit:

- *A less number of management levels*
- *Adhocracy and porous departments*
- *Systems decoupled from the structure*
- *The sharing of resources rather than the dividing them*

## **Organization Design in the Future**

### **Less Number of Management Levels**

The distance between the point where an organization experiences the forces of change-especially in its markets, technologies, and products and the point where strategic decisions are made to redesign the company in response to these forces is often five or more levels of management. As a result, the time it takes to respond to major changes may be much longer than necessary, causing organizations to be reactive rather than proactive (the forefront of change). Requests for changes carry a heavy burden of documentation, justification, presentation and timing as they move up and down each of the several levels of management.

Organization of the future will seek to reduce the physical and psychological distance from the top to the bottom of their structure. The authority, responsibility and power necessary to deal effectively with rapidly changing conditions will be vested in the lower levels of the organization, where the factors relevant to decisions about change are most readily apparent and best understood. John Sculley at Apple moved in this direction by adjusting Apple's design so that territorial managers have greater discretion in deciding how Apple can meet the needs of major customers (educational or business) in their areas. Sculley also created rapid-response teams composed of the territorial manager, a production manager, and an ancillary product manager. This team has the authority to make significant decisions about how Apple will price, produce, and supply products for customers whose needs exceed certain levels.

### **Adhocracy and Porous Departments**

As organizations get larger, they begin to stifle the ability of subunits to make decisions and respond automatically to change. One of the major reasons for the success of the corporate raiders of the 1980s was the efficiencies to be gained by simply buying highly diversified companies and breaking them apart into their individual, separate businesses. The resulting freedom and flexibility often produced much more profitable businesses.

## **Organizations of the future will accept adhocracy:**

Federations of relatively autonomous units each of which can operate entrepreneurially. And within each unit, the structure will be more fluid or porous. Arbitrary barriers between and within departments will be less important – may even be removed – to allow people to “float” more between units, contribute to decisions, and get key jobs done.

## **Systems Decoupled from Structure**

Most organization structures are quasi-permanent. They stay in place for many years. It is not surprising that most of the systems that help “manage” the company – compensation, promotion, accounting, communication, and planning, to mention a few – are fitted to the structure of the organization.

If flexible structures such as adhocracy and fewer levels of management evolve, the supporting systems will have to stand alone. Promotions must be more than movements between slots in units and levels. Compensation must be linked to more than unit-related criteria. The key will be tailoring the systems to individuals rather than to organization units. Systems generally exist today to protect the company from human error. Systems of the future must enhance innovation which necessitates systems to decouple from structures and serve to enhance individual initiative, not limit it.

## **Sharing Rather than Dividing of Resources**

The systems that many organization use to make decision about the future and to commit resources to support those decisions is budgeting. Hence many managers are preoccupied with determining what resources they have to work with. Then, on the basis of that, they decide what they can do in the future. They ask, “What resources do we have under our control and what options do they allow us to pursue?” The central theme in this orientation is the need to identify and control the resources available.

Another system or orientation that many organizations are beginning to take seriously looks at the opportunities dictated by changing

environments as the true starting point for making future decisions. Managers with this orientation ask, “What opportunities are available to us?” Only after settling on a range of opportunities do they address the issue of resources: “What resources do we need [not “control;”] in order to pursue favorable opportunities?”. The manager who takes this approach seeks to borrow or temporarily use resources, not to own and control them. Resources are viewed simply as a means of pursuing attractive opportunities, not as things to accumulate as a source of organizational power. Managers in firms that employ this type of systems use company resources (people, facilities, money, capacity, technology, and marketing capability) only as long as they are needed. And because it is critical to make resources available in time for managers to seize the opportunities they discover, this system encourages access to resources in a manner that reduces paper work, levels of management through which decisions must travel, and the extent of “political” activity necessary to secure resources. Many people feel that this orientation – sharing rather than owning resources will be the most effective orientation for organization designs of the future.

### **Strategy and Organization Design**

The primary consideration in designing an organization is organization strategy. A well developed design enhances the accomplishment of strategic objectives, and these strategic objectives should be carefully selected to ensure successful organizational performance. Organization structure facilitates organizing the work, goals, relationship and decisions of an organization in such a way that people can perform to the best of their abilities. Thus the ultimate goal of organization design is to facilitate performance. A poorly conceived design can prevent high performance. In a well-managed organization, the connection among strategy, design and performance is strong.

Researchers have pointed out that an organization’s existing design also affects its strategy. For example, the design places power in the hands of a certain group of people, so there is a tendency among the members of this group to formulate strategies that preserve the status quo. It is not necessary to figure out whether strategy or design came first, or which has more impact, but it is critical to acknowledge the strong reciprocal relationship that exists between strategy and design.

## **Informal Organization and Culture**

The informal organization consists of the personal relationships and means of communication that are often necessary to accomplishing the work of the organization but are not a part of the formal organization structure. A related concept is the organization cultures the shared beliefs, attitudes and opinions about the company and what it stands for. The informal organization and the organization's culture are created by people throughout the company rather than being controlled by top management.

Informal organization and culture are important considerations in the overall design of an organization because of their influence on the behavior and performance of employees. In designing or redesigning an organization, management must always take the informal organization and the prevailing culture into account. If the organization's design clashes with its culture, it is most unlikely that the design will be effective. And where the design specifically attempts to frustrate part of the informal organization, harmful conflict may result.

## **Impact of Technology on Organizational Design**

Three factors have been found to have an effect on the design of an organization. The most appropriate design for an organization seems to be contingent on such variables as its environment, the complexity of its technology and its size. The organization's environment is an external variable, its technology has internal as well as external aspects; and its size is principally an internal factor.

## **Impact of Environment on Organization Design**

Organizations are influenced by the broader environment in which they exist. Government policy, societal values and social norms, economic trends, and the rate of technological change and innovation are general environmental factors that affect virtually any organization. And every business must adjust to its customers, competitors, suppliers and creditors – all of which are part of its immediate environment.

Managers of business design their organizations to take advantage of opportunities that arise in their environment and to respond to changes

in the environment. Most of the studies investigated the relationship between organization design and its environment and concluded that the best design for a given organization is contingent on the characteristics of its environment.

### **Environment Variability**

In assessing the possible impact of the environment on its design, an organization must consider the amount of variability in its environment – that is, the degree of change with which it must be prepared to cope. It must consider the frequency of change, the magnitude of change, and the predictability of change. An organization's environment may be stable, changing or turbulent.

### **Stable Environment**

A stable environment is one that experiences little or not unexpected or sudden changes. Products require only minor changes, if any, and the market shows very few fluctuations. For whatever reasons, the product attracts neither regulatory attention nor technological innovation. Consequently, organizations in a stable environment remain virtually unchanged for a long time. But stable environments are becoming scarcer. It is difficult to think of many organizations that have made the same product with the same process and sold it in essentially the same way for a long time.

Arms & Hammer is one organization with stable environment. It has been providing baking soda to similar markets for over one hundred years. The markets have grown, outlets for selling baking soda have changed, and additional uses for the product have been found, but the overall level and rate of change in the product and its markets have been minimal.

### **Dynamic Environment**

Dynamic environment is characterized by trends that are predictable. Thus organizations can be prepared to adjust to the changes when they occur. For example, the environment of many service firms could be characterized as changing. Trends in demand for services often



depend on the social fabric of society. Values and tastes certainly change over time, but these changes do not usually occur so unexpectedly or so rapidly that service firms cannot adjust to them. The characteristic flexibility of service firms helps them adapt rapidly to such changes. Firms that produce products can also predict trends in the environment. For example, Apple's decision to position itself more strongly in the business computer market was motivated in part by the overall decline in the student population (Apple's traditional strength), which resulted from changes in demographic trends that were apparent well before they actually affected the number of students.

Holiday Inn is another example of a company that is adjusting its business to predictable changes. In this case, changes in the social characteristics of potential lodging customers. Specifically, the rising number of women in the work force has created a need to ensure that lodging facilities accommodate female as well as male executives. And the declining number of families has reduced the emphasis on family centered accommodation.

### **Turbulent Environment**

Turbulent environment is marked by swift, frequent, and radical changes that occur with little or no warning. In the early stages of development of an industry, its environment is often turbulent as a new technology quickly emerges to replace an older one, new products or models are rapidly introduced to supersede yesterday's and (often) regulations are imposed to reign in the rapidly changing industry. Usually this turbulence is temporary, and the industry and its surviving organizations soon settle down into a less volatile state. The computer industry, however, is an exception. It has operated in a turbulent environment for several decades now.

Consumer electronic products constitute one of the most rapidly changing industries worldwide. A model introduced in one season of the year, such as a VCR, Camera, Cell Phone is often rendered obsolete by new models – and even new technologies – available the next season.

## Mechanistic Vs. Organic Structures

Some of the pioneering work on the relationship between organization design and environment was done by Tom Burns and G.M. Stalker. They found that successful organizations were designed differently in different environments. They distinguished between two types of organization design: *a mechanistic design and an organic design.*

**A mechanistic Design** follows Weber's bureaucratic model very closely in that it is characterized by specialized activities, specific rules and procedures, an emphasis on formal communication and a well-defined chain of command. Because mechanistic designs tend to be inflexible and resistant to change, this type of design is more successful in a stable environment. The U.S. Army offers a good example of a mechanistic design.

**In an organic design,** task activities are loosely defined. There are very few rules and procedures, and great emphasis is laid on self-control, participative problem solving and horizontal communication. Organic designs are more successful in dynamic, rapidly changing environments that require adaptability to change. Apple's early organization design was organic. The personal computer industry (which Apple pioneered) was rapidly changing, and this design was well suited to those early days of a new industry.

### *Comparison of Mechanistic and Organic Organizations*

Mechanistic	Organic
<ol style="list-style-type: none"><li>1. Tasks highly specialized; little regard paid to clarifying relationship between tasks and organizational objectives.</li><li>2. Tasks tend to remain rigidly defined unless altered formally by top management</li></ol>	<ol style="list-style-type: none"><li>1. Tasks are more interdependent. Emphasis on relevance of tasks and organizational objectives.</li><li>2. Tasks are continually adjusted and redefined through interaction of organization members.</li></ol>

<ol style="list-style-type: none"> <li>3. Specific role definition (rights, obligations, and technical methods prescribed for each member)</li> <li>4. Hierarchical structure of control, authority and communication. Sanctions derive from employment contract between employee and organization.</li> <li>5. Information relevant to situation and operations of the organization formally assumed to rest with chief executive.</li> <li>6. Communication is primarily vertical between superior and subordinate.</li> <li>7. Communications primarily take the form of (a) instructions and decisions issued by superiors and (b) information and request for decisions supplied by inferiors.</li> <li>8. Insistence on loyalty to organization and obedience to superiors</li> <li>9. Importance and prestige attached to identification with organization and its members.</li> </ol>	<ol style="list-style-type: none"> <li>3. Generalized role definition (members accept general responsibility for task accomplishment beyond individual role definition)</li> <li>4. Network structure of control, authority, and communication. Sanctions derive more from community of interest than from contractual relationship.</li> <li>5. Leader not assumed to be omniscient; knowledge centers identified where located throughout organization.</li> <li>6. Communication is both vertical and horizontal, depending on where needed information resides.</li> <li>7. Communications primarily take the form of information and advice.</li> <li>8. Commitment to organization's tasks and goals more highly valued than loyalty or obedience.</li> <li>9. Importance and prestige attached to affiliations and expertise in external environment.</li> </ol>
---	---

Burns and Stalker did not suggest that organizations should essentially adopt any one these two design models. They recognized that the environment surrounding each firm is unique and that each firm must design its structure accordingly. The mechanistic and organic designs are not “*either – or*” design options; rather, they exist at opposite ends of a

continuum along which an organization's design is characterized.

Later work by Paul Lawrence and Jay Lorsch supported Burns and Stalker's findings. Lawrence and Lorsch studied several firms in three different industries and found that more effective firms had designs that matched their environments. The effective firms in stable industries had mechanistic organization designs, whereas the most effective firms in turbulent industries had organic designs.

### **Impact of Technology on Organization Design**

As we have said, technology has internal as well as external dimensions. There is a tendency to associate technology only with factories and machines, but in terms of organization design, its meaning is much broader. Technology encompasses all the tools, equipment, processes, actions, materials, and knowledge required to convert an organization's inputs into outputs that can be distributed as useful goods or services. This definition makes it possible for such diverse activities as teaching students, dry cleaning clothes and assembling automobiles all to be considered technologies. In this sense, technology is an internal dimension; it is the way the organization goes about doing the work it exists to do. A Professor can teach a course with three hundred students in one class; another course might be restricted to thirty-five students. The former would probably require the lecture format, or technology, whereas the thirty-five student class could be taught via several technologies, including the case method, lectures, and group projects. Similarly, a dry cleaner can choose among several ways to provide dry cleaning services. In either example, the "technology" whereby the work is done may vary. And different technologies affect the degree of specialization or standardization necessary, the type of coordination mechanism needed, the levels at which decisions should be made and the optimal size of organizational units.

### **Joan Woodward**

Much of the pioneering work of the relationship between technology and organization design was done by Joan Woodward. She found that differences in technological complexity accounted for differences in the way effective organizations were designed. Her scale for measuring technological complexity consisted of three major categories: *unit and*

***small-batch technology, large-batch and mass production technology and continuous-process technology.*** Woodward assigned a firm's technological complexity to one of these three categories on the basis of the extent to which its manufacturing processes were automated and standardized.

***Unit and Small-batch Technology*** is consistent with the notion of a job shop. Custom-made items (such as tailored clothing) and items only one of which is produced (such as portraits) are examples of unit production. Small-batch technology is the production of small quantities of items with each production run. Print shops wherein each customer's order must be set and run separately utilize small-batch technology. Unit and small-batch technology is the least complex of Woodward's categories because it offers little opportunities for using automated and standardized techniques. Most of the work done by professionals such as doctors, lawyers and managers could be considered unit technology.

***Large-Batch and Mass-Production Technology:*** The most common example of large-batch and mass-production technology is an assembly line, where large number of the same product is produced. This kind of production utilizes mechanization and standardized parts. Almost all consumer durable goods such as automobiles and appliances are produced in this manner.

***Continuous-Process Technology*** utilizes fewer workers than does mass production, because most of the process is automated. A continuous stream of raw-material input is actually transformed into a continuous flow of output, not into separate, definable units. The process often changes the material composition of the inputs. Most refinery operations, such as petroleum, chemicals or sugar are considered continuous process technologies. This category is the most complex in Woodward's scheme, because the processes involved are almost always completely automated.

Woodward found that several design components varied with the organization's type of technology. As technological complexity increased, the number of levels of management increased (that is, the organization structure became taller), the span of control of top management increased, and the ratio of line to staff workers increased. However, the span of control for lower-level managers was greater for technologies intermediate in complexity. This is probably because large-batch and mass-production

technologies require numbers of workers than do either unit or continuous-process technologies.

Woodward's findings indicated that organizations characterized by the most complex (continuous-process) and the least complex (unit and small-batch) technologies tended to have more organic designs. Organizations exhibiting technologies in the middle range of complexity (large-batch and mass-production technologies) had more mechanistic designs. Most important, she found that the most successful organizations followed this pattern. Therefore, it is evident that technology is an important determinant of appropriate structure.

### **James Thompson**

Several years after Woodward's British studies, an American researcher, James D. Thompson divided technologies into three categories on the basis of years of observation in different organizations. He labeled technologies as *long-linked, mediating or intensive*.

#### ***Long-Linked Technology:***

Thompson's long-linked technology is characterized by a series of sequential tasks that must be performed in a specified order. The assembly line is an example of long-linked technology. This category closely parallels Woodward's large-batch and mass-production technology.

#### ***Mediating Technology:***

Is a process that brings together groups that need to be interdependent for the desired action to take place. For example, banking is a mediating technology; it facilitates the interaction between depositors and borrowers. Employment and other talent search agencies connect suppliers of specialized labor with buyers. This type of technology is intermediate in flexibility. It allows for some standardization but can also adjust its output in response to variations in the needs of the parties it seeks to link.

## **Intensive Technology:**

An intensive technology involves the application of specific skills, techniques or services in order to make a change in an input. This type of technology describes custom work and is consistent with Woodward's unit production technology. The value of an intensive technology is its flexibility.

Environment and technology are not the only critical factors shaping organization design decision. The sheer size of an organization often plays a central role in organization design.

## **Size**

The impact of the sheer size of an organization on its design has attracted a great deal of research attention. It seems obvious that organizations change as they get larger and that more complex designs become necessary. But the research results are not unanimous. This may be due in part to the fact that size has been measured in a variety of ways.

## **Review Questions**

1. What are the emerging trends in corporate structure? Explain.
2. Explain the relationship between strategy and organization design.
3. Explain the role of culture in acceptable formal and informal organization.
4. Describe the impact of environment on organization design.
5. What are environmental variables that will have impact on organization design?
6. Distinguish between Mechanistic design and Organic design?
7. Explain the impact of Technology on organization design.

\*\*\*





---

## Lesson - 13: Formal And Informal Organization

---

### Objectives

*After reading this lesson, you should be able to:*

- ▶ Understand The Concepts Of Formal And Informal Organization;
- ▶ To Appreciate The Existence Of Informal Organization In The Formal Organization; And
- ▶ Know The Differences Between Formal And Informal Organization.

### Lesson Outline

- ▶ Formal Organization.
- ▶ Informal Organization.
- ▶ Differences Between Formal And Informal Organization.
- ▶ Review Questions

Formal organization, which refers to the structure of well-defined jobs, each bearing a definite measure of authority, responsibility and accountability, is not capable of accomplishing organizational objectives all alone. It needs the help of informal organization for this purpose. In other words, informal organization, which does not appear on the organization chart, supplements the formal organization in achieving organizational goals effectively and efficiently.

### Formal Organization

Chester I Barnard defined formal organization as “a system of consciously coordinated activities or forces of two or more persons”. A formal organization is deliberately designed to achieve specific objectives. It refers to the structure of well defined jobs, each bearing a definite measure of authority, responsibility and accountability. The structure is consciously designed to enable the people of the organization to work

together for accomplishing common objectives. Thus, formal organization is more or less an arbitrary structure to which the individual must adjust. It tells him to do certain things in a specified manner, to obey orders from designated individuals and to cooperate with others. Coordination also proceeds to a prescribed pattern in the formal organization structure.

The formal organization is built around four key pillars; namely,

- i. ***Division of Labour,***
- ii. ***Scalar and Functional Processes,***
- iii. ***Structure, and***
- iv. ***Span of Control.***

These may also be called principles of formal organization. Division of labour and specialization is the basic principle of formal organization. The whole work is divided into a number of small operations and each operation is performed by a different person so that there is maximum specialization. The scalar and functional processes imply the growth of the organization both vertically and horizontally. The structure of the organization refers to the overall arrangement in the organization which ensures proper balance between different parts of the organization and secures the execution of all operations and the achievement of organizational objectives. The span of control refers to the number of subordinates directly reporting and accountable to one superior.

Formal organization is the official hierarchy as it appears on paper. It is the basis and official version of the organization. Formal organization possesses the following characteristics:

1. It is deliberately impersonal;
2. It is based on ideal relationships; and
3. It is based on the rabble hypothesis of the nature of man.

These characteristics have also been criticized by many authors. Firstly, as formal organization is deliberately impersonal, emotions and sentiments of individuals are ignored in determining the interactions, communication and accountability. But human beings cannot live without social relations and, that is why, they develop informal relations. Secondly, it is based on ideal relationships, human beings are thought to be rational and economic beings. Further, it is assumed that there would be no unofficial channel of communication. But it is very difficult to find such

ideal relationships in actual life. Lastly, it is based on the rabble hypothesis of the nature of man. It is assumed that there will always be the same kind of reaction if human beings are punished or rewarded. But the individuals are not always motivated by the same rewards or punishments in the same manner.

Formal organization is deliberately construed to achieve some goals. It sticks to the goals (as laid down by the originators). Goals are not easily changeable with the passage of time. This is another point of criticism put forward by its critics. The rules and regulations of the organization may be too rigid that it becomes difficult to achieve the goals. Moreover, formal organization does not consider the goals of the individuals. Because of these reasons formal organization usually gives birth to informal groups which cannot be separated from it. As a matter of fact, there is a close relationship between the formal and informal organizations. Management should not ignore informal organization (informal group, informal leader, informal communications, etc.) but it should use it to achieve the organizational goals.

### **Informal Organization**

Informal organization refers to the relationship between people in the organization based on personal attitudes, emotions, prejudices, likes, dislikes, etc. These relations are not developed according to procedures and regulations laid down in the formal organization structure. Generally, large formal groups give rise to small informal or social groups. These groups may be based on some similarities that people of a large group see among the members of the group with respect to tastes and preferences, socio-cultural background, temperaments, attitudes, etc.,. These groups are not preplanned, but they develop automatically within the organization according to its environment.

Informal organizations are small groups and these groups can overlap because a person may be a member of several different informal groups. A manager cannot abolish the informal groups since he does not create them. Informal relations will always support and supplement the formal one. There are certain disadvantages also of informal organizations. They put resistance to change and conform to old practices. The communication in informal organization is very fast. Sometimes, it

creates rumors which may prove dangerous to the enterprise.

Modern authors on organization behavior view organizations as consisting of both types of relationships, i.e., formal and informal. It is true that while laying out an organization plan, management can only develop formal structure of relationships, but organization is not only a form chart or structure of relationships. Formal organization, no doubt, is an important part of the organization. But informal organization is also not less important. If handled properly, it will help in performing the activities of the organization very efficiently and effectively. In short, informal relations are complementary to formal relations and procedures laid down in the organization structure. Both formal and informal organizations are necessary for any group action just as two blades are essential to make a pair of scissors workable.

### **Making Better Use of Informal Organisation**

The management should not look down upon the informal organization as it arises spontaneously along with the formal organization and fills in some of the vital gaps in the formal organization. It may be noted that formal organization is unable to meet all the needs (e.g. affiliation, affection, esteem, etc.) of its members. Management can fulfill these needs of the workers by encouraging informal organization as it provides a buffer to absorb the shocks of tensions and frustrations among the members as a result of formal organizational pinpricks.

Informal organization may act to fill in gaps in a manager's abilities. For instance, if a manager is weak in planning, one of his subordinates may informally help him in such a situation. Management may also make use of informal group leaders by taking them into confidence to mediate as bridges of understanding between the management and the employees. Startle has rightly said, "Informal structure is one index of the dynamics of getting work done and it appears that, for efficiency, it will necessarily deviate from the formal structure". Therefore, management should adopt a positive attitude towards informal organization. It should use it along with formal structure to make workable system for achieving the organizational objectives.

Most informal groups tend to be small. Each has its leader, who was not elected or appointed, but earned the status because of age, seniority on the job, dominant personality, special capability, physical strength or some other characteristic. However, in large informal organizations, there may be more than one leader whom the group will follow under given circumstance. An individual with more formal education than the others may be looked to in matters that require formal communication. He may be asked to speak for the group in dealings with management, the union, or other informal groups. Another members possessing more job experience and “know-how” may be consulted when direction or guidance is needed in handling a work assignment or solving some problems connected with it. A manager should identify informal leaders and work with them.

A manager can build favorable relations with informal leaders in several ways. He can consult the leaders and seek their advice on technical matters or human relations problems. He can request their assistance and cooperation in inducting new members and training them to become competent workers in their formal job assignments. Open, two-way communication can be encouraged on a continuing basis for mutual benefit. A manager must be careful not to reduce the status of the leader in the eyes of his constituents. Informal communication system though may have certain ill consequences, can also be used by an enlightened manager to plug the loopholes of the formal communication system. Informal communications is very fast and ensures speedy transmission of information. It is the duty of every manager to see that informal communication does not produce rumors and if a rumor spreads, it should not be allowed to damage the functioning of the organization. In short, management can use every aspect of informal organization to achieve the organization objectives.

### **Differences between Formal and Informal Organization**

The formal and informal organizations differ from each other in the following respects:

- i. **Origin:** The reason and circumstances of origin of both formal and informal organizations are totally different. Formal organizations are created by conscious managerial decisions. But informal organizations arise naturally within the formal organization

because of the tendency of the individual to associate and interact. Management has no hand either in emergence or in abolition of informal groups.

- ii. **Purpose:** Formal organizations are created for realizing certain well-defined objectives. But informal groups are created by organizational members for their social and psychological satisfaction. There may be a conflict between the goals of the formal organizations and those of the informal groups.
- iii. **Activities:** Activities in case of formal organization are differentiated and integrated around the objectives of the enterprise and are formalized into work units or departments on a horizontal basis. Individuals are fitted into jobs and positions and work groups as a result of managerial decisions. In case of informal organization, there are no specific activities. They arise from time to time as result of interactions and sentiments of the individuals. Informal groups may be based on common taste, language, culture or any other factor.
- iv. **Structure:** Formal organization is hierarchical, pyramid shaped and bureaucratic in structure with well defined positions, rigid delineation of roles and superior – subordinate relationships on impersonal basis, enforcement of organizational order through a set of policies, procedures, and rules, conscious emphasis on status, differential based on authority, narrow and downward oriented communication system, etc. On the other hand, informal organization is looks like a complicated and common social network of interpersonal relationships. Informal organization is loosely structure, with only unwritten norms of behavior enforced by consent. Communication is informal and multi directional. There are no rigid status differentials.
- v. **Membership.** In a formal organization, every individual belongs to one work group only and works under one superior. But in case of informal organization, one person can be a member of more than one group, according to his choice. He may be a leader in one group and a follower in another. There is no rigidity about group membership.

- vi. **Orientation:** In case of formal organization, values, goals and tasks are dominantly economic and technical and they are concerned with productivity, profitability, efficiency, survival and growth. But in the case of informal organization, values goals and tasks are dominantly psycho-social, setting around individual and group satisfaction, affiliation, cohesiveness and friendship.
- vii. **Norms of Behavior:** In a formal organization, individuals are required to behave in the prescribed manner in their work situations. They are expected to behave in a rational manner. Deviations from the standard norms are dealt with according to the processes of organizational law and order. There is also a system of rewards and punishments. But in case of informal organization, individual behavior and group behavior influence each other. Behavior is more natural and social.

Interactions cut across formally established positions and relationships and there is free exchange of feelings and ideas. An informal organization develops its own norms of behavior and a system of rewards and punishments to ensure adherence of group norms.

### **Review Questions:**

1. Define formal organization and explain its features.
2. Give a comparative assessment of the importance of formal and informal organization.
3. Distinguish between formal and informal organization. What should be the attitude of management towards informal organization?
4. How Can informal organization undermine and distort the formal organization? Explain

## Case Study

Mr. Srinivasa Raghavan, the Chairman of the Best Food Products Company, was tired of being the only one in the company actually responsible for profits. While he had good vice-presidents in charge of finance, sales, advertising, manufacturing, purchasing, and product research, he realized he could not hold any of them responsible for company profits, as much as he would like to. He often found it difficult even to hold them responsible for the contribution of their various areas to company profits. The sales vice-president, for example, had rather reasonably complained that he could not be fully responsible for sales when the advertising was ineffective, when the products wanted by customers were not readily available from manufacturing, or when he did not have the new products he needed to meet competition. Likewise, the manufacturing vice-president had some justification when he made the point that he could not hold costs down and still be able to produce short runs so as to fill orders on short notice; moreover, financial controls would not allow the company to carry a large inventory of everything.

Mr. Raghavan had considered breaking the company down into six or seven segments by setting product divisions with a manager over each with profit responsibility. But he found that this would not be feasible or economical since many of the company's branded food products were produced on the same factory equipment and used the same raw materials and a sales person calling on a store or supermarket could far more economically handle a number of related products than one or a few.

Consequently, Mr. Raghavan came to the conclusion that the best thing to do was to set up six product managers reporting to a product marketing manager. Each product manager would be given responsibility for one or a few products and would oversee, for each product, all aspects product research, manufacturing, advertising and sale thereby becoming the person responsible for the performance and profits relating to the products.

Mr. Raghavan realized that he could not give these product managers actual line authority over the various operating departments of the company since that would cause each vice-president and his department to report to six product managers and the product marketing manager,



as well as the president. He was concerned with this problem but knew that some of the most successful larger companies in the world had used the product manager system. Moreover one of his friends on a university faculty told him that he must expect a certain amount of confusion in any organisation and that this might not be bad since it forced people to work together as teams.

Mr. Raghavan resolves to put in the product manager system in his organisation as outlined and hoped for the best. But he wondered how he could avoid the problem of confusion in reporting relationships.

### **Questions**

1. Do you agree with Mr.Raghavan's programme? State the exact problem in the case.
2. What would you do to avoid any confusion in this organisation?
3. Do you suggest any other organisation model for this business? If so, present the organisation chart of the same.

\*\*\*



## UNIT-III

---

### Lesson - 14 : Perception And Learning

---

#### Objectives

*After going through this lesson, you should be able to:*

- ▶ Understand The Perceptual Process And The Influencing Factors Thereof;
- ▶ Identify The Factors Determining The External And Internal Stimuli;
- ▶ Examine The Various Learning Theories; And
- ▶ Distinguish Between Positive And Negative Reinforcements Influencing The Learning Behavior.

#### Lesson Outline

- ▶ The Perceptual Process
- ▶ Factors Influencing Selection Of Stimuli
- ▶ Factors Influencing Perception
- ▶ Managing The Perception Process
- ▶ Learning Theories
- ▶ Learning Reinforcement
- ▶ Review Questions

Perception is how people look at and understand the things. It is a unique interpretation of the situation rather than recoding of it. Perception is a complex cognitive process of understanding the world, sometimes not in its real form. Perception is a learning process and hence it differs from person to person. As a result, the same stimuli may produce different behaviours and responses. In managing the organizations, particularly in dealing with the people, managers should be able to understand the perceptions of the people. It is in this context, an attempt is made here to explain the perceptual process, factors influencing perceptions and managing the perceptions to the advantage of the organization.

## Perceptual Process

Perception is the process by which people select, organize, interpret and respond to information from the world around them. This information is obtained through the senses namely, seeing, hearing, touch, taste and smell.

Perception may be defined as the process of receiving, selecting, organizing, interpreting, checking, and reacting to sensations. It is also defined as *'a process by which individuals organize and interpret their sensory impressions in order to give meaning to their environments.'* The perceptual processes show that their functioning is affected by three variables – the objects perceived, the environment in which perception occurs, and the individual perceiving the objects.

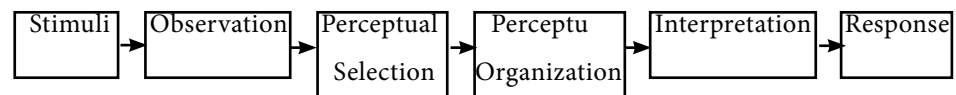

**Figure 14.1: The Perceptual Process**

In the above diagram, you may find that the important aspects of perception are selection and organization. Different people perceive an object differently both in terms of what they selectively perceive and how they organize and interpret the things perceived. A person's selection process involves factors internal to the person as well as external to him. It is, in fact, a complex set of factors that determine the perception of an individual.

Similarly, an individual organizes the selected stimuli into meaningful patterns. The interpretation of what is perceived may vary widely. For example, a wave of hand may be interpreted as a friendly gesture or it may be interpreted as a sign of threatening depending on the circumstances and the state of mind of the two people. Therefore, quite often the people perceive things differently and behave on the basis of those perceptions. Managers in organizations should understand that people's perceptions differ and at times they also go wrong.

## **External Factors Influencing Selection**

The external factors influencing selection are nature, intensity, size, contrast, repetition, motion, and novelty and familiarity.

### **Nature**

By this we try to understand the nature of the object. Is it a visual object? Does it have words, pictures, people or animals? Pictures attract attention more than words and a picture with human beings attracts attention more than a picture with inanimate objects. That is why cartoons and caricatures draw more attraction.

### **Intensity**

The intensity principle conveys that if the external stimulus is more intense in nature, the more it is likely to be perceived by the individual. That is why people pay more attention to loud noise, strong odour or bright light. At work places, superiors speak loudly to subordinates for this reason only.

### **Size**

Like intensity, size also matters very much. Larger objects are likely to be perceived more by the individuals than the smaller ones. A maintenance engineer gives greater attention to a bigger machine than a smaller one.

### **Contrast**

The contrast principle suggests that the external stimulus that stands out distinctly against the background or the one that is quite unusual will receive greater attention of the people.

### **Repetition**

The principle of repetition suggests that a repeated external stimulus draws more attention than a single one. The several advertisements of various products shown daily on TVs are based on the principle of repetition only. This principle also explains why supervisors have to give directions to workers repeatedly for even simple tasks.

## **Motion**

According to this principle, people pay greater attention to moving objects rather than stationary objects. That is why advertisers create signs that incorporate moving parts.

## **Novelty and Familiarity**

This principle states that either a novel or a familiar external situation can better serve to draw attention. New objects in familiar settings or familiar objects in new settings are likely to draw the attention of the perceiver. Job rotation is followed in organizations for this reason. For instance, workers will pay greater attention to the tasks assigned to them in the new jobs in order to prove themselves and gain acceptance in the new job.

## **Internal Factors Influencing Selection**

Internal factors influencing selection of stimuli are personality, learning, and motivation. They are explained below.

### **Personality**

It cannot be disputed that personality has a significant impact on what and how people perceive. The various personality dimensions influence the perceptual process. A conscientious person is likely to pay greater attention to external environmental stimuli than a less conscientious person who is likely to be careless, impulsive and irresponsible. On the other hand, conscientious people tend to organize their perceptions into clear categories, receive information quickly and in an organized manner. They are careful and methodical in their perceptual selection and organization.

### **Learning**

Perceptual selection is also affected by learning. Learning determines the development of perceptual sets. Perceptual set means the expectation of particular interpretation based on past experience with the same object. This is also known as cognitive awareness by which the minds

organizes information and form images and compare them with previous exposures to similar stimuli. In organizations employees' experiences are influenced by their perception very much. In making decisions, managers are also influenced by their functional background. However, it is necessary for managers to rise above their own experiences and be able to solve the problems in an appropriate way. Individual differences lead to perceptual bias. This bias can be overcome through education and experience.

### **Motivation**

Motivation also plays an important role in influencing the process of perception. For example, a hungry person is likely to be sensitive to the sight or smell of food than a non hungry person. Likewise if the person is deprived of sleep, he looks for a situation in which he can have a comfortable sleep. Generally, people perceive things that help in satisfying needs and those that were found rewarding in the past. The relationship between motivation and perception is explained through Collenyannia Principle which states that people process pleasant events more efficiently and accurately than the unpleasant events.

### **Factors Influencing Perception**

A number of factors operate to shape and sometimes to distort perception. These factors emanate from three sources – the perceiver, the perceived and the situation.

#### **The Perceiver**

When a person looks at a target, his interpretation of it is influenced by his personal characteristics like his needs, past experience, habits, personality, values, and attitudes. A person with a strong need for ego satisfaction may select out from a situation and emphasize signals that tend to satisfy the desire for self esteem. Similarly, negative attitudes toward unions may cause a manager to look for antagonisms in even routine visits by local union officials to the organization. These and other personal factors will determine what a person gives attention to in a situation and how these cues are interpreted as a basis for decision-making and action responses.

## The Perceived

Characteristics in the target / object that are being observed may influence what is perceived. The physical attributes, appearance, and behaviour of other persons in the situation also influence how the object is perceived. Physical attributes of a person are related to age, sex, height, and weight. A young person exercising authority in a situation is viewed differently from an older person doing the same thing. Personal attire and appearance are also relevant factors in the formation of perceptions.

## The Situation

The context in which we see the objects or events is important. The physical, social and organizational elements of the situation or event may also influence perceptions. A subordinate calling his boss by the first name may be perceived quite differently when observed in a typical Indian office as opposed to in a social reception. Though the perceiver and the perceived are the same, it is the situation that makes a difference. Such background characteristics of the situation or context are additional factors that can affect how the situation is perceived by the different persons. The following Diagram shows the summary of the factors influencing perception.

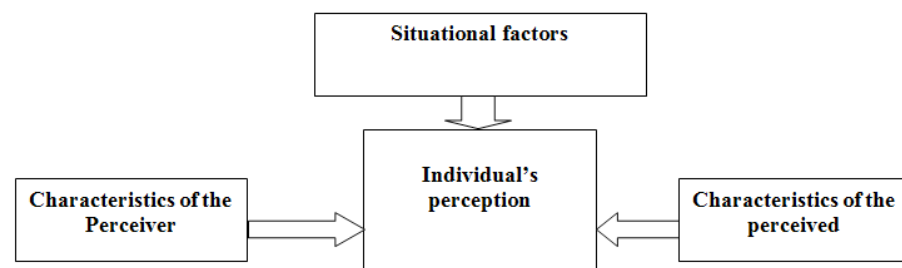

**Figure 14.2: Factors Influencing Perception**

## Managing the Perception Process

Successful managers understand the importance of perceptions as influences on behaviour, and handle them accordingly. They are aware of perceptual distortions and accept that perceptual differences are likely to exist in any situation. With this knowledge, they make appropriate decisions that are acceptable to all persons concerned. The perceptual skills of a manager will help him in the following ways.



### **High level of self awareness**

As already made clear, individual needs, experience, and expectations will all affect perceptions. The successful manager understands this and is able to identify when he is inappropriately distorting a situation because of such perceptual tendencies.

### **Seek information from various sources for decisions**

The successful manager minimizes the bias of personal perceptions by seeking out the viewpoints of others. These insights are used to gain additional perspective on situations and the problems or opportunities they represent.

### **Empathy**

As is understood, different people look at the same situation differently. The successful manager rises above the personal impressions and tries to understand problems as felt by other people.

### **Influence of perceptions on other people**

People act according to their own perceptions. If felt necessary, the successful manager influences the perceptions of others in such a way that the work events are interpreted as accurately as possible and to the advantage of all concerned.

### **Avoid common perceptual distortions**

Perceptual distortions include the use of stereotypes and halo effects, as well as selective perception and projection. Successful managers are self disciplined and sufficiently aware that the adverse impact of these distortions is minimized.

### **Avoid inappropriate attributions**

A person has a tendency to explain why events happened the way they did or why people behaved as they did. The successful manager is wise enough to establish the real reasons for the things that happen and avoid

the tendency of making quick or inappropriate attributions.

## **Learning**

Now, let us understand the term 'learning' and the various processes of learning. Learning is any relatively permanent change in behaviour that occurs as a result of experience. There are two important elements in learning:

- a. Change must be relatively permanent. It means after 'learning' the behaviour of a person must be different from the previous behaviour. If a person learns car driving, it will last for a long time indicating the changed behaviour. Temporary changes may be only reflexive and fail to represent any learning. Therefore, this requirement rules out behavioural changes caused by fatigue or other temporary adaptations.
- b. The second element is that the change of behaviour should take place as a result of some kind of experience. Learning must be because of some interaction with the environment and some feedback from such environment that affects behaviour. The experience may be direct or indirect. Sometimes we learn to change our behaviour when our colleagues are punished for that kind of behaviour.

You may note that learning itself cannot be observed. The behavioural changes consequent upon learning only can be seen. This kind of change in behaviour should be differentiated from change in behaviour caused by other factors. For example, aging may cause behavioural changes. A change in the individual's thought process or attitudes, if accompanied by no change in behaviour, would not be learning.

Learning certainly has its own impact on training activities in an organization. It can give insights into how to best develop the skills and talents of employees for performing the jobs effectively. But it is the desire to change individuals that is of the greatest importance. The manager who undertakes to produce such changes acts like a teacher. He guides the employees to engage in behaviours that will help the organization achieve its objectives. When the employees are late for work, lazy, disobey the rules or engage in any type of dysfunctional behaviour, the manager attempts to teach behaviours of functional nature. Further, if the employee

is performing well, he gives the employee feedback and also rewards to strengthen such desirable behaviour.

You may understand that individuals enter an organization with a host of learned attitudes and behaviours. Their job performance is a function of their learned experiences. Learning is a continuous experience for employees. It is because of learning, employers recruit people with college degrees or those with job experience. The employer presumes that not only education or experience provides learning, but that learning will lead to higher job performance.

## **Learning Theories**

In an organization, employees have to learn and practice productive work behaviours. The manager's task is to provide sufficient learning experiences to employees in an environment that will facilitate learning process and promote desired behaviours. Training prepares employees to meet the challenges of the job, for which incentives are to be provided to learn and practice right behaviours. The following are the important theories of learning.

### **Classical Conditioning**

Classical conditioning is the process by which individuals learn to link the information from a neutral stimulus to a stimulus that causes a response. This response may not be under an individual's conscious control. Pavlov, in his experiments, hanged some meat in front of dogs. This meat is unconditioned stimulus or unlearned stimulus. The dogs responded to this stimulus by salivating. This kind of response was instinctive or unconditioned. Afterwards Pavlov started to ring a bell at the same time when meat was offered. Ringing the bell without offer of meat was not connected to any responses. However, by ringing the bell every time when meat was offered, Pavlov established a relationship between the two stimuli that is the bell and the meat. With the continuation of the process, the ringing of the bell alone acted like a stimulus to evoke the response of salivating even without presentation of meat. As a result, the bell became a conditioned stimulus leading to conditioned response.

## **Operant Conditioning**

B.F. Skinner coined the term operant conditioning to refer to a process by which individuals learn voluntary behaviour. Voluntary behaviours are called operant because they operate or have some influence on the environment. Learning occurs from the consequences of behaviour, and many employee work behaviours are operant behaviours. As a matter of fact, most behaviours in everyday life are forms of operant behaviour. Managers are interested in operant behaviours because they can influence the results of such behaviours. On the basis of the direct relationship between the consequences and behaviour, the management can identify the relationship and try to modify the behaviour. That is how the behaviour can be controlled by manipulating its consequences. Two principles guide this relationship.

- The behaviour that results in positive rewards is likely to be repeated and behaviour with negative consequences is likely to be extinguished.
- Based on such consequences, the behaviour can be predicted and controlled.

Therefore, some consequences can be used to increase the recurrence of desired behaviour and some other consequences can be used to decrease the recurrence of undesired behaviour.

## **Principle of Reinforcement**

We understand that some behaviours are strengthened by the process of reinforcement. Reinforcer may be any stimulus that prompts a behaviour to be repeated or stopped. Managements expect that the employee should behave in a desirable manner in the organization and avoid undesirable behaviour. By the appropriate use of reinforcers, the organizations are able to maintain or increase the probability of behaviours like quality oriented performance, wise decision making, regular attendance and punctuality and so on. Some reinforcers work by their application to a situation whereas other reinforcers work by their removal from this situation.

## **Positive Reinforcement**

Positive reinforcement is provided by offering rewards for desired behaviours. Such rewards should be powerful and durable so as to increase the probability of occurrence of desirable behaviour. Money, as you understand, is the most powerful reinforcement for positive behaviour since money can be used for a number of other purposes. Some other positive reinforcers are recognition for good performance, challenging task, participation in decision making and so on. As individuals have different motivations of performance, positive reinforcers should be individually tailored with a view to facilitate the repetition of desired behaviour. That means reinforcer must be valued by the employee. For example, money would be a less reinforcer who values praise for his performance more. The reward must be directly linked with behaviour so that the higher the performance of an employee, the greater would be the reward.

## **Negative Reinforcement**

In negative reinforcement, an unpleasant event that precedes the employee behaviour is removed when the desired behaviour occurs. This procedure increases the likelihood of the desired behaviour to follow. Negative reinforcement is sometimes confused with punishment because both use unpleasant events to influence behaviour. However, negative reinforcement is used to increase the frequency of a desired behaviour, whereas punishment is used to decrease the frequency of an undesired behaviour. Managers frequently use negative reinforcement when an employee hasn't done something that is desired.

## **Omission**

Omission is the removal of all reinforcing events. While reinforcement increases the frequency of a desirable behaviour, omission decreases the frequency and eventually extinguishes an undesirable behaviour. Managers use omission to reduce undesirable employee behaviours that obstruct achievement of organizational goals. The omission procedure consists of three steps.

1. identifying the behaviour to be reduced or eliminated,
2. identifying the reinforcer that maintains the behaviour, and

3. stopping the reinforcer.

Omission is a useful technique for reducing and eventually eliminating behaviours that disrupt normal workflow.

### **Punishment**

Punishment is an unpleasant event that follows a behaviour and decreases its frequency. As in positive reinforcement, a punishment may include a specific antecedent that cues the employee that a consequence will follow a specific behaviour. While a positive consequence of reinforcement encourages the frequency of a desired behaviour, a consequence of punishment decreases the frequency of an undesired behaviour.

Organizations typically use several types of unpleasant events to punish individuals. They may be a wage cut, a suspension without pay, a demotion, or a transfer. The severe punishment is the dismissing an employee for failure to perform. In general, organizations use punishments of unpleasant nature sparingly for cases of serious behavioural problems.

It may be kept in mind that punishment should be used as a last resort. The use of punishment should be limited to those undesirable behaviours that cause a significant damage to the organizational operations. It may also be remembered that punishment should not lead to hostility to such an extent of making solution more harmful than the problem itself. Punishment may cause undesirable emotional reactions. An employee who has been reprimanded for a mistake may react with anger toward the manager and the organization. Such reactions may lead to retaliatory behaviour harmful to the organization. Sabotage, you remember, typically is a result of a punishment-oriented management system. It is clear that punishment leads to short-term suppression of the undesirable behaviour, rather than to its elimination. Further, the punished individual may develop a tendency of avoiding the situation. High absenteeism is a form of avoidance and quitting is the final form of escape.

You should also note that punishment suppresses employee initiative and flexibility. Overusing punishment produces apathetic employees, who are not assets to an organization. Sustained punishment can also lead to low self-esteem. Low self-esteem, in turn, undermines the employee's self-confidence, which is necessary for performing most of the jobs.

## **Review Questions**

1. Explain the perceptual process and the factors influencing the perception?
2. Examine with suitable examples from the real world how a sound knowledge of perception helps a manager in managing people and situations?
3. What is learning? Explain any two learning theories you are familiar with?
4. Distinguish between positive and negative reinforcement?

\*\*\*





---

## Lesson - 15 : Personality And Individual Differences

---

### Objectives

*After going through this lesson, you should be able to:*

- ▶ Grasp The Meaning Of Personality;
- ▶ Understand The Factors Contributing For Personality Development;
- ▶ Gain The Knowledge Of Various Personality Theories; And
- ▶ Find Out The Impact Of Personality Differences On Behavior.

### Lesson Outline

- ▶ Meaning And Definition Of Personality
- ▶ Determinants Of Personality
- ▶ Theories Of Personality
- ▶ Personality Traits And Their Impact On Behaviour
- ▶ Review Questions

### Meaning and Definition of Personality

Personality is a complex phenomenon and difficult understand. There is no single universally acceptable definition. Personality refers to the personal characteristics that lead to consistent patterns of behaviour. It represents the overall profile or combination of stable characteristics that capture the unique nature of a person. Personality combines a set of physical and mental characteristics that reflect how a person looks, thinks, acts and feels. It has both internal and external elements. External traits are observable behaviours on the basis of which we can understand one's personality. The internal factors are thoughts, values and genetic characteristics that are inferred from the observable behaviours. According to Hogan, *personality refers to the relatively stable pattern of behaviours and consistent internal states that explain a person's behavioural tendencies.*

We can understand from the above definition that people have some traits in common with others and some uncommon with them. Each employee in an organization is unique and he may or may not act similarly in a similar situation. Therefore, managers cannot use the same kind of rewards or motivation techniques to influence employee's behaviour. The above definition does not mean that people do not ever change. It simply indicates that individuals do not change drastically overnight and their thoughts, feelings, values, and actions remain relatively stable over time. Personality changes in individuals occur slowly over an extended period of time. However, an understanding of personality dimensions would enable managers to predict the behaviour of employees and manage them effectively.

### **Determinants of Personality**

Having understood the concept of personality, now we can move further to know how an individual's personality is determined? Is it inherited (genetically determined) or is it formed after years of experience? There are no simple answers to these questions. In fact, several factors influence the shaping of our personality. Primarily, there are two sources contributing for personality differences. They are i. heredity and ii. environment. Environment has several factors within it like culture, family background, life experiences and the groups we interact with. The following diagram shows how personality is shaped by these factors.

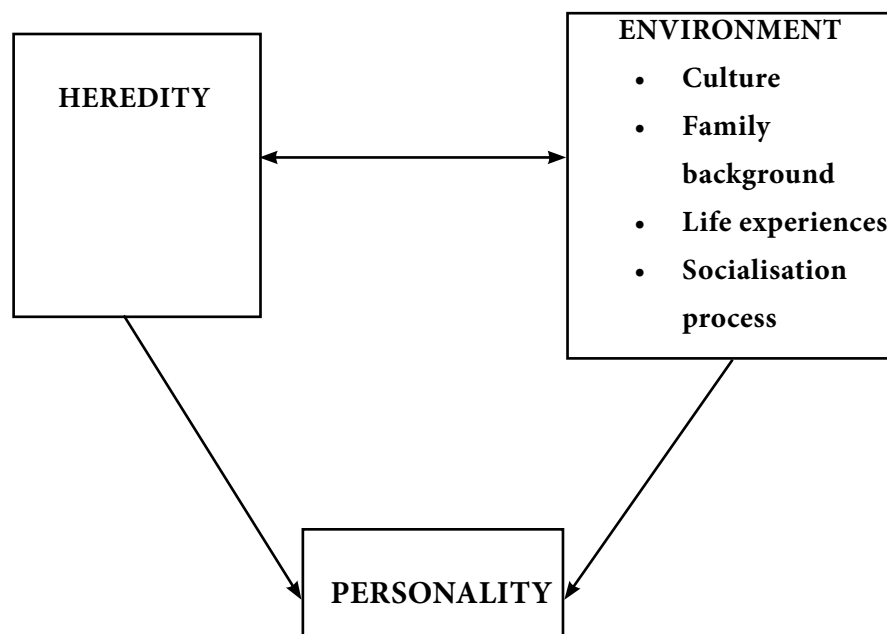

**Figure 15.1: Determinants of Personality**

## **Heredity**

Our personality is partly inherited genetically from our parents. For example, whether we are fair or dark, tall or short, strong or weak are all characteristics that have something to do with heredity. Personality characteristics are partly influenced by environmental factors also like experiences in life. Some traits may have strong genetic component while others may be largely learned.

## **Culture**

Culture refers to the distinctive ways in which people organize and live their lives. Hence people belonging to different societies will have different cultural orientations. Persons born into a particular society are exposed to family and societal values and to norms of acceptable behaviour in the culture of that society. People in the West and those in the East have cultural differences between themselves. In US culture, people are rewarded for being independent while in Japanese culture they are rewarded for being group oriented. These differences are primarily due to variations in cultural norms and expectations of acceptable behaviours in the respective societies. You may also note that though cultural values may have an impact on personality differences among people in different cultures, people born in the same culture may also differ from each other in many characteristics. Managers should keep this in mind when they are dealing with the employees.

## **Family Background**

An important tool of socializing a person into a particular culture is the person's immediate family. Factors like the socio-economic status of the family, the number of children in the family and birth order, and education of the parents and extended members of the family such as cousins, uncles and aunts influence personality formation. In this regard, you may note that parents' influence on children's development is significant and it happens in three ways:

- i. Through their own behaviours they influence children's behaviours;
- ii. They serve as role models; and
- iii. They selectively reward and punish the behaviour of children.

## **Experiences in Life**

Perceptions, ego, temperaments, and self esteem, are all related to ones past experiences.

A complex set of events and interactions with other people determine the level of self esteem of a person. Therefore, some personality traits get changed positively or negatively on the basis of the kind of experiences in one's life.

## **Groups we interact with**

The first group of people, a person interacts with is the family. As they grow, people participate in various groups in the life time. The roles and experiences people have as members of different groups lead to personality differences. People influence each other and tend to associate with members who are similar to them in their attitudes and values. The interactions begin first with parents and siblings, then teachers and classmates, later on friends and colleagues. Undoubtedly, the influence of groups and various individuals will shape our personality. For example, if a person wants to become a member of a work group, he has to change himself to conform to the values and norms of that group. If the person is of aggressive type, he may have to become cooperative.

## **Theories of Personality**

### **Trait Theory**

Trait theory presents an approach to understand personality. Many traits are common to most people. However, there are many other traits that are unique to a person. It may be remembered that traits are reactions and not what a person possesses. A person does not possess emotion but he acts emotionally in some circumstances. On the basis of the traits, people may be described as emotional, aggressive, loyal, creative, flexible, humorous, sentimental, and impulsive and so on. Traits are the basic elements of personality and can be used to summarize the behaviour of a person. However, determining basic traits is rather difficult because thousands of descriptive words are there.

## Psychoanalytical Theory

The psychoanalytical theory of personality is based on the Freudian concept of unconscious nature of personality. On the basis of his clinical experience, Freud noted that his patient's behaviour could not always be consciously explained. This prompted him to believe that the personality structure is primarily founded on unconscious framework and that human behaviour and motivation are the outcomes of such conflicting psychoanalytic concepts as the **id**, the **ego** and the **super ego**. **Id** is the foundation of the unconscious and is the basis of libido drives. It strives for sexual and other biological pleasures and has animal instincts of aggression, power and domination. **Ego** is conscious in nature and is a mechanism to relate our conscious urges to the outside real world. It keeps the id in check through the realities of the external environment. While **id** demands immediate pleasure, regardless of costs, **ego** controls it so that these pleasures are granted at an appropriate time and in an acceptable manner. Because of difficulty in keeping the id under control, ego is supported by **super ego**. The super ego is the higher level restraining force and can be described as the conscience of the person. The conscience creates standards of what is right and what is wrong and is generally subconsciously developed by the absorption of cultural and ethical values of the social environment. All these three Freudian elements are inter-related and each cannot exist in isolation from others. In order to create a "normal" personality, there must be a balance in the relationship among these three forces.

## Social Learning Theory

The social learning theory differs from the psychoanalytical theory in two ways. *First*, it is believed that personality development is more a result of social variables than biological drives. *Secondly*, motives can be traced to known and conscious needs and wants rather than unconscious and latent desires. Thus, learning theory looks at personality as the sum total of all that a person has learned. The social learning theory focuses on behaviour patterns and cognitive activities in relation to the specific conditions that evoke maintain or modify them. The social learning theory uses "reinforcement and punishment" approach in understanding personality. For example, good behaviour is rewarded by management in terms of praise that further reinforces good behaviour. Thus, behaviour and

external environment have mutual interaction. Behaviour partly creates the person's environment and the environment affects the behaviour as well.

Learning may also take place simply from observation rather than interaction with the environment. We watch the behaviour of other people, draw conclusions from it and come out with our own behaviour. Unlike trait theory or psychoanalytical theory, social learning theory considers *situation* as an important variable in determining human behaviour.

### **Individual Differences and Impact on Behaviour**

The range of personality traits is quite bewildering. Personality trait means the basic components of personality. The important personality traits that influence employee behaviour at work place are need patterns, locus of control, introversion and extroversion, self-esteem and self-concept, risk taking, self monitoring, Type A or Type B personality, and goal orientation. These are briefly explained below.

#### **Need Patterns**

Primarily four personality needs can be identified that manifest themselves in the work setting. They are the needs for *achievement, affiliation, autonomy, and dominance*. Those with a high need to achieve engage themselves proactively in work behaviours in order to feel proud about their achievements and success. Those who are high in need for affiliation tend to work cooperatively with others. Those who are high in need for autonomy do well when not closely supervised. Those high in their need for dominance prove to be effective in situations where they can enforce their legitimate authority.

#### **Locus of Control**

Locus of control refers to a generalized belief that events are either within one's control (*internal locus of control*) or are determined by the fate or luck (*external locus of control*). People who have moderately strong internal locus of control are likely to perform better at work places. They are likely to be more successful than their external counterparts. Internals are more suitable for leadership positions and are likely to be

more satisfied with the jobs. Internals typically have more control over their own behaviour than externals that leave everything to fate.

### **Introversion and Extroversion**

Personality traits are commonly understood in terms of introversion and extroversion. Introversion is the tendency in individuals which directs them to turn inward and experience and process feelings, thoughts and ideas within themselves. Extroversion refers to the tendency in individuals to turn outward searching for external stimuli with which they can interact. While there is some element of introversion as well as extraversion in all of us, based on dominance, people are regarded as either introverts or extroverts. Extroverts are sociable, lively, gregarious, and seek outward stimuli or external interactions. Introverts are quiet, reflective, introspective, and intellectual people. They interact with a few intimate people. Introverts perform well when they are alone and when the environment is quiet. Since managers have to constantly interact with individuals both within and outside the organization and be able to influence them to achieve organization's goals, it is expected that extroverts prove to be better managers than introverts.

### **Risk - taking**

Personality differences can be seen in the willingness of people to take risk. Some managers are prepared to take risk and act on little information and quickly also. They prove to be as much effective as those other managers that are averse to take risk and make decision cautiously.

### **Self – Monitoring**

It refers to a person's level of sensitivity and ability to adapt to situational cues. High self-monitors change their behaviour quite easily to suit the situation whereas low self monitors reveal their moods and personal characteristics to others who can easily predict their behaviour in a given situation. Self monitoring personality trait is important in carrying out organizational activities. Employees having this trait emerge as better performers, better leaders and are likely to grow faster in the organization.

## **Self – Esteem and Self-Concept**

Self esteem is the result of a person's continuing self-evaluation. Self-esteem refers to the extent to which an individual consistently regards himself as capable, successful, important, and worthy. Self-esteem is an important personality factor that determines how managers perceive themselves and their role in the organization. It is important to self-concept, which refers to the way individuals define themselves as to who they are and derive their sense of identity. High self-esteem leads to a high sense of self-concept, which in turn, reinforces high self-esteem. The two are mutually reinforcing forces. As a trait, a person high in self-esteem is likely to take on more challenging assignments and be successful, thus enhancing their self-concept. That means they define themselves as highly valuable and valued individuals in the organization. The higher the self-concept and self-esteem of a person, the more he contributes to the goals of the organization.

## **Type A and Type B Personalities**

Individuals can be grouped into two types of personalities – Type A and Type B. Type A persons feel a chronic sense of time urgency, are highly achievement oriented, exhibit a competitive drive, and are impatient when their work get slowed down for any reason. In contrast, Type B persons are easy going individuals who neither have sense of time urgency, nor the competitive drive. Type A individuals are more prone to heart attacks than Type B individuals. While helping the organization to move ahead in a relatively short period of time, Type A persons may suffer from health problems which are harmful to themselves apart from the organization.

## **Goal - Orientation**

An important personality difference affecting behaviour at work is goal orientation. There are two orientations – *learning goal orientation and performance goal orientation*. A person with learning orientation develops by acquiring new competencies whereas a person with performance orientation demonstrates competencies by seeking favorable judgments from others. As is well known, some individuals are highly work-oriented while others try to do the minimum that is necessary for not being fired on the job. The extremely work oriented person gets greatly involved in



the job and lives up to being described as “living, eating, and breathing the job”. Estrangement from immediate family members may occur. Though a high level of work orientation of members is good for the organization to achieve its goals, too much of it may lead to premature burnout and health problems.

In the above discussion, it is evident that personality traits are important for employees, managers and organizational effectiveness. With personality differences, we are able to understand, how they affect the behaviour of the people in organizations.

### **Review Questions**

1. Define Personality?
2. How is Personality of an individual shaped?
3. What you know about psychoanalytical theory of personality?
4. Distinguish between introversion and extroversion.

\*\*\*



---

## Lesson - 16 : Motivation

---

### Objectives

*After studying this lesson, you should be able to:*

- Understand The Meaning Of Motivation And Its Importance In ;
- Acquaint With The Various Theories On Motivation; And
- Learn And Practice The Techniques In Your Own Operational Area.

### Lesson Outline

- Needs, Incentives And Motives
- Mcgregor's Participation Model
- Maslow's Need Hierarchy Model
- Herzber's Motivation – Hygiene Model
- Mcclelland's Three Need Model
- Alderfer's Erg Model
- Reinforcement Theory
- Job Enrichment
- Job Enlargement
- Review Questions

Motivation is an effective instrument in the hands of a manager for inspiring the workforce and creating a confidence in doing things effectively. By motivating the workforce, management creates '*will to work*' which is necessary for the achievement of organisational goals. Motivation involves getting the members of the group to perform effectively, to give their loyalty to the group and to carry out properly the purpose of the organisation. The following results may be expected if the employees are properly motivated:

- The employees will cooperate voluntarily with the management and will contribute their maximum towards the goals of the enterprise.
- They will improve the skills and knowledge so that they are able to contribute to the growth of the organisation. This will also result in increased productivity.
- The rates of labour turnover and absenteeism among the workers will be low.
- There will be good human relations in the organisation as friction among the workers and the management will decrease.
- The number of complaints and grievances will come down. Accident rate will also be low.
- Contributes for the improvements in quality of products. Better quality of products will increase the public image of the business.

### **Motivation - Meaning**

The word 'motivation' has been derived from the word 'motive' which means any idea, need or emotion that prompts a man into action. Whatever may be the behaviour of a man, there is some stimulus behind it. Stimulus is dependent upon the motive of the person concerned. Motive can be known by studying his needs and desires. Generally, different motives operate at different times among different people and influence their behaviour. The management should try to understand the motives of individuals which cause different types of behaviour.

Dubin has defined motivation as **“the complex of forces starting and keeping a person at work in an organisation. Motivation is something that moves the person to action, and continues him in the course of action already initiated”**. Motivation refers to the way a person is enthused at work to intensify his desire and willingness to use his energy for the achievement of organisational objectives.

According to Dalton E. McFarland, **“Motivation refers to the way in which urges, drives, aspirations, striving or needs direct, control or explain the behaviour of human beings”**. Motivation has close relationship with the behaviour of human beings. It explains how and why human behaviour is caused. Thus, motivation is a term which applies to the entire class of urges, drives, desires, needs and similar forces.

## Needs, Incentives and Motives

Need is the starting point of motivation. An unsatisfied need creates tension that stimulates drives within the individual. These drives generate a search behaviour to achieve particular goals that will satisfy the need and lead to reduction of tension. The action taken by the individual will lead to reward which satisfies the need and reduces tension.

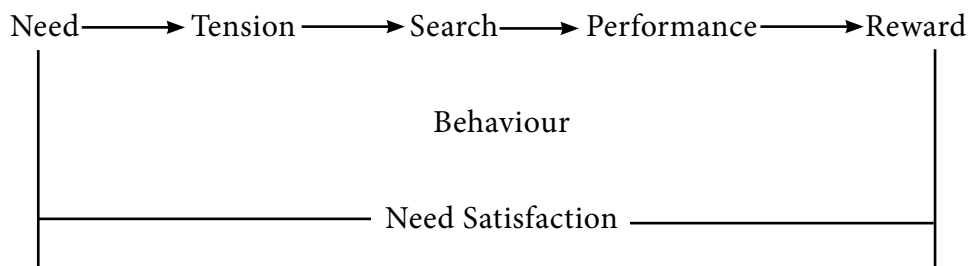

**Figure 16.1: Drivers of Motivation**

Management can do its job effectively only through motivating people to work for the accomplishment of organisational objectives. But, it is difficult to understand motivation without considering what people want and expect from their work.

Human needs may be classified as: (1) basic physiological or primary needs, and (2) social and psychological or secondary needs. Some of the physiological needs are food, water, sleep, air to breathe, sex, clothing and shelter. These needs arise out of the basic physiology of life and are important for the survival of a man. They are virtually universal among people, but they exist in different intensity. Needs are also influenced by the social environment. One man may require wheat to satisfy his hunger, other may require rice for the same purpose.

Secondary needs are related to mind and spirit rather than to the physiology of life. Many of these needs develop as one matures. Instances are belongingness, recognition, self-esteem, sense of duty, self-assertion and so on. Actually, these are the needs which complicate the efforts of managers because the secondary needs vary among people much more than primary physiological or basic needs.

## **Motivational Sources**

Having understood the concept of motivation, now let us understand the various sources of motivation. You may note that motivation may sometimes come from external environment in the form of rewards or punishments and sometimes it is generated from within an employee in the form of intrinsic motivation. It may be recognized that under the same set of external factors, all employees are not equally motivated. It depends upon various factors which you can understand when you go through the different motivational theories. The motivational sources are explained below.

### **Positive vs. Negative Motivation**

Motivation may be either positive or negative. *Positive motivation* takes place when management recognizes the employee's efforts towards the achievement of organizational goals. It is positive because, this kind of motivation increases the level of performance, promotes team spirit, a sense of cooperation and generates a feeling of belongingness and happiness. The positive motivational factors are:

- Praise and reward for good performance.
- Concern for the well being of an employee.
- Confidence reposed in the employee.
- Delegation of authority
- Scope of participation given in the decision making.

*Negative motivation*, on the other hand, results from the use of force, pressure, fear or threat. You may note that fear of punishment also affects motivation and thereby the behaviour of a person. In the organizations, negative motivation may come from the fear of being transferred, demoted or removed. This fear of punishment prompts the person to work hard and achieve the goals. It may, however, be realized that negative motivation is not desirable because employees do not like to be punished. Hence, it is desirable to motivate the employees by positive means.

## **Extrinsic Vs. Intrinsic Motivation**

Motivation may be either extrinsic or intrinsic. *Extrinsic motivation* is induced by external factors primarily financial rewards. It is expected that the behaviour caused by positive rewards is likely to be repeated. But the reward should be sufficiently powerful for desirable behaviour to be repeated. Money acts as a significant incentive for positive behaviour of employees. Realizing the value of financial incentives as motivators, managements now-a-days make use of wage increments, bonus payment, fringe benefits, stock options, profit sharing schemes, paid holidays, medical benefits, etc. for motivating the employees.

*Intrinsic motivation* is something that is generated within an individual. It is an inner feeling. It may be a sense of achievement or recognition leading to satisfaction that motivates the employee further. Since this kind of motivation comes from within, it is called intrinsic motivation. There are many retired doctors who work free in the hospitals because it gives them a sense of accomplishment and satisfaction. Some of the intrinsic motivators include praise, status, recognition, esteem, challenge, risk and responsibility in job.

## **Mc GREGOR'S PARTICIPATION MODEL**

It was McGregor who set forth – at opposite extremes – two pairs of assumptions about human beings which he thought were implied by the actions of autocratic and permissive managers. First set of assumptions are known as “Theory X” and the second set of assumption are known as “Theory Y”. It is important to note that these sets of assumptions are not based on any empirical research. They, according to McGregor, are intuitive deductions.

### **Theory X**

**Managers with Theory X orientation make the following assumptions about people:**

- Average human being has an inherent dislike for work and will avoid it, if he can.
- The average human being is lazy and avoids responsibility.

- The average human being is indifferent to organisational goals.
- The average human being prefers to be directed, wishes to avoid responsibility, has relatively little ambition and wants security above all.

According to McGregor, this is a traditional theory where workers have to be persuaded and pushed into performance. Management can offer rewards to a worker who shows higher productivity and can punish him if performance is below standard. This is also called '*carrot and stick*' approach to motivation. It suggests that threats of punishments and strict control are ways to control the people.

### **Theory Y**

Managers with Theory Y orientation make the following assumptions about people:

- The average human being does not inherently dislike work. Depending upon controllable conditions, work may be a source of satisfaction or a source of punishment.
- The average human being will exercise self direction and self-control in the service of objectives to which he is committed.
- Commitment to objectives is a function of the rewards associated with their achievement.
- The average human being learns under proper conditions, not only to accept, but also to seek responsibility.
- The capacity to exercise a relatively high degree of imagination, ingenuity and creativity in the solution of organisational problems is widely, not narrowly, distributed in the population.

Theory Y assumes that goals of the organisation and those of the individuals are not necessarily incongruent. Worker's commitment is directly related to the satisfaction to their needs. Thus, this theory places great emphasis on satisfaction of the needs, particularly the higher ones of the employees. It does not rely heavily on the use of authority as an instrument of command and control. It assumes that employees exercise self-direction and self-control in the direction of the goals to which they feel themselves committed.



## **Application of Theory X and Theory Y**

Theory X and Theory Y are important tools in understanding the behaviour of human beings and in designing the incentive schemes to motivate the employees. Neither of the two sets of assumptions is applicable fully in all situations and to all types of people. It appears that Theory X is more applicable to unskilled and uneducated lower level workers who work for the satisfaction of their basic needs of food, clothing and shelter. Theory Y appears to be more applicable to educated, skilled and professional employees who understand their responsibility and are self-controlled. However, there can be exceptions. A lower-level employee may be more responsible and mature than a well-qualified higher level employee. The examples of employees at higher levels in modern organisations shirking responsibility are not uncommon. Therefore, management should use an amalgamation of both the theories to motivate different types of employees.

## **Theories of Motivation**

There are two types of motivational theories - content theories and process theories (cognitive theories). While content theories explain what motivates and what does not motivate, the process theories examine the variables that go into the motivational process taking place within an individual. Some of these theories are explained below.

### **Maslow's Need Hierarchy Theory**

Abraham Maslow has propounded this need hierarchy theory as early as in 1943. Maslow points out that human beings have divergent needs and they strive to fulfill those needs. The behaviour of an individual is determined by such needs. These needs range from biological needs at lower level to psychological needs at the highest level. Further, these needs arise in an order of hierarchy or priority such that lower level needs must be satisfied before higher level needs become important for motivation. Maslow postulates five basic needs arranged in an hierarchical fashion as follows:

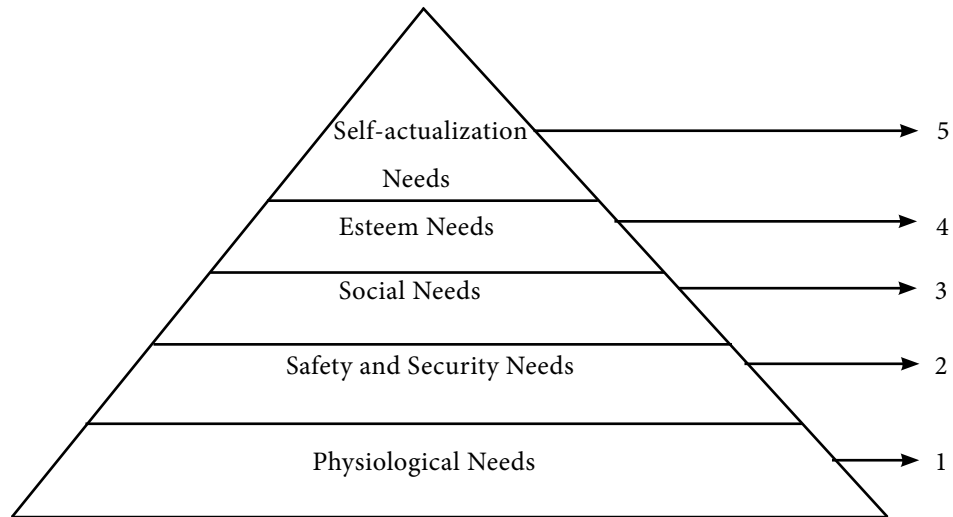

**Figure 16.2: Maslow's Hierarchy Needs**

The first three levels of needs at the bottom are known as lower order needs as they are related to one's existence and security. The top two levels of needs are called higher order needs as they are concerned with personal development and realization of one's potential. The needs are explained below.

### **Physiological Needs**

The physiological needs are the basic needs having the highest strength in terms of motivation. These are the needs arising out of biological tensions created as a result of deprivation of food, water, shelter, rest, etc. If these basic needs are gratified, then the next level needs become important and act as motivators.

### **Safety and Security Needs**

Once the physiological needs are fulfilled, safety and security needs become predominant. These are the needs for self-preservation while physiological needs are for survival. These needs include security, stability, freedom from anxiety and a structured and ordered environment. Safety and security needs arise out of the concern for the fulfillment of physiological needs in the future. An individual seeks economic or social protection against future threats and dangers that he is exposed to. If once these needs are gratified, they fail to serve as motivators any more. The individual, then, moves on to the next level needs and strives for their fulfillment.

## **Social Needs**

At the third level, social needs or love needs become important. An individual cannot live an isolated life. A sense of affiliation becomes important for a meaningful life. These needs include the need for love, affection, companionship and social interaction. We know very well that at home the child needs the love of parents and at school he needs the friendship of his classmates.

This is to attain recognition from others which would induce a feeling of self-worth and self-confidence in the individual. It is an urge for status, prestige and power. Self-respect is the internal recognition while respect from others is the external recognition. People who are able to fulfill this need feel that they are useful and have some positive influence on their surrounding environment.

## **Self-actualization Needs**

At the highest level is the need to develop and realize one's capacities and potentialities to the fullest extent possible. This need gets activated as motivator when all other needs have been reasonably fulfilled. At this level, the person wants to excel in the skills and abilities that he is endowed with. As a result, he seeks challenging work assignments that require creativity and talent. This need is inner-oriented and the motivation is intrinsic in nature. A self-actualizing person is creative, independent, content, and spontaneous and has a good perception of reality. He constantly endeavors to realize his full potential.

In conclusion, it may be said that Maslow's model explains human behaviour in general. It has nothing to do with the employee motivation at the work place. Further, human needs may not necessarily have the hierarchy as shown by him. The relative dominance of not able to satisfy the social needs may prompt a person to set the physiological needs and safety needs aside and motivate him for earning the love and affection of the family members and the friendship of his colleagues.

Maslow felt that the human needs have a definite sequence of domination. Second need does not dominate until first need is reasonably satisfied and third does not dominate until first two needs have been reasonably satisfied and so on. The other side of the need hierarchy is that

man is a wanting animal, he continues to want something or the other. He is never fully satisfied, the other need arises. As said above (according to Maslow), needs arise in a certain order of preference and not randomly. Thus, if one's lower level needs (physiological and security needs) are unsatisfied, he can be motivated only by satisfying his lower level needs and not satisfying his higher level needs. Another point to note is that ***once a need or a certain order of needs is satisfied, it ceases to be a motivating factor.*** Man lives for bread alone as long as it is not available. In the absence of air one can't live, but there is plenty of air which ceases to be motivating.

The physiological and security needs are finite, but the needs of higher order are sufficiently infinite and are likely to be dominant in persons at higher levels in the organisation. This has been proved by various studies. A study by Boris Blai supported this by showing that managers and professionals in U.S.A. highly value self-realisation, while service and manual workers in India reported that they give to priority to job security, earnings and personal benefits all lower order needs.

### **Appraisal of Need Hierarchy Model**

The need priority model may not apply at all times in all places. Surveys in European countries and Japan have shown that the model does not apply very well to their managers. Their degree of satisfaction of needs does not vary according to the need priority model. For example, workers in Spain and Belgium felt that their esteem needs are better satisfied than their security and social needs. Apparently, cultural differences are an important cause of these differences. Thus, need hierarchy may not follow the sequence postulated by Maslow.

Another important proposition that one need is satisfied at one time is also a doubtful validity. Man's behaviour at any time mostly guided by multiplicity of motives. However, one or two motives in any situation may be more dominant, while others may be of secondary importance.

There are always some people in whom, for instance, need for self-esteem seems to be more prominent than that of love. There are also creative people in whom the drive for creativeness seems to be more important. In certain people, the level of operation may be permanently

lower. For instance, a person who has experienced chronic unemployment may continue to be satisfied for the rest of his life if only he can get enough food.

### **HERZBERG'S Two Factor theory of MOTIVATION**

A significant development in motivation theory was distinction between motivational and maintenance factors in job situation. A research was conducted by Herzberg and his associates based on the interview of 200 engineers and accountants who worked for eleven different firms in Pittsburgh area. These men were asked to recall specific incidents in their experience which made them feel particularly bad about jobs. The findings of the research led to draw a distinction between what are called as '**motivators**' and '**hygiene factors**'. To this group of engineers and accountants, the real motivators were opportunities to gain expertise and to handle more demanding assignments. Hygiene factors served to prevent loss of money and efficiency. *Thus, hygiene factors provide no motivation to the employees, but the absence of these factors serves as dissatisfies.*

Some job conditions operate primarily to dissatisfy employees. Their presence does not motivate employees in a strong way. Many of these factors are traditionally perceived by management as motivators, but the factors are really more potent as dissatisfiers. They are called maintenance factors in job because they are necessary to maintain a reasonable level of satisfaction among the employees. Their absence proves to be strong dissatisfiers. They are also known as '*dissatisfiers*' or '*hygienic factors*' because they support employees' mental health. Another set of job conditions operates primarily to build strong motivation and high job satisfaction among the employees. These conditions are 'Motivational Factors'. Herzberg's maintenance and motivational factors have been shown in the table given below.

## Herzberg's Maintenance and Motivational Factors

Maintenance or Hygienic Factors	Motivational Factors
<ol style="list-style-type: none"> <li>1. Company Policy.</li> <li>2. Technical Supervision.</li> <li>3. Inter-personal relations with Supervisor.</li> <li>4. Inter-personal relations with Peers.</li> <li>5. Inter-personal relations with Subordinates.</li> <li>6. Salary.</li> <li>7. Job Security.</li> <li>8. Personal life.</li> <li>9. Working conditions.</li> <li>10. Status.</li> </ol>	<ol style="list-style-type: none"> <li>1. Achievement, Administration.</li> <li>2. Recognition.</li> <li>3. Advancement.</li> <li>4. Possibility of growth</li> <li>5. Responsibility.</li> </ol>

Hygienic factors include such things as wages, fringe benefits, Physical conditions and overall company policy and administration. The presence of these factors at a satisfactory level prevents job dissatisfaction, but they do not provide motivation to the employees. So they are not considered as motivational factors, on the other hand, are essential for increasing the productivity of the employees. They are also known as satisfiers and include such factors as recognition, feeling of accomplishment and achievement, opportunity of advancement and potential for personal growth, responsibility and sense of job and individual importance, new experience and challenging work etc.

### Comparison of Herzberg and Maslow Models

In fact, there is a great similarity between Herzberg's and Maslow's models. A close examination of Herzberg's model indicates that some employees may have achieved a level of social and economic progress in the society and for them higher level needs of Maslow (esteem and self-actualization) are the primary motivators. However, they still must satisfy the lower level needs for the maintenance of their current state. Thus, we can say that money might still be a motivator for operative employees and

for some managerial employees. Herzberg’s model adds to the Maslow’s need hierarchy model because it draws a distinction between the two groups of factors, namely, motivational and maintenance, and points out that the motivational factors are often derived from the job itself. Most of the maintenance factors come under comparatively lower order needs. In economically advanced countries, such needs of the employees are fulfilled and hence cease to be motivators.

As shown in the following diagram Maslow’s Physiological, security and social needs come under Herzberg’s maintenance factors whereas self-fulfillment comes under motivating factors. It may further be noted that a part of esteem need comes under maintenance factor and another under motivational factors. The esteem needs are divided because there are some distinct differences between status per se and recognition. Status tends to be a function of position one occupies. This position may be gained through family ties or social pressures and so this may not be a reflection of personal achievement or recognition. Recognition is gained through competence and achievement. It is earned and granted by others. That is why status is classified with physiological, safety and social needs as a hygiene factor, while recognition is classified with esteem as a motivator.

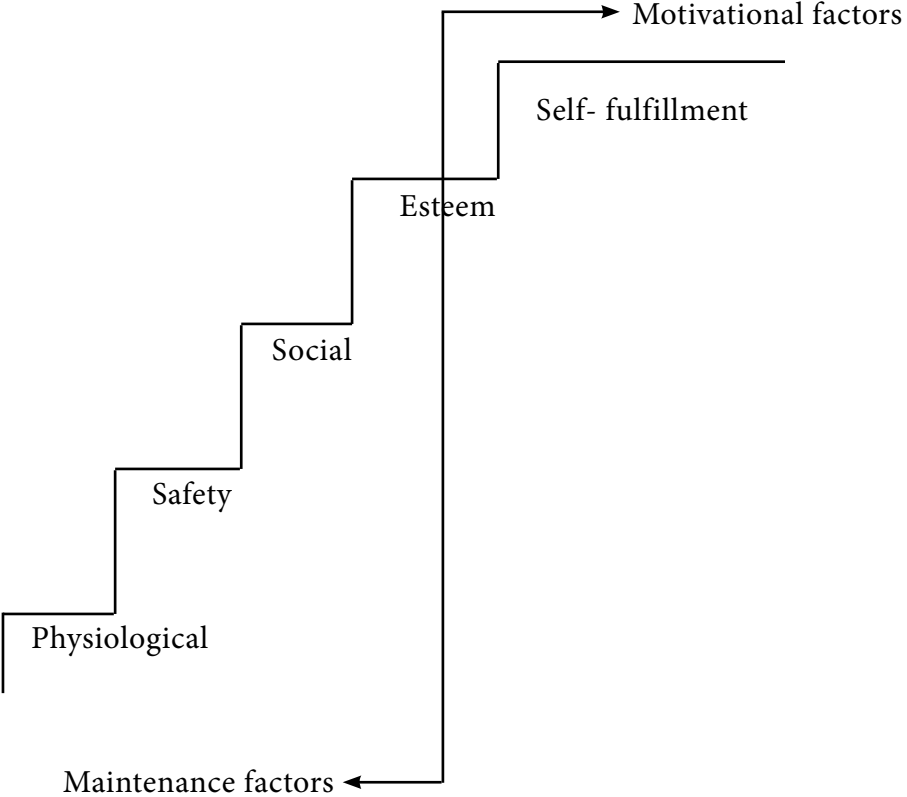

**Figure 16.3: Relationship between Maslow’s and Herzberg**

## **David Mc Clelland's Three Need Model**

David McClelland gave a model of motivation which is based on three types of needs achievement, power and affiliation. They are stated below:

- (i) Need for achievement (n Ach): a drive to excel, advance and grow
- (ii) Need for power (n Pow): a drive to influence others and situations
- (iii) Need for affiliation (n Aff): a drive for friendly and close interpersonal relationships.

### **Achievement Motivation**

Some people have a compelling drive to succeed and they strive for personal achievement rather than the rewards of success. This drive is called the need for achievement (n ach). Based on his extensive research into the achievement need, McClelland found that high achievers differentiate themselves from others by their desire to do things better. They seek situations where they can attain personal responsibility for finding solutions to problems, where they can receive rapid feedback on their performance so they can set moderately challenging goals. High achievers are not gamblers; they dislike succeeding by chance. They prefer the challenge of working at a problem and accepting the personal responsibility for success or failure, rather than leaving the outcome to chance or the actions of others.

### **Power Motivation**

The need for power (n pow) is a drive to have impact, to be influential and to control others. Individuals high in n pow enjoy being “in charge”, strive for influence over others, prefer to be placed into competitive and status oriented situations, and tend to be more concerned with gaining influence over others than with effective performance. Power-motivated people wish to create an impact on their organisations and are willing to take risks to do so.



## **Affiliation Motivation**

This need has received the least attention of the researchers. Affiliation need (nAff) can be viewed as the desire to be liked and accepted by others. It is the drive to relate to people on a social basis. Individuals with a high affiliation motive strive for friendship, prefer cooperative situations rather than competitive ones, and desire relationship involving a high degree of mutual understanding.

People possess the above needs in varying degrees. However, one of the three needs will tend to be more characteristic of the individual. Individuals with a high need for achievement thrive on jobs and projects that tax their skills and abilities. Such individuals are goal-oriented in their activities, seek challenge and want task relevant feedback. Individuals with high power seek to dominate, influence or have control over others. McClelland's research revealed that managers generally score high on the need for achievement. In other words, motivating forces for managers lie in the challenge and potential of the job.

## **Alderfer's Existence-Relatedness – Growth (Erg) Model**

Serious doubts have been expressed about the existence of the five distinct need categories which Maslow hypothesized. There seems to be some over-lapping between the security, social and physiological need. Also, the lines between esteem, social and self-actualization needs are not entirely clear. With these points in mind, Clayton Alderfer condensed Maslow's need categories into three sets:

- **Existence needs.** These include all forms of materials and Physiological and safety needs, i.e., Maslow's first two levels of needs.
- **Relatedness needs.** These include all needs that involve relationships with other people we care about. The examples include anger and hostility as well as friendship. Thus, the opposite of satisfaction of relatedness needs is emotional distance rather than hatred. Relatedness needs cover Maslow's social needs and that of esteem needs which are derived from other people.
- **Growth needs** – These needs involve persons making creative efforts to achieve full potential in the existing environment. It is like Maslow's highest level need of self-actualization.

Alderfer also revised Maslow's theory in three other ways:

1. He argued that the three need categories form a hierarchy only in the sense of decreasing concretions. That is, as we move from a focus on the existence to relatedness to growth needs, the ways can satisfy those needs become increasingly abstract.
2. He recognized that rise in the level of satisfaction of our existence and relatedness needs may result in decrease in their importance to us. Growth needs become more important as we successfully satisfy them. That is, as we are able to be productive and creative, we look to higher goals and, in so doing, are again dissatisfied.
3. He reasoned that we are likely to try to first satisfy the most concrete needs and then to move on to more abstract needs. In this sense, Alderfer sounds somewhat like Maslow, suggesting a pattern of satisfaction progression- that is, as one need is satisfied, we progress to next higher need.

Alderfer conceived ERG needs along a continuum which avoids the implication that the higher up an individual is in the hierarchy the better it is. Different types of needs can operate simultaneously. If a particular path towards the satisfaction is blocked, the individual will both persist along that path and at the same time regress towards more easily satisfied needs. In this way, Alderfer distinguishes between chronic needs which persist over a period of time and the episode needs which are situational and can change according to the environment.

## **Reinforcement Theory**

Reinforcement theory is based on the concepts of operant conditioning developed initially by the well-known psychologist B.F. Skinner. Reinforcement theory argues that the **behavior of people is largely determined by its consequences**. In other words, those actions that tend to have positive or pleasant consequences tend to be repeated more often in the future, while those actions that tend to have negative or unpleasant consequences are less likely to be repeated again. The reinforcement theory suggests that managers should try to structure the contingencies of rewards and punishments on the job in such a way that the consequences of effective job behaviour are positive while the consequences of ineffective work behaviour are negative or unpleasant. The focus of this approach is

upon changing or modifying the behaviour of people on the job. That is why it is also labeled as organizational behaviour modification.

The basic notion underlying reinforcement theory is concept of reinforcement itself. An event is said to be **reinforcing if the event** following some behaviour makes the behaviour more likely to occur again in the future. It involves the use of four strategies to systematically reinforce and are discussed as under:

(i) **Positive Reinforcement:** It entails the use of rewards (or other positive consequences) that stimulates desired behaviour and strengthens the probability of repeating such behaviour in the future. Positive reinforcers can be money, praise, promotion, recognition, etc.

(ii) **Negative Reinforcement:** This strategy also called “avoidance learning”. It implies the use of unpleasant consequences to condition individuals to avoid behaving in undesirable ways. By making unpleasant consequences contingent on undesirable behaviour, individuals learn to systematically change patterns of behaviour. In work environments, training, safety warnings, orientation sessions and counseling help alert employees against negative consequences of undesirable behaviour.

(iii) **Extinction:** There is withdrawal of all forms of reinforcement to remove undesirable behaviour. For instance, a disruptive employee who is punished by his supervisor for his undesirable behaviour may continue the disruptions because of the attention they bring. By ignoring or isolating the disruptive employee, attention is withheld and possibly also the motivation for fighting.

(iv) **Punishment:** This tool is used when an unpleasant or undesirable behaviour needs to be reduced or eliminated. For example, a worker’s wages may be deducted if the quality of goods produced is of substandard quality.

## **Financial and Non-Financial Incentives**

The term ‘incentives’ means an inducement which arouses or stimulates one to action in a desired direction. An incentive has a

motivational power; it influences the decisions of individuals on putting in necessary effort towards task performance. In modern organizations, a large variety of incentives are used to motivate the people. These incentives may be broadly grouped into: *(i) financial or pecuniary incentives, and (ii) non-financial incentives.*

The financial incentives may be distinguished from the non-financial incentives on the following grounds:

1. Financial or monetary incentives are meant to satisfy those which money can buy. The needs for food, clothing, and shelter can be fully satisfied by money, but the needs for security, social affiliation and status can be partially satisfied by money. But non-pecuniary incentives are meant for satisfaction of those needs which can't be satisfied by money. The examples are higher level needs such as status, ego, sense of responsibility, career advancement, autonomy.
2. Financial incentives are tangible, i.e. visible and measurable; they have a direct effect on the organization and the members. But non-financial incentives are intangible and they have an indirect influence on the organization and the members.
3. Financial incentives are determined by reference to several factors such as job evaluation, cost of living trends, fringe benefits offered by competitors, agreement between the employers and employees, etc. Non-financial incentives are based on the nature of jobs, strength of aspirations and urges of employees and behavioural orientation of management.
4. Financial incentives are generally used to motivate workers and other non-managerial employees. But non-financial incentives are used to motivate managerial and other higher level personnel. They are also used to supplement and support the pecuniary incentives in the organization.

### **Role of Non-Financial Incentives**

Financial incentives do not work for ever to motivate the people at work. As a matter of fact, when the physiological and security needs

are fulfilled with the help of money, money ceases to be the motivating force; it becomes the maintenance factor as said by Herzberg. Therefore, employees do not always run after money. They have other needs also. They want status and recognition in the society, they want to satisfy egoistic needs and they want to achieve something in their lives. In order to motivate the employees having these needs, management can take the help of following non-financial incentives:

1. **Praise:** Praise satisfies one's ego needs. Sometimes, praise is more effective than another incentive. We have seen that in industry, at home or elsewhere, people respond better to praise. However, this incentive should be used with greater degree of care because praising an incompetent employee would create resentment among competent employees. Of course, occasionally, a pat on the back of an incompetent employee may act as incentive to him for improvement.
2. **Competition:** Competition is a kind of non-financial incentive. If there is a healthy competition among the individual employees or groups of employees, it will lead them to achieve their personal or group goals in a better way.
3. **Opportunity for Growth:** Opportunity for growth is another kind of incentive. If the employees are provided opportunities for their advancement and growth and to develop their personality, they feel very much satisfied and become more committed to the organization and become more committed to the organizational goals.
4. **Feedback:** Knowledge of the results/performance leads to employee satisfaction. A worker likes to know the result of his performance. He gets satisfaction when his superior appreciates the work he has done.
5. **Worker's participation in Management:** Employees participation in management provides an important incentive to the employees. It gives them psychological satisfaction that their voice is being heard.
6. **Suggestion System:** Suggestion system is an incentive which satisfies many needs of the employees. Many organizations which use the suggestion system make use of cash awards for useful suggestions.

They, sometimes, publish the worker's name with his photograph in the company's inhouse magazines/reports/brochures. This motivates the employees to be in search for something which may be of greater use to the organization.

### **Review Questions**

1. 'Motivation is the core of management'. Comment. What practical suggestions would you offer to management to motivate its staff in an industrial organization?
2. Explain Maslow's need hierarchy. Is this hierarchy rigid? Discuss with suitable examples.
3. Explain Herzberg's Two Factor Theory and differentiate it from Maslow's Theory of Need Hierarchy?
4. List out the assumptions of McGregor's Theory X and Theory Y. Which one is applicable in India?
5. "Motivation is based on rewards". Explain the statement and discuss various types of motivators.
6. "Money holds the key to work motivation in modern business organizations." Discuss and give also the role of non-financial incentives in motivation.
7. "Non-financial incentives are as strong motivators as the financial ones". Critically examine this statement in the light of Maslow's and Herzberg's theories of motivation.

which they welcome and accept the managerial philosophy is very crucial to the development of sound and favorable organizational climate. The climate is said to be highly favorable when the existing management techniques are such that employees goals are perfectly matched to the ideas of organizations.

**Structure:** Structure is the framework that establishes formal relationship and delineates authority and functional responsibility. It is generally believed that decentralized structure results in sound climate. In sharp contrast, if the management feels the necessity of maintaining greater degree of consistency in operations regarding decision-making, it will be wedded to centralized structure.

**Process:** In every organization certain processes are vital so that it functions. Communication, decision making, motivation and leadership are some of the important processes through which management achieves the tasks. For instance, if we consider leader-follower relationship, leadership process, it is leader's choice whether to allow subordinates in decision-making,

give assignments, etc. A leader has to be aware of the possible influence of his actions on the climate while deciding about the most appropriate supervisory technique for a given situation. It should be noted that failure to give consideration to the effect on climate could cause great harm to the organization.

**Physical Environment:** the external conditions of environment, the size, location of the work place etc., will also affect organizational climate. An employee performing his job in relatively clean, quiet, safe environment will undoubtedly have a favorable perception of the organizational climate. Noise has also been considered instrumental in influencing the climate of an organizational.

**System Values and Norms:** Every organization has discernible and fairly formal value system where certain kinds of behaviors are rewarded and encouraged and certain kinds of behavior forces an individual to formal sanctions. The formal value system is communicated to employees through rules, regulations and policies. But informal value system is very difficult to ascertain. But both exert influence on organizational climate.

In general, organisational climate provides certain stimuli, offers certain opportunities and raises certain expectations among its members; at the same time, it also creates certain constraints, threats, problems and frustrations. Organisational climate influences the perceived ability of the individual employee, which in turn has a decisive effect on his motivation. Perceived ability is influenced by the nature and clarity of the job, the scope of responsibility, degree of freedom, supervisory support and training, safety and other physical working conditions, previous experience and so on.

## **Organizational Culture**

Organizational culture is the set of assumptions, beliefs, values and norms that are shared by the members of an organization. It may be consciously created by its key members, or it may have simply evolved over time. It represents a key element of the work environment in which employees perform their jobs. A culture may exist across an entire organization, or it may refer to the environment within a single division, branch, plant, or department. The idea of organizational culture is somewhat intangible, for we cannot see it or touch it, but it is present and pervasive. Like the air in a room, it surrounds and affects everything that happens in an organization. Because it is a dynamic systems concept, culture is also affected by almost everything that occurs within an organization. They give an organizational identity to employees – a defining vision of what the organization represents. They are also an important source of stability and continuity to the organization which provides a sense of security to its members.

## **Characteristics of Cultures**

Each organization has its own history, patterns of communication, systems and procedures, mission statements and visions, stories and myths which, in their totality, constitute its distinctive culture. Cultures are also relatively stable in nature. Most organizational cultures have historically been rather implicit rather than explicit. A defining characteristic of most culture is that they are seen as symbolic representations of underlying beliefs and values.

## **Measuring Organizational Culture**

Systematic measurement and comparison of cultures is difficult. Most of the early attempts by researchers relied on examination of stories, symbols, rituals, and ceremonies to obtain clues. Others have used interviews and open ended questionnaires in an attempt to assess employee values and beliefs. In some cases, examination of corporate philosophy statements has provided insights into the espoused cultures (the beliefs and values that the organizations state publicly). Another approach is to survey employees directly and seek their perceptions of the organization's culture. Another interesting method is to become a member of the organization and engage in participant observation.

## **Characteristics of organizational cultures**

- Distinctive
- Stable
- Implicit
- Symbolic
- Integrated
- Accepted
- A reflection of top management

## **Communicating Culture**

If organizations are to consciously create and manage their cultures, they must be able to communicate them to employees, especially the newly hired ones. Individuals are generally more willing to adapt when they want to please others, gain approval, and learn about their new work environment. These cultural communication acts may be lumped under the umbrella of organizational socialization, which is the continuous process of transmitting key elements of an organization's culture to its employees. Individualization occurs when employees successfully exert influence on the social system around them at work by challenging the culture or deviating from it.



## Review Questions

1. Describe the organisational culture that seems to exist in your organisation. What are some of the implicit or explicit norms, values and assumptions?
2. Discuss the bases or forms of departmentalisation in an organisation?
3. Explain various characteristics of Organisational Climate.
4. Distinguish between
  - a. Horizontal & Vertical dimension of organisational structure.
  - b. Commercial & Non – Commercial dimension of organisational structure.
  - c. Traditional & Modern dimension of organisational structure.
5. What are the major dimensions of organisational structure?
6. Describe the factors determining organisational structure.

\*\*\*



---

## Lesson - 17 : Values And Attitudes

---

### Objectives

*After going through this lesson, you should be able to:*

- Understand The Meaning And Types Of Values;
- Familiarize With The Changing Value System At Work Place;
- Know The Attitudes And The Formation Of Attitudes; And
- Appreciate The Implications Of Attitudes In Organizations.

### Lesson Outline

- Importance, Sources & Types Of Values
- Values At Workplace
- Attitudes And Their Formation
- Types Of Attitudes
- Implications Of Attitudes
- Review Questions

At the outset, let us examine a few definitions of values. According to Rokeach “values represent basic conviction that a specific mode of conduct or end state of existence is personally or socially preferable to an opposite or converse mode of conduct or end state of existence”. Chakravarti defines values as “the manner in which an individual tends to make judgements or choices, both about goals and means, at different stages of one’s life, in different facets of it, as are deemed to lead to the well being and happiness of oneself and society”.

From the above, we understand that values are learnt from the society and hence are acceptable to the society as preferred ‘modes of conduct’ or ‘end states’. Values are stable and long-lasting beliefs about what is important in a variety of situations. They are evaluative standards that help us distinguish between right and wrong or good and bad in the world. Values do not represent what we need but they indicate what we

ought to do to achieve the need in a socially desirable way. Some people value practicality while others value aesthetics. Some people value frugality while others value generosity. Values influence our priorities, preferences and our actions. Value systems represent prioritizing of individual values in relation to their relative importance. We all have a set of values that form a value system. This system is identified by the relative importance assigned to such values as pleasure, self-respect, honesty, freedom, equality, and so on. Consequently, values of an individual influence his attitudes and also his behaviour.

### **Importance of Values**

In the organisational context, values are important because they influence employee conduct and behaviour. They play a vital role in behavioural disposition and the decision making behaviour of an individual. Now-a-days, employees resent the traditional command-and-control supervision and expect a lot of autonomy and operational freedom. Organizational ethics is becoming important in view of the manipulations and malpractices indulged in at various levels in the organization. It has something to do with the values of that organization.

Values influence behaviour of an employee in several ways. If an employee feels that payment of wages on the basis of performance is right, he / she cannot accept payment of wages on the basis of seniority, he becomes indifferent to such a system followed in the organization. Therefore, the values of individuals need to be studied, so that employees' values could be matched with that of the organization.

### **Sources of Values**

Values are learnt right from the childhood. They are taught by mother when she guides the child in several ways like “you go to bed early”, “you should wear clean clothes”, “you should achieve first rank” and things like that. Early ideas of what is right and wrong were probably formulated from the views expressed by the parents. As one grows, there is a likelihood of getting exposed to other value systems and be induced by them. We derive the values from the people we love or respect like our parents, teachers, friends, and other famous celebrities in movies, sports, business, and politics. Out of our admiration for them, we are likely to

emulate them by imbibing their values also.

You may remember that in our culture itself, certain values have been developed over time and they are continuously reinforced. Peace, cooperation, harmony, equity, and democracy are the desirable societal values nurtured in our culture.

It is interesting to know that values are relatively stable and enduring. This is because of the way in which they are originally learned. In childhood, you are told that a certain behavior is always desirable or always undesirable. You are told, for example, that you should be honest and truthful. It is this absolute learning of values which ensures their stability and endurance. You may also note that values of an individual do change, but change very slowly. The process of questioning our values may lead to change in the existing values system.

## **Types of Values**

You may note that values do not operate in isolation. Several values interact with each other to form value system in a society. According to Rokeach, value systems are composed of rank-ordered sets of values that fall into two general categories namely *terminal values* and *instrumental values*. Terminal values reflect the desired end states of existence whereas instrumental values are related to the choice of behaviour in reaching those end states. Terminal values are desired states of existence that we try to achieve. Preferences like duty, equality and wisdom and a compatible life are some of the terminal values. On the other hand, instrumental values are desirable modes of behaviour that help us reach terminal values. Being polite, courageous, logical, self controlled, ambitious etc., are some of the instrumental values.

Values can be categorized on the basis of the level at which they operate. These may be:

- *Personal values* which are formed from past experience and interaction with others;
- *Cultural values* which are the dominant beliefs held collectively society;
- *Organizational values* which are at the heart of organizational culture in terms of shared assumptions, values and beliefs; and
- *Professional values* which are held by the members of an occupational group.

Values may also be classified as the *espoused values* and *enacted values*. Espoused values represent the values that we want other to believe we avoid by. Values are socially desirable and so people create a positive public image by claiming to believe in values that others expect them to hold. Contrary to this, enacted values represent the values actually practiced. These values, in fact, guide our decisions and behaviours.

It may be recognized that values are functions of preferences. The most important early work in categorizing values was done by Allport and his associates. They identified six types of values. They are:

1. *Theoretical*-places high importance on the discovery of truth through a critical and rational approach.
2. *Economic*-emphasizes the usefulness and practicability.
3. *Aesthetic*-places the highest value on form and harmony.
4. *Social*-the highest value is given to the love of people.
5. *Political*-places emphasis on acquisition of power and influence.
6. *Religious*-concerned with the unity of experience and understanding of the cosmos as a whole.

Allport and his associates developed a questionnaire that describes a number of different situations and asked respondents to rank fixed set of answers. Based on the respondents' replies, the researchers could rank individuals in terms of the importance they give to each of the six types of values. The result is a value system for a specific individual.

### **Values at Workplace**

The values at work place may be defined as the perception of what is preferable from among the alternative modes of conduct or end states with respect to one's work. Work values are expected to be an integral part a nation's cultural system and hence we notice differences between the work values of American organizations and Japanese organizations. They represent the values internalized by members of the society through the process of socialization. In global organizations, now-a-days, it is becoming difficult to achieve congruence between the diverse values of employees and those of the organization.

While defining managerial values, Indian executives mentioned work ethics, commitment, self-motivation, integrity, hard work, character

etc. It is reported in a study that the most important goals of an ethical Indian manager are customer satisfaction, achievement of organizational goals within scheduled time, employee motivation and career progress. According to Upadhyay, Indian managers are status and power oriented and considers decision making as their prerogative and consultation as a means of eroding their authority. They tend to take credit for work done by them rather than share it with individual members of the team. It may be noted that while values are stable and enduring, they are not rigid. Therefore, new generations of employees may bring into the organizations new set of values.

In some of the studies age has been found to be a major factor in differentiating employee values. Young employees give importance to more autonomy at work place, instant gratification, quick growth, individualism, and openness compared to older employees.

As a result, young employees bring a different set of values to the work place. Hence, management should understand those new values and accordingly deal with them for good performance. Managers have to study values because they are the foundations for understanding a person's attitudes, perceptions, motivation and behaviour in the organization.

### **Attitudes and their Formation**

Having understood the values, let us try to understand the attitudes and their formation. You should recognize that attitudes are evaluative statements- favorable or unfavorable- concerning objects, people, or events. They indicate how one feels about something. When you say "*I like my job,*" or "*I hate telling lies*" they represent your attitudes.

Attitudes are different from values. Values could be a little broader in concept while attitudes are more specific. Values indicate the rightness or desirability of something. For example, a statement like "*gender discrimination is bad*" reflects the values one stands for. On the other hand, a statement "*I prefer women to be given an equal place with men in recruitment*" represents the attitude of a person. Attitudes are learned predispositions towards various aspects of our environment.

While, attitudes and values are different, there are also some similarities. Both are powerful instruments influencing cognitive process

and behaviour of people. Both are learned and acquired from the same sources – people and objects. Both are relatively permanent and resistant to change. Both values and attitudes influence each other and are used interchangeably. Hence, values people hold can explain their attitudes and, in many cases, the behaviours they engage in. However, we cannot determine which values underlie which attitudes and behaviours.

### **Sources of Attitudes**

As already explained, attitudes, like values, are acquired from the environment - parents, teachers, friends, and colleagues. It may be noted that they are only acquired but not inherited. We begin modeling our attitudes after those we admire and respect. We observe the way family members and friends behave and we shape our attitudes and behavior to align with theirs. You tend to imitate the attitudes of famous persons or those you admire and respect. Attitudes may also be developed from a personally rewarding or punishing experience with an object or event. If employees are rewarded for being regular in an organization, you are likely to believe that you will also be rewarded if you are regular.

In contrast to values, attitudes are less stable. That is why advertising messages attempt to change your attitudes toward a certain product or service. If Maruti Company is able to create a favorable opinion towards their car, that attitude may lead to a desirable behavior i.e., the purchase of Maruti car.

Therefore, sound understanding of attitudes is important for managers because they affect job behavior. Manager's knowledge can serve two purposes. Firstly, it helps him in understanding and predicting how a person is likely to behave. Secondly, it helps him in changing unfavorable attitudes into favorable attitudes.

### **Types of Attitudes**

A person may have a multitude of attitudes, but for the purpose of our study let us know about the job-related attitudes. These job-related attitudes are positive or negative evaluations held by employees about various aspects of their work environment. Essentially, there are three important attitudes concerned with job: *job satisfaction*, *job involvement*,



*and organizational commitment.*

## **Job Satisfaction**

One of the tasks of a manager is to provide job satisfaction to the employees. Job satisfaction refers to an individual's general attitude toward his or her job. A person with a high level of job satisfaction holds positive attitudes toward the job, while a person with low job satisfaction holds negative attitudes towards the job. When we talk about employee attitudes, mostly we mean job satisfaction. As a matter of fact, the two are closely related.

## **Job Involvement**

The term "*job involvement*" is relatively a recent concept in the literature. There is no complete agreement over what the term means. Generally, it refers to the degree to which a person identifies with his job, actively participates in it, and considers his performance important to his self-worth. Individuals who express high involvement in their jobs are likely to be more productive, have higher satisfaction, and are less likely to resign than employees with low involvement.

## **Organizational Commitment**

Commitment reflects an individual's orientation toward the organization by tapping his or her loyalty to, identification with, and involvement in the organization. Individuals who are highly committed see their identity as closely attached to that of the organization. Like job involvement, highly committed employees will be better performers and have lower turnover than those with low levels of commitment to the organization.

It may be understood that when people talk about job attitudes and their impact on behavior, obviously they are referring to the positive or negative appraisals that people make about their job or organization. Job satisfaction is the most popular attitude measured in organizations, but more recently there has been increased attention given to job involvement and organizational commitment. All these attitudes are measured with a view to predict employee behaviours like performance, productivity,

absenteeism, turnover and unionization.

## **Implications of Attitudes**

### **Attitudes and Productivity**

The attitude-productivity relationship is not very clear. Bradfield and Crockett in 1955 made an extensive study of this relationship and concluded that there was minimal or no relationship between attitudes and performance. However, two years later, Herzberg and his associates concluded from the review of studies that there was generally a positive relationship between attitudes and productivity. However, they noted that in many cases the correlations, although positive were low. Similarly, a review in 1964 of twenty-three separate studies revealed that, except in three cases, there was a low but positive relationship between satisfaction and performance. It is clear that the studies on the relationship between attitudes and productivity give rise to mixed findings.

### **Attitudes and Withdrawal Behaviors**

It was found in earlier studies that employee satisfaction is inversely related to absenteeism and turnover. The higher the job satisfaction on the part of an employee, the lower is the scope for employee's withdrawal behavior. Bradfield and Crockett found a significant but complex relationship between attitudes and both absenteeism and turnover. Vroom found a consistent negative relationship between job satisfaction and turnover, but a less consistent negative relationship between satisfaction and absenteeism. A few studies have also found that satisfaction has a consistent impact on absenteeism, but an even more profound and consistent relationship on turnover. However, the conclusion that employee satisfaction and absenteeism are inversely related has come under attack in the recent times.

There is also a view that organizational commitment is a better predictor of voluntary resignations than job satisfaction. If this is true, efforts to develop valid measures of organizational commitment may be of greater importance to managers. In conclusion, the evidence is fairly clear that organizations with committed and satisfied employees have lower rates of both turnover and absenteeism.

## **Attitudes and Satisfaction**

Attitudes towards job and job satisfaction are closely related. In many research studies, these terms are used interchangeably. In studies of job attitudes, it is generally thought that the result is some measure of job satisfaction or dissatisfaction. Job satisfaction, however, is not a behavior but rather a general feeling of contentment with the job. As a result, if attitudes are positive, job satisfaction tends to be positive. On the other hand, if the attitudes are negative, satisfaction tends to be low. Therefore, if a manager wants to have employees satisfied with their jobs, he should strive to create in them positive attitudes toward their job and the organization.

### **Review Questions**

1. What are values? How are they important?
2. What do you know about the values at work place?
3. What factors influence the formation of attitudes?
4. Explain the implications of job attitudes in organisations.

\*\*\*



---

## Lesson - 18 : Stress Management

---

### Objectives

*After going through this lesson, you should be able to:*

- ▶ Know The Meaning Of Stress And Its Causes;
- ▶ Understand How Stress Levels Change On The Basis Of Occupational And Individual Differences;
- ▶ Acquaint With The Consequences Of Stress On Employee Performance And Behaviour; And
- ▶ Appropriate Strategies For Managing Stress.

### Lesson Outline

- ▶ Causes Of Stress
- ▶ Occupational Differences And Stress
- ▶ Individual Differences And Stress
- ▶ Consequences Of Distress
- ▶ Managing Work- Related Stress
- ▶ Review Questions

People often think of stress in negative terms and believe that it is caused by something bad in the environment. For example, a family member becomes ill, a student fails to get admission into the desired course or an employee is scolded by his superior for late coming. All this is a form of stress. However, there is a positive side of stress caused by good things like a student securing admission into medicine or an employee getting promoted as a manager. This is called *eustress*. The Greek word **eu** means good. Therefore, at work places employees may experience bad stress as a result of demotion or good stress caused by increased job responsibility and time pressure that go with a promotion.

In fact, there are numerous definitions of job stress. Ivancevich and Matteson define stress simply as “*the interaction of the individual with the environment*”. They give a more detailed definition of stress as “*an adaptive*

*response, motivated by individual differences and/or psychological processes that are a consequence of any external (environmental) action, situation, or event that places excessive psychological and/or physical demands on a person”.*

Beehr and Newman define job stress as “*a condition arising from the interaction of people and their jobs and characterized by changes within people that cause them to deviate from their normal functioning*”. As such, stress is an adaptive response to a situation that is challenging or threatening to the person. It may be noted that stress is a person’s reaction to a situation but not the situation itself.

### **Causes of Stress**

Let us examine the causes of stress now. The factors contributing to stress are called stressors. Stressors exist in the environment and they make a physical or emotional demand on the person. Stressors emanate from both within the organization and outside which can be classified as external stressors, organizational stressors, group stressors and individual stressors as shown in the following diagram.

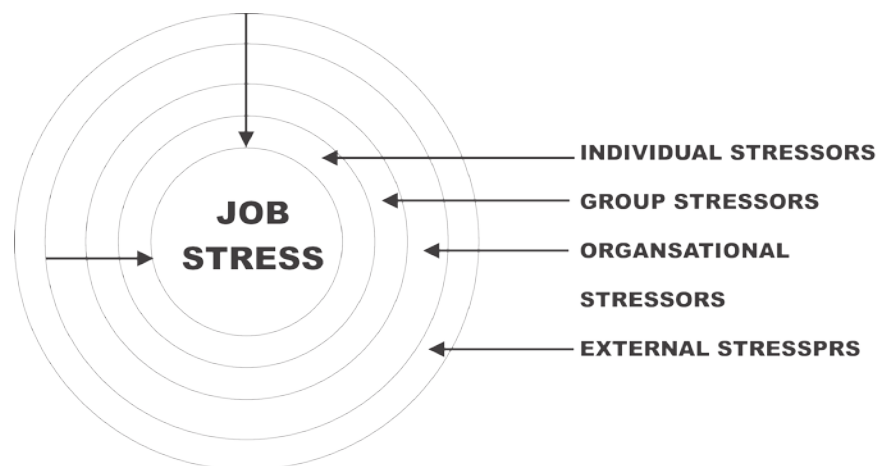

**Figure 18.1: Factors contributing to Job Stress**

### **External Stressors**

In the analysis of job stress, we tend to ignore outside forces or events. In fact, they have a greater impact on stress. Quite often, we experience plenty of stress situations outside the organizational settings. External stressors stem from societal changes, globalization, family

economic conditions, relocation, race, religion and community conditions. You have to remember that when employees join the organizations, the stressors are also carried over which affect their behaviour. In the changing situation, inspite of the advancement in medical sciences modern living is associated with increased stressful conditions. Obviously, it all tells on the health and well being of an individual. The life styles have changed significantly giving rise to several anxieties and tensions. As a result, potential job stress has increased.

Outside the organization, a person's family also plays an important role in contributing to stress conditions. An illness of the family member or a strained relation with spouse or a child may create stress for an employee. Not able to properly balance the family responsibilities and the job responsibilities, employees experience a lot of stress. For example, a psychologist reports that divorce between wife and husband interferes with work more than any other trauma in a person's life. It is pointed out that in the first three months after a spouse walks out, the employee becomes incapable of focusing on work.

In addition, now-a-days various developments in the macro level scenario like frequent communal riots, strikes, violence, religious conflicts, oppressions, harassments, kidnaps, suicides, attacks by extremists have all become a common place. Living in such an environment, a person is exposed to a variety of stressful situations.

### **Organizational Stressors**

Organizational stressors are many and manifest themselves in different forms. You may note that any change in organization is stressful. Technological changes and structural changes happen too frequently. Mergers and acquisitions are increasingly resorted to. It is needless to say that downsizing of workforce is extremely stressful to those who lose their jobs. Layoff survivors also experience stress due to higher workloads, feeling of guilt, job insecurity, and the loss of friends at work.

In the physical environment of an organization, you find stressors in the form of high temperature, excessive noise, lack of privacy, poor lighting, safety hazards and poor quality of air. A study observed that in a noisy plant, level of stress significantly decreased when they were supplied

with ear protectors. In another study, it was found that clerical employees experienced significantly higher stress levels in noisy open offices than in quiet areas.

### **Group Stressors**

As you are aware, within an organization, there are several groups that function at different levels. A number of stressors arise at group levels which are discussed below.

#### **Lack of Group Cohesiveness:**

Cohesiveness means “*togetherness*”. Employees should remain a cohesive group. If the cohesiveness does not exist among employees, it may lead to job stress. Cohesiveness of the group may be lost because of the task design, or animosities of group members, or the supervisor trying to limit it.

#### **Lack of Social Support:**

Employees have different social groups for different purposes. These play an important role in extending support to an employee. By sharing their joy and sorrow with others, they feel comfortable and happy. In the absence of this kind of mutual social support, the situations prove to be very stressful. There are research studies indicating that lack of social support is so stressful that it results in health care costs. You may note that group level dynamics may also act as stressors. A study indicated that organizational politics was a potential source of stress in the work environment.

### **Interpersonal Stressors**

Interpersonal stressors like group competition, ineffective supervision, office politics, and other conflicts are many in the organizations. The more an employee is required to interact with other people, the more is the scope for stress. As you are aware, in banks and call centers, the employees experience a lot of stress because of the uncooperative customers and high targets to be achieved.



## **Individual Stressors**

At individual level, there are many factors that contribute to stress, most of which are role related. Role related stressors include conditions where employees have difficulty in understanding, reconciling, or performing the various roles in their lives. The four main role-related stressors are role conflict, role ambiguity, workload, and task control.

### **Role Conflict**

Role conflict occurs when people face competing demands. Inter-role conflict exists when employees have two roles to play which are conflicting. For example, people in supervisory cadre in organizations face this kind of conflict as they have to meet the expectations of management on the one hand and the expectations of workers on the other. Role conflict also occurs when an employee receives contradictory messages from two superiors about how to perform a task or work with organizational values and work obligations that are incompatible with his or her personal values. The working women often experience role conflict between their job responsibilities and family obligations.

### **Role Ambiguity**

Role ambiguity exists when employees are uncertain about their job duties, performance expectations, level of authority, and other job conditions. This ambiguity tends to occur when people enter new situations like joining as a manager in an organization accepting a foreign assignment. This is because they are uncertain about task and social expectations that go with the new positions.

### **Workload**

Workload is a well-known job stressor. But you remember that work under-load, receiving too little work or having tasks that do not sufficiently use your talents, is also a possible stressor. Now -a-days, employees have either too much to do in too little time, or they work too many hours on the job. Long work hours may lead to unhealthy lifestyles, which, in turn, cause heart disease, back pain or eye sight. For instance, work overload is a problem in most of the software organizations in India

leading to health problems.

### **Occupational Differences and Stress**

Several studies have attempted to identify which jobs have more stressors than others. You may note that one problem with rating occupations in terms of their stress levels is that a particular occupation may have considerably different tasks and job environments in different organizations and societies. The job of a police officer may be less stressful in a small town than in a large city where crime rates are higher and the organizational hierarchy is more formal.

Another important point for you to remember is that a major stressor to one person may be insignificant to another. We cannot conclude that people in high-stress occupations actually experience higher stress than people in other occupations. Some jobs expose people to more serious stressors, but careful selection and training can result in stress levels no different from those experienced by people in other jobs.

### **Individual Differences and Stress**

You have already understood that individuals differ in their personality characteristics. These differences determine the stress levels experienced by the people. Two people may be exposed to the same sources of stress like meeting a deadline for achieving a goal. However, in terms of stress levels they may be different.

Some individuals are more prone to stress than others. It may be on account of demographic differences and cognitive differences. Demographic differences are related to age, health, education and occupation. Age causes stress because as people go through the life stages, certain things are expected of them. As they grow, they have to shoulder greater responsibilities. Health is another factor influencing stress. Healthy people can cope with stress more than sick people. Education is also important in this context. If the person is not educated, he feels unworthy and that may cause stress. Coming to occupation, it is needless to say that every occupation involves some kind of stress or other.

Cognitive differences are satisfaction, locus of control and type of personality. Persons having greater urge for satisfaction work hard and try

to excel others. This may lead to overwork and also burnout. Locus of control refers to one's feeling of the extent to which he is able to control the surrounding world. The greater the person's perception of control over the environment, the lesser is his proneness to stress. Another cognitive factor is personality. As explained earlier, there are two types of personalities – Type A and Type B. Type A personalities are involved in struggles to get more and achieve more. Therefore, they are more prone for stress. On the other hand, Type B personalities are more patient and easy going. They are interested in achieving goals but follow different ways for the purpose. As a result, they are less prone for stress.

## **Consequences of Stress**

Stress has serious consequences on health as well as job performance. Stress results in a variety of physiological, psychological, and behavioral consequences.

### **Physiological Consequences**

Stress takes its toll on the human body. Studies have found that students who are anxious about their exams are more susceptible to colds and other illnesses. As you are aware, many people experience tension or headache due to stress. Others get muscle pain and related back problems. These physiological ailments are attributed to muscle contractions that occur when people are exposed to stressors.

### **Psychological Consequences**

Stress results in various psychological consequences like job dissatisfaction, moodiness, and depression. Emotional fatigue is another psychological consequence of stress which is called job burnout.

### **Job Burnout**

Burnout is the process of emotional exhaustion, depersonalization, and reduced personal accomplishment resulting from prolonged exposure to stress. The term “job burnout” was not known 50 years ago; but it's a much talked about phenomenon these days. Job burnout is a complex process that includes the dynamics of stress, coping strategies, and stress

consequences. Burnout is caused by excessive demands made on people who serve or frequently interact with others. Interpersonal and role-related stressors cause burnout.

There are three components of job burnout. The first one is **emotional exhaustion**, which plays a key role in the burnout process. It is characterized by lack of energy and a feeling that your emotional resources are exhausted. Emotional exhaustion is sometimes called compassion fatigue because the employee no longer feels able to give as much support and caring to clients.

The second one is **depersonalization**, which is identified by the treatment of others as objects rather than people. Employees subjected to burnout become emotionally detached from clients and cynical about the organization. This detachment reaches the point of callousness far beyond the level of detachment normally required in execution of tasks, more particularly in service sector. Depersonalization can be seen when employees strictly follow rules and regulations rather than try to understand the client's needs and search for a mutually acceptable solution.

The third component of job burnout is **reduced personal accomplishment**. It refers to the decline in one's competence and success. In other words, the person's self-efficacy declines. In these situations, employees develop a sense of learned helplessness, as they no longer believe that they make a difference.

### **Behavioral Consequences**

When stress becomes distress, job performance comes down and workplace accidents increase. High stress levels impair your ability to remember information, make effective decisions, and take appropriate actions. You probably experience this kind of distress in exams. You are likely to forget important information and commit mistakes.

Overstressed employees also tend to absent from work frequently. This is because stress makes people sick. Sometimes absenteeism is used as a stress coping mechanism. Normally, we react to stress through fight or flight. Absenteeism is a form of flight-temporarily withdrawing from the stressful situation so that we find time to re-energize ourselves.

Sometimes workplace aggression may be the consequence of stress. Aggression represents the fight reaction to stress. In its mildest form, employees engage in verbal conflict. They are not likely to empathize with co-workers. Occasionally, it may lead to more dangerous levels of workplace hostility.

## Managing Work-Related Stress

In managing work related stress, both the organization and the employees have joint responsibility. Stress management often includes several strategies. These are shown in the following diagram.

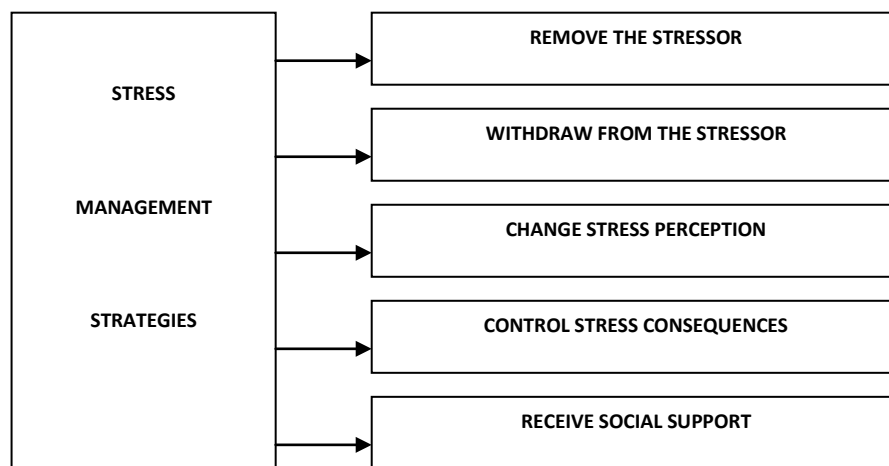

Figure 18.2: Stress Management Strategies

### Remove the Stressor

An important way companies can effectively manage stress is by removing the stressors that cause unnecessary tension and job burnout. Other stress management strategies may keep employees. “*Stress-fit*”, but they don’t solve the fundamental causes of stress.

In managing stress, organizations have to investigate the main causes of stress in their workplace. For example, you may ask employees to complete confidential questionnaires to identify when and how they experience stress. You may remember that one of the most powerful ways to remove workplace stressors is to empower employees so that they

will have more control over their work and work environment. Placing employees to positions that match their competencies can minimize role related stressors. Noise and safety risks are stressful, so improving these conditions would also go a long way to minimize stress in the workplace.

### **Family-Friendly and Work-Life initiatives**

The most common work-life balance initiatives are flexible work time, job sharing, telecommuting, personal leave programs, and childcare support. Many firms have flexible timings with regard to the hours, days, and amount of time employees want to work.

Job sharing splits a career position between two people so that they experience less time-based stress between work and family. They typically work different part of the week, with some overlapping work time in the weekly schedule to coordinate activities.

Telecommuting reduces the time and stress of commuting to work and makes it easier to fulfill family obligations, such as temporarily leaving the office to pick up the kids from school. Research suggests that telecommuters experience a healthier work-life balance. Employers with strong work-life values offer extended maternity, paternity, and personal leaves to care for a new family or elderly parents who need assistance. Childcare support reduces stress because employees need not rush to drop off their children and less worried during the day about how well they are doing.

### **Withdraw from the stressor**

Removing the stressor may be an ideal solution, but that is not always possible. An alternative strategy is to permanently or temporarily take employees away from the stressor. Permanent withdrawal occurs when employees are transferred to other jobs.

### **Change stress perceptions**

You have earlier learnt that employees experience different levels of stress in the same situation because of their perceptual differences. Therefore, changing perceptions of the situation can minimize stress.

This strategy does not involve ignoring risks or other stressors. Rather, it involves strengthening the self-efficacy and self-esteem of a person so that job challenges are not perceived as threatening.

### **Control the consequences of stress**

Managing workplace stress also involves controlling its consequences. Research studies show that physical exercise reduces the physiological consequences of stress by helping employees lower their respiration, muscle tension, heartbeat and stomach acidity. Beyond fitness programs, some companies offer wellness programs that educate and support employees in terms of better nutrition and fitness, regular sleep, and other healthy habits. Another way to control the physiological consequences of stress is through relaxation and meditation.

### **Employee Assistance Programmes**

Now-a-days many large firms offer **employee assistance programs** in the form of counseling services that help employees overcome personal or organizational stressors and adopt more effective coping mechanisms. Personal problems and family problems are solved through these programs. Employee assistance programs can be one of the most effective stress management interventions where counseling helps employees understand the stressors, acquire management skills and practice those skills.

### **Receive Social Support**

Receiving social support from co-workers, supervisors, family, friends, and others is one of the more effective stress management strategies. Social support refers to the person's interpersonal transactions with others and involves providing either emotional or informational support to buffer the stress experience.

Social support reduces stress in at least three ways. *First*, employees improve their perception that they are valued and worthy. This, in turn, increases their self-esteem and perceived ability to cope with the stressor. *Second*, social support provides information to help employees interpret, comprehend, and possibly remove the stressor. *Finally*, emotional support

from others can directly help buffer the stress experience. People seek out and benefit from the emotional support of others when they face threatening situations.

### **Review Questions**

1. What is job stress?
2. What are organisational stressors?
3. How do stress levels change from one individual to another?
4. What strategies do you adopt for managing job stress?

\*\*\*



---

## Lesson - 19 : Communication

---

### Objectives

*After reading this lesson, you should be able to:*

- ▶ Understand The Process Of Communication;
- ▶ Know The Types Of Communication;
- ▶ Familiarize With The Barriers To Communication And How To Overcome Them.

### Lesson Outline

- ▶ Meaning & Definition
- ▶ Characteristics Of Communication
- ▶ Elements Of Communication
- ▶ Barriers Of Communication
- ▶ Review Questions

Communication is perhaps as old as the human civilization. Its origin can be traced to the growth of the human society. In the primitive stage of human society, man satisfied his wants which were limited to the basic needs of food, clothing and shelter by his own efforts. Life was isolated and there was little communication. But while man hunted for food, he too was hunted by wild animals. He lived in constant danger. The common need of protection led to group life. Communication was in the form of codes, indications, signals and expressions. As group life developed and wants continued to increase, forms of expressing ideas in languages developed. Science entered the field and means of oral communication developed. In the present day world of mass production, involving large number of personnel, communication is the vital need at every step in industrial and commercial activities.

## **Meaning**

The term 'communication' is derived from the Latin word 'communis' which means common. The term communication is used to signify the act of transferring ideas or receiving it by any means-word of mouth, the telephone, telegram, letter, message etc. In an organisation managers have to communicate constantly. If we observe the activities of any manager, we will find that he is busy writing a letter or receiving one, meeting a worker or a group of workers or his superior attending a conference or addressing one, telephoning or discussing a project with an expert, negotiating terms and so on. Managerial functions are discharged through communication. Direction, guidance, delegation of authority, assignment of duties etc., are done through communication. Thus communication is not a one way process.

## **Definition of Communication**

The term "*communication*" is freely used by everyone. It is one of the most frequently discussed subjects in the field of organisational behaviour. According to Louis Allen, *Communication* is the sum of all things, a person does when he wants to create an understanding in the mind of another. It involves a systematic and continuous process of telling, listening and understanding.

According to Keith Davis, "It is the process of passing information and understanding from one person to another. It is essentially a bridge of meaning between people. By using this bridge of meaning, a person can safely cross the river of misunderstanding that separates all people".

Thus, in reality communication is the sum total of direct or indirect, consciously or unconsciously transmitted words, attitudes, feelings, actions, gestures and tones. Even silence is an effective form of communication. A twist in the face is often more expressive than a 100 words put together. Tone very often than not, conveys the meaning of the words uttered.

## Characteristics of Communication

The following are the characteristics of communication.

1. Communication is a two-way process because orders, instructions, directions, guidelines, etc., are directed or communicated downwards while suggestions, complaints, grievances etc., are communicated upwards. This not only involves giving ideas but also receiving them.
2. No business organisation can exist without communication because it is necessary to have a congenial relationship between the different employees working at different levels and that is why it is a continuous process.
3. The communication process continues to the extent that ideas and messages are communicated and received.
4. It may be formal or informal and it may be in different mediums.

## The Communication Process

Communication process contains the following elements:

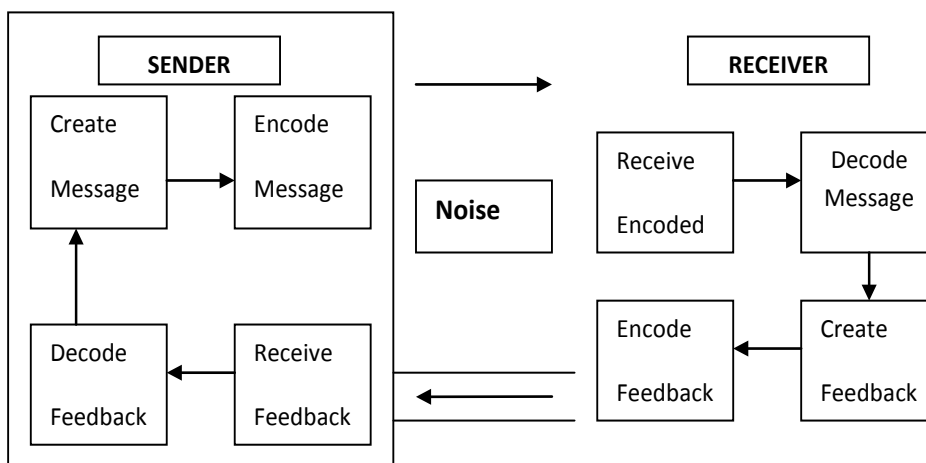

Figure 19.1: The Communication Process

### 1.The Communicator

Communication commences with the communicator. He is the sender of the message. He realizes the need for conveying something to someone else. A communicator or the sender is the source of

communication. He has a purpose of communicating some information to one or more persons.

## **2.Encoding**

Encoding means putting message into code. A message is initiated by encoding a thought. The communicator encodes the information to be transmitted. It is done by translating into a series of symbols or gestures. Encoding is essential because information can be conveyed only through representations or symbols. The sender of the message should establish mutuality of meaning with the receiver. Coded messages may be oral or written words or gestures.

## **3.The message**

A message is the output of encoding process. It is the physical form of the encoded message. The message may be in any form- oral, written or gesture. But it must be unambiguously understood by the receiver. Speech may be heard. Written words may be read. Gestures may be seen or felt. Message must be clear and precise.

## **4.The Medium**

The communicator can communicate the message through a medium. The medium is the carrier of communication. The communication channel is the mode of transmission. Air is the medium for oral message. The medium is inseparable from the message. It links the sender with the receiver. The message may be conveyed through a memorandum, letter, telegram, the telephone, a computer or T.V., but the channel or the medium must be appropriate for the message. At times, multiple media are used for effective communication. A telephone talk may be confirmed by a letter later. Since the choices of channels are many, proper choice of the channel is vital for effective communication.

## **5.Decoding**

Decoding refers to the finding of the meaning of something conveyed in code. It is the process by which the receiver interprets the message. It

means translating the message that is significant and meaningful to the receiver. The recipient has to be ready for the message. Then only the message can be decoded into thought. In decoding, the receiver converts the message into thoughts. Decoding is affected by several factors such as the recipient's knowledge, past experience, personal interpretations of the symbols and gestures used expectations and mutuality of meaning. Thus, decoding is very important for understanding the message.

## **6.The Receiver**

Communication requires atleast a couple of people, the sender and the receiver. One “encodes” and the other “decodes” the message. It will be complete only when the receiver perceives the message intact. The receiver must decode the message without distortion. If the message does not reach a receiver, communication cannot be said to have taken place.

## **7.Feed Back**

Feedback refers to the reaction of the receiver. It is a reversal of the communication process. Feedback enables the communicator to know whether his message is received and interpreted correctly or not. Further, Feedback enables the communicator to know the reaction of the receiver so that future communication can be modified, if necessary. The importance of Feedback is incalculable. It helps to check the effectiveness of communication. It makes communication a two-way process.

## **8.Noise**

“Noise” is the enemy of Feedback. It refers to any factor that interferes with communication. Interference may occur in all the above stages of the communication process. It hinders or blocks communication.

## **Importance of Communication**

Civilization will cease without communication. Over the years, the importance of communication has increased tremendously thanks to the advent of various modern devices. The following points bring out the importance of communication in management.

## **1. Smooth Running of the Enterprise**

Effective communication ensures the smooth running of an enterprise. Communication plays a vital role in all kinds of organisations. In the case of complex organisations, effective communication solves lot of problems. The work of the subordinates depends to a large extent upon the communication they receive from their superiors. Similarly, successful completion of the task by the superior depends upon the nature and flow of communication from the subordinates to the superiors.

## **2. Quick Decisions and Implementation**

Communication greatly facilitates decision making. However intelligent the personnel may be, it would be of no use, if the top management cannot effectively communicate policies and decisions to them. Effective implementation of decisions depends upon the nature of communication. It is said that communication acts as a lubricant and keeps all the individuals working in line with the expectations of top management.

## **3. Planning and co-ordination**

Communication greatly helps in planning and co-ordination. Participation in planning is essential in order to successfully execute it and this is secured by communication. Similarly, co-ordination between various individuals and activities is brought out by communication.

## **4. Maximum Productivity**

Maximum output with minimum input is the aim of all managers; this can be achieved by effective communication. Communication helps in minimizing costs and friction and maximizing production.

## **5. Morale Building and Democratic Management**

When there is an effective system of communication, employees

will have the opportunity to present their ideas, suggestions and complaints. If the grievances are not set right at the early stage, they will ultimately result in industrial unrest. It is pointed out that many conflicts arise because of lack of communication or mis-understood motives. Democratic management is possible only when there is an effective communication system.

## **Types of Communication**

We spend a great deal of our time in communication. No one can afford to waste time by indulging in unnecessary communication. It is often very difficult to determine which communication is necessary and which is not necessary. Again it is difficult to determine the extent of information to be passed on. The method of presentation is also to be decided - narrative, statistical or graphical form. The following are some of the types of communication.

### **Verbal or Oral Communication**

In this method of communication the two parties exchange their ideas or the message with the help of word of mouth. The message, instruction, order, directive etc., is conveyed through spoken words. Examples of verbal communications are – telephone talk, oral orders, face to face talks, counseling etc. Some of the advantages of verbal communication are as follows:

- It saves time and money. No other device is so short, simple and quick.
- Because of the face contact or personal touch, it is effective.
- Oral communication is easily understood. Even when there are doubts they can be cleared on the spot.
- The effect of the communication or response to the communication can be easily measured. Suitable changes can also be done immediately.
- During periods of emergency, oral communication is the best method.

However, oral communication is not suitable in the following cases:

- When the communicator and the recipient are far off, (beyond the telephone range) oral communication will not serve the purpose.
- If the message to be transmitted is lengthy and requires a thorough clarification, oral communication will not be suitable.
- Oral communication does not serve as a record or as evidence. It cannot be made use of in future.
- There are chances of misunderstanding and mis-interpreting the communication.

### **Written Communication**

A written communication is conveyed through a letter, report, circular notes, memoranda, notice and communiqué. It is a very common form of communication in most of the organisations and is suitable for many situations.

The usual forms of written communication are:

Orders – given by the superiors to the sub-ordinates. These can be of three types.

- a. General
- b. Specific
- c. Definite

*General orders* are given by the top management, *specific orders* by the middle level management to lower level managers and *definite orders* by the supervisor to workers.

- Instructions given by the departmental heads to supervisors and by the supervisors to their sub-ordinates.
- Reports submitted by the authorized persons. These are of three types.

(a)*Routine reports*- which are prepared periodically and are a regular feature.

(b)*Commission reports*- which are of a non-routine nature and are prepared under special orders.

(c)*Special circumstances reports*.



### **Written communications have the following advantages.**

- They serve as permanent record and as a source or reference.
- More care is taken in drafting written communication (than is in the case of oral communications) and this saves the subsequent loss of time and money.
- When the communicator and recipient are far off, written communication is the best method.
- The recipient can ponder over the communication and request for changes, if necessary.

### **The disadvantages are listed below:**

- As everything is to be translated into black and white, it consumes a lot of time and money.
- People do not care at all to pass the appropriate message. Consequently, poor messages are to be followed by clarifications and explanations.
- Sometimes it may not be possible to reduce everything into writing. Any omission will call for additional communication.
- Written communication is subject to delay and red tapism.
- It is very difficult to keep some communications up to date.

### **Formal and Informal Communication**

The formal organisation chart describes the formal lines of authority, power, responsibility and accountability of the organizational members. All these relationships involve communication. For instance, the delegation of authority involves the flow information from a superior to his subordinate. Formal communications are in black and white.

On the other hand, informal communication is free from all the formalities of formal communication. Informal communication is based on the informal relationship among the organisation members. It is conveyed by a simple gesture, glance, nod, smile or mere silence. For instance, when the worker approaches the manager and informs about the completion of the job entrusted to him, and if the manger simply nods his head or gives an approving smile, then it amounts to informal communication.

The informal communication which supplements the formal organizational relationship is referred to as the “Grapevine”. Though this relationship is structureless, it comes into existence when formal organizational members who know each other pass on information relating to the enterprise. It thrives on information not openly available to the entire work group. This may be due to the fact that information is regarded as confidential. The Grapevine may flourish, if formal lines of communication are inadequate. The Grapevine is inevitable and valuable, because all forms of informal organisation serve essential human communication needs. It is very effective for quick communication.

### **Downward, Upward or Horizontal Communication**

Communications are classified as downward, upward or horizontal. Communication is said to be downward when it flows from the top to the bottom, it is upward when it flows from the sub-ordinates to the top management. It is horizontal when it flows between individuals at the same level (e.g. between two departmental or section heads). All these three kinds of communications may be either oral or written. The Classical theorists emphasized downward communication. Downward Communication is used by the superiors to convey their orders and directions to their sub-ordinates. The purposes of downward communication are:

- a. To give job instructions
- b. To create an understanding of the work and its relations with other tasks.
- c. To inform about procedures.
- d. To inform sub-ordinates about their performance.
- e. To indoctrinate the workers to organizational goals.

### **Barriers to Communication**

It is not possible that every time an order, instruction, guideline, direction, programme, information etc, transmitted by the superior is properly understood and assimilated by those for whom it is intended. Similarly suggestions, reports, advice, recommendations, complaints, etc., transmitted by the sub-ordinates to their superiors may be misunderstood or mis-interpreted. In any case, the objectives of communication are defeated.

As such, the process of communication is not always smooth. It is obstructed by many obstacles. These are referred to as barriers of communication. It refers to those factors which cause disturbance either in the mind of the communicator or the communicatee or in the process, which will create distortion of the message, leading to lack of the response, ignoring or mis-understanding. The important barriers to effective communication are:

### **Ineffective Expression**

The first and the most common barrier in the process of communication is bad expression. This means that the messages suffer from omissions, uncertainty, inaccuracies, verbosity, repetitions, ambiguity, lack of clarity and precision. In order to remove this, the staff should be trained to draft various kinds of effective communication. This will save time because otherwise much time has to be devoted in giving subsequent clarifications.

### **Inaccurate Translation**

Decisions are generally conveyed from the top to the lower level. The superiors are known for their specialised knowledge. They generally draft messages in a technical language which may not be clearly understood by those who have to implement the decisions. Even if they are able to understand, they may not be able to convey it further down the line in simple words.

In many such cases, it becomes necessary to translate the subject matter or the message into a simpler language, i.e., the language which the Communicatee can understand easily. But the translation may be done inaccurately. Sometimes the translator is not in a position to find out the equivalent of many terms. With the result, the translation leads to further confusion. It becomes necessary that competent persons are appointed for the job and are provided the necessary equipment for the execution of the entrusted tasks.

## **Inattention**

**Inattention** is a very common and chronic human failing. This barrier generally arises in case of oral communication. It can be illustrated with the help of the following example: a superior is giving a message on the telephone. The subordinate is busy reading a magazine or looking through the window or his mind is occupied with some family problem. Superiors have to face this problem of inattention quite frequently. Efforts to communicate fails. The communicator should choose the appropriate time for communicating. Thus, for example, communicating at lunch hour or while at rest will not invite due attention. Holding a meeting at an odd time or calling the worker over for a talk on a holiday are some other examples.

## **Loss in Transmission**

Loss in transmission is another barrier of communication which arises in oral communication. When messages are conveyed from the higher to the lower level step by step, much of it is likely to be lost in transit. This problem may arise in case of written communication as well. At every level the superior will interpret the message which is likely to be distorted. Further, the meaning will change if some words are dropped, changed or misspelt. Harold Koontz and Cyril O'Donnell estimate that about 30% of the information is lost in each transmission. Written communications too are subject to loss in transmission. It is no wonder that enterprises often operate in a cloud of ignorance.

## **Vague and Unclarified Assumptions**

The object of a communication is to distinctly tell the communicatee what is desired of him. If the message is not clear in meaning, assumptions are not clear to the personnel; communication will lose its purpose. If the personnel are not able to know what they are supposed to do even after receiving the message, the communication will be no more than a waste paper.

## **Inadequate Adjustment Period**

Certain messages affect a large number of people in their personal life. For example, a notice is issued informing change in the timings of the shift in a factory. This requires sufficient lead time for the workers to make an adjustment. In case sufficient time is not granted there will be a communication barrier.

Similarly communications regarding changes in the rules about bonus, over time should allow an adjustment period. Sufficient time should be allowed to the employees to adjust their schedule or get themselves mentally prepared.

### **Distrust**

It arises if the superior is known for making frequent changes in the communication, quite often even reversing the original message. It is due to ill conceived adjustment, improper technology, etc. Repeated experience of this type will damage employee's interest in the communication.

### **Fear**

This indicates anxiety, awe, alarm or apprehension. This arises in upward communication and creates a barrier in communication. It may be illustrated as below. A subordinate is not sure if the information conveyed by him to the superior will be useful or not. He thinks if it is not liked, boss will be annoyed and might take action against him. He requests another subordinate to transmit the information on his behalf.

### **Noise, Distance and Time**

The world will not be worth living in, if it is quiet everywhere. But at the same time noise is a big menace. In modern factories the constant rattling of the machines and tools, the squeaking of the wheels constantly create a lot of noise. And noise proves a great barrier to communication. It is a very common experience that noise proves a big hindering factor if two persons are talking. If somehow the noise is not controlled, it may not be possible for communicatee to listen anything or make out the sense. He will properly feel strained.

Let us consider the following example:

- a. An executive is giving a message on the telephone. But the subordinate is not able to get it properly because of the noise of the traffic.
- b. There is a strike in a factory. Workers are not coming to their jobs. The factory manager calls a meeting of their representatives and wants to tell them certain things. But he is not in a position to do so because the workers are shouting very loudly. Distances act as barriers in the process of communication. If the two parties are very far from each other there will be difficulty in communication. Telephone solves this difficulty in many cases. But bad weather, technical defects, break down and rain may render the telephone useless. Thus because of these two barriers the message is not communicated properly at the right time. Failure to do so, results in dislocation of managerial plans rendering the attainment of the objectives in doubt.

## **Impression**

Sometimes in an effort to impress others, the communicator starts talking in a confused manner or speaks with a changed pronunciation. These actions hinder communication. It leads to wastage of time, resources and energy and causes misunderstanding.

### **How can Communication be more Effective**

The following aspects, if taken care of, will make communication effective.

## **Clarity of Thoughts**

The idea to be transmitted must be absolutely clear in the mind of the communicator. Just as it is not possible to have a clear print from a blurred negative, similarly one can never make his views intelligible to others, if he himself is confusing at certain points. Hence the process of communication to be complete must spring out from a clear head. Further, the academic level of the workers, their power of grasping things etc., should also be taken into account. Even when the language spoken by the workers, superiors and the management is the same, words often mean different things to people with a different experimental background.

## **Attach Importance to Actions Rather Than Words**

In all communications, actions are more significant than words. A manager who invariably says that he trusts subordinates and then proceeds to make too many checks on the subordinate's work, usually fails to make himself understood. A boss who is not punctual cannot succeed in enforcing the timing-rules on the subordinates.

## **Participation**

The next most important essential point is that both the parties (communicator and the recipient) should participate in the communication process. It is a common complaint of the workers that proper and patient hearing is not given to their voice. Listening plays a very fundamental part in oral communication because it is listening only which leads to sharing, participation and understanding in oral communication. But this listening is not merely passive hearing. It is an art which is to be perfected with practice based on sound knowledge of the principles of human nature.

- a. Some of such important principles are;
- b. Respect the personality of employees.
- c. Recognise both subjective and objective facts.
- d. Avoid moralizing. For example telling an emotionally upset worker that he should be calm and talk reasonably and logically may only succeed in erecting a barrier against further expression of his

difficulties.

- e. Hasty generalizations are dangerous; e.g., union stewards cannot be trusted, all workers are dishonest.
- f. Knowledge of one's own prejudices will help proper listening.

### **Transmission**

The communicator must plan carefully what to communicate, whom to communicate and how to communicate. Further, delegation of authority without responsibility breaks down the spirit of communication.

### **Keep the channel Always Alive**

The channel of communication should be kept open and alive. It is only by honest attempts that good communication relations can be developed.

### **Cordial Superior-Subordinate Relationship**

Effective communication requires good quality of relationship between people immediately connected with each other. It requires sound industrial relations, policies and practices, an all round atmosphere of friendly co-operation and a feeling of trust and confidence throughout the organization right from the top management down to the humblest worker. Under such conditions only, the meaning of communication is grasped quickly and correctly. On the other hand, if the relations are not satisfactory, much of the information may be suppressed or misunderstood.

### **Review Questions**

1. Examine the process of communication and explain the various elements of it.
2. What are the different types of communication? Explain the merits and demerits of each?
3. Distinguish between formal and informal communication.
4. What are the different barriers of communication?
5. What is your prescription to overcome the barriers of communication?

### **Case Study**

The ABC Manufacturing Company is a metal working plant under the direction of a plant manager who is known as a strict disciplinarian. One day a foreman noticed Bhola, one of the workers, at the time-clock punching out two cards – his own and the card of Nathu, a fellow worker. Since it was the rule of the company that each man must punch out his own card, the foreman asked Bhola to accompany him to the Personnel /Director, who interpreted the incident as a direct violation of a rule and gave immediate notice of discharge to both workers.

The two workers came to see the Personnel Director on the following day. Nathu claimed innocence on the ground that he had not asked his card be punched and did not know at the time that it was being punched. He had been offered a ride by a friend who had already punched out and who could not wait for him to go through the punch-out procedure. Nathu was worried about his wife who was ill at home and was anxious to reach home as quickly as possible. He planned to take his card to the foreman the next morning for reinstatement, a provision sometimes exercised in such cases.

These circumstances were verified by Bhola. He claimed that he had punched Nathu's card the same time he punched his own, not being conscious of any wrongdoing.

The Personnel Director was inclined to believe the story of the two men but did not feel he could reverse the action taken. He recognised that these men were good workers and had good records prior to this incident. Nevertheless, they had violated a rule for which the penalty was immediate discharge. He also reminded them that it was the policy of the company to enforce the rules without exception.

A few days later the Personnel Director, the Plant Manager and the Sales Manager sat together at lunch. The Sales Manager reported that he was faced with the necessity of notifying one of their best customers that his order must be delayed because of the inability of one department to conform to schedule. The department in question was the one from which the two workers had been discharged. Not only had it been impossible to replace these men to date, but disgruntlement over the incident had led to significant decline in the cooperation of other workers.

The Personnel Director and the Sales Manager took the position that the discharge of these two valuable men could have been avoided if there had been provision for considering the circumstances of the case. They pointed out that the incident was costly to the company in the possible loss of a customer, in the dissatisfaction within the employee group and in the time and money that would be involved in recruiting and training replacements.

The Plant Manager could not agree with this point of view. "We must have rules if we are to have efficiency and the rules are no good unless we enforce them. Furthermore, if we start considering all these variations in circumstances, we will find ourselves loaded down with everybody thinking he is an exception". He admitted that the grievances were frequent but countered with the point that they could be of little consequences if the contract agreed to by the union was followed to the letter.



## Questions

1. Place yourself in the position of the Personnel Director in this situation. Which of the following courses of action would you have chosen in consideration of the information which was at the time of the decision?

- a. Would you have discharged both men?
- b. Would you have discharged Bhola only?
- c. Would you have discharged Nathu only?
- d. Would you have discharged neither of them
- e. Justify your choice of decision.

2. What policy and procedural changes would you recommend for the handling of future cases of this type? How do you see the loss to the company? Examine.

\*\*\*



## UNIT - IV

---

### Lesson - 20 : Group Dynamics

---

#### Objectives

*After reading this lesson, you should be able to:*

- Understand How Groups Are Formed In The Organizations;
- The Influence Of Groups In The Work Place; And
- Manage The Groups Effectively To Achieve The Organization Goals.

#### Lesson Outline

- Types Of Groups
- Theories Of Group Formations
- Reasons For Formation Of Groups
- Review Questions

The behavior of people as an individual and as a member of a group widely differs. It may be noted that modern organizations are made up of people and obviously any organization is as good as its people. It is also true that individuals in an organization do not work in isolation. Much of the work in organization is done by groups of people. Therefore, it is important for a manager to understand how groups are formed in the organization and the performance and expectations of the members of various groups.

Research has well established that people in organizations form into groups in order to fulfill their social needs. Hawthorne experiments conducted by Elton Mayo and his team established that people at the work place behave as members of a group and the membership shapes their work behavior and attitudes towards organizations. *The social process by which people interact with one another in groups is called group dynamics.* Group dynamic focuses on team work where small groups contact with each other and share common ideas to accomplish the goals. Thus, a group consists of two or more persons to interact with each other consciously for the achievement of certain common objectives. The members influence the group and in turn are influenced by others in the group. To quote David Smith “*a group is a set of two or more individuals who are jointly characterized by a network of communication, a shared sense of collective identity and one or more shared dispositions with associated strength*”.

In order to be called a group, an aggregation of persons must satisfy the following conditions:

- I. People must interact with one another,
- II. People must be psychologically aware of one another, and
- III. People should perceive themselves to be a group.

Groups are useful for organizations as they provide norms of behavior for its members. They provide a mechanism for people at work place to talk to one another about job or personal problems. They provide a feeling of camaraderie, companionship and understanding. Groups enable the members gain a feeling of belongingness through which the members derive esteem, recognition and status. A sound understanding of the group dynamics at the work place keeps the manager in a good stead so that appropriate initiatives for behavior modifications and to introduce change can be implemented.

### **Types of Groups**

The following types of groups coexist in every organization.

**i. Formal Groups:** Formal Groups are a part of the organization structure. They are created deliberately by the management to perform the assigned duties. Work groups, committees and quality circles fall in this category. These groups are characterized by clear-cut authority-responsibility relationships. The pattern of communication is also well defined. Rules are laid down to regulate the behavior of group members.

**ii. Informal Groups:** Informal groups arise spontaneously at the work place because of social interaction between the people. They are created by individuals rather than by management. They are based on common interest, language, taste, religion, background, etc. Thus, informal groups are alliances that are not officially planned. These groups are natural entities in the work environment. Informal groups are more flexible than the formal groups. Since they concentrate on personal contacts between the members, they represent the human side of enterprise as compared to technical side represented by the formal groups.

**iii. Command and Task Groups:** Formal groups may be sub-classified into command and task groups. The command group is composed of subordinates who report directly to a common boss. Thus, a supervisor and the operative employees reporting to him form a command group. The task group, on the other hand, represents those working together to complete a given task. A task group or teams, say for the introduction of a new product or service, is usually formed to complete an assignment that involves a number of departments. Further, a command group is more permanent than a task group in the organization.

**iv. Interest and Friendship Groups:** Informal alliances may take the shape of interest and friendship groups. An interest group consists of people having a specific objective and not aligned to common command or task groups. For instance, employees who group together to pressurize the management for free transport and other benefits constitute an interest group. But a friendship group includes close friends or relatives. These relations even extend outside the organization. The group members know each other very well and have good relations.

## **Clique**

A clique consists of those people who have frequent interactions and observe certain norms and standards. Its purpose is to gain and control power. The number of members of a clique is restricted to five or six organizational members. Some members of a clique may also form another group which may even consist of some persons who are not members of the organization. Thus, the group known as sub-clique is partially external to the organization. Dutton has identified three types of cliques as follows:

**i. Vertical clique:** It consists of people working in the same department drawing membership regardless of ranks. For example, superior may be a member in a group consisting mainly of subordinates. Such groups cutting across hierarchical lines develop because of the earlier acquaintance of people or because the superior is dependent upon the subordinate for some formal purposes.

**ii. Horizontal clique:** It consists of people of more or less same rank and working in the same unit. This is the most common kind of informal group. The members have certain common interest for whose achievements they follow certain norms and standards.

**iii. Mixed or random clique:** Such a group draws members from different ranks, departments and physical locations that come together for a common purpose. The members may be residing in the same locality and travelling by the common bus, or they may be members of the common club.

## **Theories of Group Formation**

The following four theories explain why and how groups are formed:

### **Propinquity Theory**

Individuals affiliate with one another because of spatial or geographical proximity. In an organization, employees who work in the same area of the plant or office would more probably form into groups than those who are not physically located together. The propinquity theory explains a basic factor, i.e., proximity of people at the work place which leads to formation of groups. This phenomenon is observed in daily practice by all of us. However, it is not

essential that groups must come up because of proximity of people at the work place. There may be several other reasons for the formation of groups. Thus, the propinquity theory is not analytical; it does not consider the complexities of group behavior.

### **Homans' Theory**

According to George C. Homans, "The more activities persons share, the more numerous will be their interactions and the stronger will be their shared activities and sentiments: and the more sentiments persons have for one another, the more will be their shared activities and interactions. The Homans theory has contributed a great deal to the understanding of group formation. It is based on three concepts, namely activities, interactions and sentiments which are directly related to each other. The members of a group share activities and interact with one another not just because of physical proximity, but also to accomplish group goals. The key element is interaction because of which they develop common sentiments for one another.

### **Balance Theory**

The theory as proposed by Theodore Newcomb states that "*persons are attracted to one another on the basis of similar attitudes towards commonly relevant objects and goals. Once a relationship is formed, it strives to maintain a symmetrical balance between the attraction and the common attitudes. If an imbalance occurs, attempts are made to restore the balance. If the balance cannot be restored, the relationship dissolves.*" Both propinquity and interaction play a role in the balance theory. Thus, the balance theory is additive in nature in the sense that it introduces the factor of 'balance' to the propinquity and interaction factors. There must be a balance in the relationship between the group members for the group to be formed and for its survival. According to this theory groups are formed due to some common attitudes and values such as authority, work, life style, religion, politics, etc. They will strive to maintain a symmetrical balance between the attraction and the common attitudes.

### **Exchange Theory**

This theory is based on reward-cost outcomes of interactions. To be attracted towards a group, a person thinks in terms of what he will get in exchange of interaction with the group members. Thus, there is an exchange relationship in terms of rewards and costs of associating with the group. A minimum positive level (rewards greater than costs) of an outcome must exist in order for attraction of affiliation to take place. Rewards from interactions gratify needs while costs incur anxiety, frustrations, embarrassment, or fatigue. Propinquity, interaction and common attitudes all have roles in the exchange theory.

Besides the theoretical explanations for group formation discussed above, employees in an organization may form a group for economic security or social reasons. Economically, workers may form a group into work on a project that is paid for on a group incentive plan or form a union to demand higher wages. Joining a group provides the individual with a united front in combating indiscriminate and unilateral treatment.

### **Reasons for Formation of Groups**

**Companionship.** The need for relationship with other people is one of the strongest and most constant of human drives. Many research studies have indicated that the employees who have no opportunity for close social contacts find their work unsatisfying and this lack of satisfaction often reflects itself in low productivity and high rate of absenteeism and turnover. Elton Mayo observed that the employees in a textile plant who worked on isolated jobs were highly dissatisfied and consistently failed to meet production standards and staggered rest period helped a little. But when the company permitted these workers to take rest period as a group, production and satisfaction both increased.

**Sense of identification.** Workers get identity in small groups and so small groups tend to enjoy high morale. Employees working in large departments where everybody does the same type of job, find it hard to form stable social groupings compared to those working in small groups.

**Source of Information.** Informal group is a source of information to its members. Informal communication is very fast. A piece of information available to a member will reach nearly all the members of the group instantly. The group may develop a special code or language for speedy communication. Psychological barriers to communication are also overcome by the group.

**Job satisfaction.** The group's solution to a problem may be different from what management expects and it may even be more efficient. Shortcuts are evolved and informal channels of communication are established to cut across department boundaries. Many jobs which appear superficially dull and routine are made interesting by the group and spontaneity is encouraged and protected by the group.

Protection of members. Groups help protect their members from outside pressures. Groups often resist management's demands for additional output, increased working hours, and higher quality. Group members often agree on the level of output that each will put forth so that no member may outperform the others.

**Outlet for frustration.** An individual at times, feels tremendous stress in life and gets frustrated. If he shares his feelings and anxieties with someone, his tension is released to a great extent. The social relations provide

an important outlet for frustration. An informal group serves as a safety valve which helps release tension and frustration and checks the mental breakdown of the individual.

**Perpetuation of cultural values.** Sometimes, groups are formed by individuals belonging to a common cultural background. Such people can preserve their cultural identity and also feel a sense of security by associating with those pursuing the same cultural values and social norms. Maintenance of cultural values will also provide them psychological satisfaction.

**Generation of new ideas.** Informal groups are a breeding ground for new ideas as they provide a supportive environment in which the members can engage themselves in creative thinking. New product teams, task force, quality circles, etc. are important examples in this regard.

### **Importance of Small Groups to the Organisation**

***Filling in gaps in manager's abilities:*** Informal organization may act to fill in gaps in a manager's abilities. For example, if a manager is weak in planning, one of his subordinate may help him informally in such a situation. Solving work problems: Informal organization helps in solving the work problems of members. It allows them sharing job knowledge and taking decisions which affect a number of jobs.

***Better coordination:*** Informal groups evolve short-cuts and eliminate red tapism. They facilitate smooth flow of information and quick decision making. All these ensure better coordination among various individuals and departments.

***Channel communication:*** Informal groups act to fill up the communication gaps which arise in the organization. Informal communication cuts across the hierarchical and departmental boundaries and transmits information with greater speed. Informal communication can be of great use to the organization, if it is handled by the management properly.

***Restrain managers:*** Informal groups do not allow the managers to cross their limits. They restrict them from acquiring unlimited power and from using their power injudiciously.

***Better relations:*** A manager can build better relations with his subordinate through informal contacts. He can consult the informal leaders and seek their cooperation in getting the things done from the workers.

***Norms of behavior:*** Informal groups develop certain norms of behaviour which differentiate between good and bad conduct and between legitimate and illegitimate activities. These bring discipline and order among



the employees.

***Satisfied workforce:*** Cohesive informal groups provide satisfaction to the workers. As a result, labour turnover and absenteeism are reduced and organization's productivity is increased.

***Developing future executives:*** Informal groups recognize talented workers as their leaders. Such leaders can be picked up by the management to fill vacancies at the junior executive level in the future.

### **Problems Created by Informal Groups**

***Negative attitude of informal leaders:*** The informal leaders may turn out to be a troublemaker for the organization. In order to increase his influence, he may work against the policies of management and manipulate the behavior of his followers. Thus, he can be a source of conflict between the management and the workers. He may induce the followers to work against the interests of the organization. If such a leader is promoted to the rank of an executive, he may turn out to be a work shirker and an arrogant and autocratic boss.

***Conformity:*** The informal group exerts strong pressure on its members for conformity. The members may become so loyal to their group that following the group norms becomes a part of their life. This implies that members become subject to willful control of the group leader who may lead the group towards selfish ends.

***Resistance to change:*** Informal group generally have a tendency to resist change. Change requires group members to make new adjustments and acquire new skills. But groups want to maintain status quo. Sometimes, groups react violently to the proposed changes being brought by the management

***Rumor:*** Informal communication may give rise to rumors. This is not desirable from organization's point of view. Rumors originate for a number of reasons. Maliciousness, employee's anxiety and insecurity are the prominent reasons.

***Role Conflict:*** Every member of the informal group is also a member of the formal organization. Sometimes, there may be role conflict. In such a situation, group members may conform to their social norms. And if an individual member wants to follow the formal instructions of his boss, he may be snubbed by the informal leader and compelled to conform informal group norms.

## **Dealing with Informal Groups**

The management cannot wish away the existence of informal organization or groups. The only option left with management is to identify groups with their own dynamics, leadership, goals and cultural moorings and manage the same so that the informal organization aids management in the realization of organizational goals.

- A manager can build favorable relationships with informal leaders in several ways:
- He can consult the leaders and seek their advice on technical matters and human relationship problems
- He can request their assistance and cooperation in indoctrinating new members and training them to become competent workers in their job assignments
- Open, two-way communications can be encouraged on a continuous basis for mutual benefit
- A manager must be careful not to reduce the status of the leader in the eyes of his constituents, and especially careful not to show favoritism or partiality.

## **Review Questions**

1. Explain the various types of groups and how they are formed in the organizations.
2. Take a few examples of groups you are familiar with in your own operational area and explain their positive /negative contribution for the achievement group goals.
3. Present any one theory of group formation and examine its relevance to the present day organizations.
4. As a manager how do you take advantage of the groups in your department or division?

\*\*\*

---

## Lesson – 21 : Leadership

---

### Objectives

*After reading this lesson, you should be able to:*

- ▶ Understand Different Styles Of Leadership;
- ▶ Familiarize With Popular Theories On Leadership; And
- ▶ Adopt The Right Leadership Style Based On The Exigencies Of The Situation.

### Lesson Outline

- ▶ Meaning, Definition & Nature Of Leadership.
- ▶ Leadership Traits And Functions
- ▶ Managerial Skills Of A Leader
- ▶ Leadership & Management
- ▶ Theories Of Leadership
- ▶ Effectiveness Of Leadership
- ▶ Measures For Developing Leaders
- ▶ Review Questions

Leadership is a process of exercising influence over an individual or a group. Effective leadership is necessary for inspiring the people to work for the accomplishment of objectives. It provides a cohesive force which holds the group intact and develops a spirit of cooperation. Chester Bernard viewed leadership as the quality of behavior of individuals whereby they guide people and their activities. A leader interprets the objectives of the people working under him and guides them towards achievement of those objectives. He also creates and sustains enthusiasm among them for superior performance. In the words of Louis A. Allen, “*A leader is one who guides and directs other people. He gives the efforts of his followers a direction and purpose by influencing their behavior*”. Managers at all levels must perform leadership function in order to lead the subordinates towards organizational goals.

Leadership is the process of influencing the subordinates so that they cooperate enthusiastically in the achievement of group goals. In other words, leadership is the process by which an executive imaginatively directs, guides, and influences the work of others in choosing and attaining specified goals by mediating between the individuals and the organization in such a manner that both will obtain maximum satisfaction.

## Characteristics of Leadership

An analysis of the above definitions reveals that leadership as a managerial process has the following characteristics:

1. **Leadership is a process of influence:** Leadership is a process whose important ingredient is the influence exercised by the leader on the group members. A person is said to have an influence over others when they are willing to carry out his wishes and accept his advice, guidance and direction. Successful leaders are able to influence the behavior, attitudes and beliefs of their followers.
2. **Leadership is related to a situation:** When we talk to leadership, it is always related to a particular situation at a given point of time and under a specific set of circumstances. That means leadership styles will be different under different circumstances. At one point of time, the subordinates may accept the autocratic behavior of the leader while at a different point of time and under a different situation participative leadership style may be successful.
3. **Leadership is the function of stimulation:** Leadership is the function of motivating people to strive willingly to attain organizational objectives. Leaders are considered successful when they are able to subordinate the individual interests of the employees to the general interests of the organization. A successful leader allows his subordinates to have their individual goals set up by themselves in such a way that they do not conflict with the organizational objectives.

## Styles of Leadership

Leadership style refers to a leader's behavior. Behavioral pattern which the leader reflects in his role as a leader is often described as the style of leadership. Leadership style is the result of leader's philosophy, personality, experience, and value system. It also depends upon the types of followers and the organizational atmosphere prevailing in the enterprise.

### Different types of leadership styles are:

- i. Autocratic leadership;
- ii. Participative leadership;
- iii. Free rein leadership; and
- iv. Paternalistic leadership.

#### i. Autocratic or Authoritarian Leadership

The autocratic leader gives orders which must be obeyed by the subordinates. He determines policies for the group without consulting them and does not give detailed information about future plans, but simply tells the group what immediate steps they must take. He gives personal praise

or criticism to each member on his own initiative and remains aloof from the group for the major part of the time. Thus, under this style, all decision-making power is centralized in the leader. Leader adopting this style stresses his prerogative to decide and order and subordinates' obligation to do what they are told to carry out.

Autocratic leadership may be negative because followers are uniformed, insecure and afraid of leader's authority. Such a leader may be called the **strict autocrat** who realizes on negative influences and gives orders which the subordinates must accept. Leadership can be positive also because the leader may use his power to disperse rewards to his group. When his motivational style is positive, he is often called a benevolent autocrat. The **benevolent autocrat** is effective in getting high productivity in many situations and he can develop effective human relationships. There is another type of autocratic leader known as manipulative autocrat, who makes the subordinates feel that they are participating in decision-making process even though he has already taken the decision. An autocratic leader assumes that people basically work for money they and want security. Because of such assumptions about human beings, he exercises tight control and supervision over his subordinates. But these assumptions do not hold good in all the situations. If the motivational style is negative, people will dislike it. Frustration, low morale and conflict develop easily in autocratic situations.

## **ii. Participative or Democratic Leadership**

A democratic leader is one who gives instructions only after consulting the group. He sees to it that policies are worked out in group discussions and with the acceptance of the group. Participative manager decentralizes managerial authority. His decisions are not unilateral like that of the autocratic leader. Unlike an autocratic manager who controls through the authority, a participative manager exercises control mostly by using forces within the group. Some of the advantages of participative leadership are:

- It increases the acceptance of management's ideas.
- It improves the attitude of employees towards their jobs and the organization.
- It increases the cooperation between management and employees.
- It leads to reduction in the number of complaints and grievances.
- It increases the morale of the employees.

## **iii. Free Rein or Laissez Faire Leadership**

A free rein leader does not lead, but leaves the group entirely to itself. The free rein leader avoids power. He depends largely upon the group to establish its own goals and work out its own problems. Group members work themselves and provide their own motivation. The leader completely abdicates his leadership position by giving most of the work entrusted to him

to the group which he is supposed to lead. This is also known as permissive style of leadership, where there is least intervention by the leader. Abdication of authority by the leader and letting the group to operate entirely on its own are the common features of this style. This mode of direction can produce good and quick results if the subordinates are highly educated, responsible and brilliant who have a strong desire and commitment to give their best to the organization.

#### **iv. Paternalistic Leadership**

In this style, the leader assumes that his function is paternal or fatherly. His attitude is that of treating the relationship between the leader and his group as that of family with the leader as the head of family. He works to help, guide, protect, and keep his followers happily working together as members of a family. He provides them with good working conditions, fringe benefits and employee services. This style has been successful, particularly in Japan because of its cultural background. It is said that employees under such leadership will work harder out of gratitude.

### **Likert's Management Systems and Leadership**

Rensis Likert and his associates of the University of Michigan, had conducted extensive survey of management and leadership patterns in a large number of organizations. Within the basic style categories of task orientation and employee orientation, Likert developed a four level model of leadership effectiveness. These patterns of leadership are termed Systems of management and are assigned numbers from 1 to 4 to indicate the stages of evolution in the patterns of management in terms of leadership styles :

- System 1 – Exploitative authoritative
- System 2 – Benevolent authoritative
- System 3 – Consultative
- System 4 – Participative (Democratic)

SA brief description of these systems is given below:

#### **System 1 - Management**

System 1 managers make all the work – related decisions, and order their subordinates to carry them out. Standards and methods of performance are also set by the managers. The communication between the managers and the subordinates is highly formal in nature and downward in direction. The subordinates have absolutely no say in any matter in the organization. Such managers are highly autocratic who believe in threats and punishment to get the things done. They follow strict supervision over their subordinates.

## **System 2 - Management**

Managers under this system are also autocratic, but they are not fully authoritative. At times, they give some flexibility to the subordinates to carry out their tasks within the prescribed limits. Subordinates who meet or exceed their goals may be rewarded. Managers adopt patronizing or paternalistic attitude towards the obedient and faithful subordinates. They are very harsh with the subordinates who do not carry out the tasks.

## **System 3 - Management**

Under this system, managers set goals and issue general orders after discussing them with the subordinates. They take only major decisions and leave the routine decisions to be taken by the subordinates. Subordinates are free to discuss the work-related matters with their superiors. Thus, there exists a two-way communication in the organization. The control system tends to be flexible and goal oriented. More emphasis is placed on rewards than on punishments to motivate the subordinates.

## **System 4 - Management**

This is an ideal system towards which organizations should work. The relations between managers and subordinates are cordial and friendly. The communication system is completely open. The goals are set and work related decisions are taken by the subordinates. Group approach is adopted in supervision and control. Thus, system 4 presents true democratic styles of leadership. The managers are very supportive in their attitude towards the subordinates. Performance standards are mutually set by the superior and subordinates. They permit self – appraisal by the subordinates.

Likert sought to measure and evaluate the actual patterns of management in a wide range of organizations within the frame work of his four systems. He found that most individual managers and organizations fit into one or the other in terms of certain operating characteristics related to such variables as goal setting, decision making, communication, and control. Likert also sought to relate his systems of management with certain performance characteristics like productivity, quality, wastage, and employee turnover and absenteeism. He found that organizations with System 1 orientation scored very poorly while those oriented with System 4 scored creditably on these performance characteristics. He strongly recommended System 4 and regarded it as the best way to develop and utilize human assets of the organization. Likert also found many managers and organizations operating in System 2 and 3. For such organizations, he suggested extensive and intensive leadership training at all levels of management so as to move into System 4 – management.

## **Trait Theory of Leadership**

Trait theory seeks to determine universal personal characteristics of effective leaders. Numerous physical, mental, and personality traits were researched during the period from 1930 to 1950. Leaders were characterized by a wide variety of traits ranging all the way from neatness to nobility. In the late 1940s, Ralph Stogdill reported on the basis of at least fifteen studies that leaders possess intelligence, scholarship, dependability in exercising responsibilities, activity and social participation and socio-economic status. He also found traits such as sociability, persistence, initiative, knowing how to get things done, self confidence, alertness, insight, cooperativeness, popularity, adaptability and verbal facility in ten leadership studies. Persons who are leaders are presumed to display better judgment and engage themselves in social activities. The study of the lives of successful leaders reveals that they possessed many of these traits.

Trait studies have not produced clear results because they do not consider the whole leadership environment. Personal traits are only a part of the whole environment. Though a certain trait exists, it will not become active until a certain situation calls for it. Thus, there is no sure connection between traits and leadership acts. Leadership is always related to a particular situation. A person may prove successful in one situation due to some traits, but may fail in another situation.

Another shortcoming of the trait theory is the failure of its supporters to formulate a common list of traits found in all successful leaders. For instance, good health is desirable in many leadership situations, but there are also successful leaders in other situations that do not enjoy good health. There are so many exceptions to any general statement about leadership traits. The theory also fails to mention the traits which are necessary to maintain leadership. Measurement of a trait usually occurs after a person becomes a leader and it is difficult to suggest the traits which are pre- requisites of successful leader.

## **Behavioural Theory of Leadership**

Success in leadership depends more on what the leader does than on his traits. The behavioural approach is based on the premise that effective leadership is the result of effective role behavior. There is a dynamic interaction between the leader and the followers, and leaders produce different styles while dealing with the workers.

Many behavioural scientists have attempted to identify appropriate behavioural patterns of leadership styles. Some of the important contributions in this regard include Ohio State Studies, Michigan University Studies and Managerial Grid of Blake and Mouton. The behavioural scientists don't concentrate on the traits of leaders; rather they study the activities of leaders to identify their behavioural patterns.



## **Michigan Studies**

The Institute for Social Research at the University of Michigan conducted empirical studies to identify styles of leader behavior that results in higher performance and satisfaction of a group. The studies identified two distinct styles of leadership.

### **Employee Centred leadership and Production Centred (task oriented) leadership:**

The employee centred leaders concentrate on human relations and emphasize delegation of authority, concern for employee needs, welfare, advancement, etc. Leaders who are described as employee oriented stress the relationship aspects of the job. They feel that every employee is important and take interest in everyone, accepting their individuality and personal needs. Production centred leadership is more concerned with maximizing regardless of the employees needs, welfare and aspirations. Managers don't attach much importance to the human element.

The Michigan Studies found that both the styles of leadership led to increase in production, but it was slightly more in case of production centred style. However, the use of direct pressure and close supervision led to decreased satisfaction and increased turnover and absenteeism. The employee centred approach led to improved work flow and more cohesion in interactions resulting in increased satisfaction and decreased turnover and absenteeism. This suggested the superiority of the employee centred leadership style over the production centred style.

### **Evaluation of Michigan Studies**

The value of Michigan studies lies in the analysis of two leadership styles, task and employee oriented leadership. Instead of restricting to traits of leaders, they concentrated on the behavior of leaders. These studies are criticized on the following grounds:

- i. The Michigan studies failed to suggest whether leader behavior is a cause or effect. They did not clarify whether the employee centred leadership makes the group productive or whether the highly productive group induces the leader to be employee centred.
- ii. The Michigan Studies did not consider the nature of the subordinates' tasks or their personal characteristics. Group characteristics and other situational variables were also ignored.
- iii. The behavioural styles suggested by Michigan Studies have been termed as static. A leader is supposed to follow either of the two styles, viz., task orientation and employee orientation. But in practice, a particular style may succeed in one situation and fail in another. Moreover, leaders don't restrict themselves to a particular

style. They adopt both the orientations in varying degrees to suit the particular situation.

### Ohio State Leadership Studies

The leadership studies initiated by the Bureau of Research at Ohio State University attempted to identify various dimensions of leader behavior.

**Chart : OHIO STUDIES: LEADERSHIP**

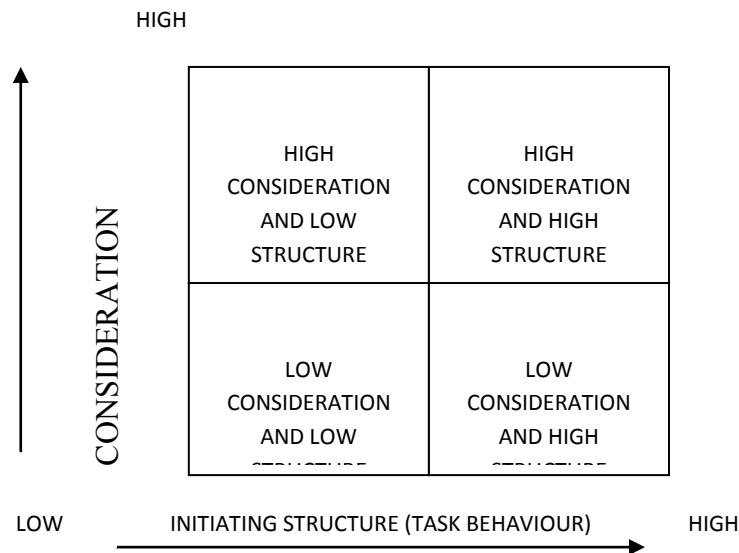

**Figure 21.1: Ohio Studies - Leadership**

Ultimately, these studies narrowed down to the identification of two dimensions of leader behavior: *Initiating Structure and Consideration*.

**Initiating Structure** refers to the leader’s behavior in delineating the relationship between himself and members of the work group and of communication, and methods or procedures. On the other hand, **Consideration** refers to the leader’s behavior indicative of friendship, mutual trust, respect, and warmth in the relationship between the leader and the members of his staff. The research studies also showed that initiating structure and consideration are two distinct dimensions and not mutually exclusive. A low score on one does not require high score on the other. Thus, leadership behavior can be plotted on two separate axes rather than on a single continuum. The four quadrants in Fig. 16.1 show various combinations of initiating structure and consideration. In each quadrant, there is a relative mixture of initiating structure and consideration and a manager can adopt any one style.

## Managerial Grid

The two dimensions of leadership, viz. *concern for people and concern for production* have been demonstrated by Robert R. Blake and James S. Mouton in the form of a grid. The word 'Grid' means an iron grating, a frame work of parallel bars.

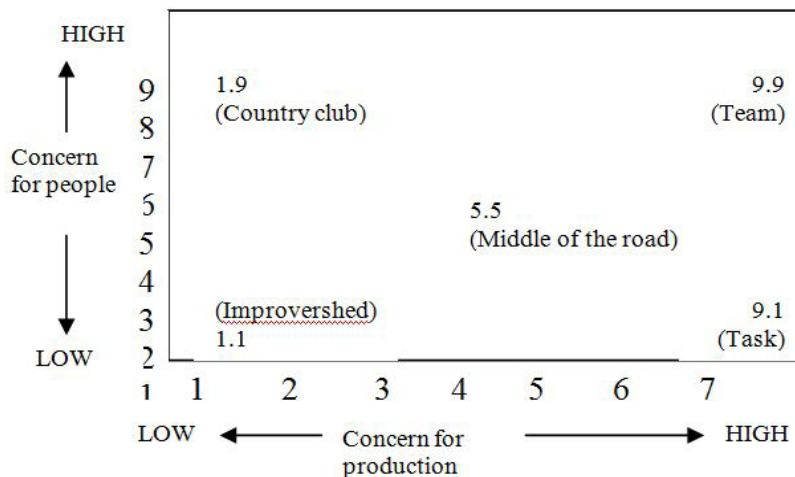

**Figure 21.2: Managerial Grid**

Blake and Mouton identified five basic leadership styles of practicing managers representing various combinations of the aforesaid two dimensions as shown in the above diagram. It is, however, important to point out these basic styles are a matter of convenience rather than a fact. A brief description of these styles is given below.

### 1. The 9, 1 managerial Style (Task)

People are regarded as an instrument of production under the 9, 1 management style. It is an autocratic style of leadership. This style places a heavy emphasis on task and job requirement. Human relationships and interactions are minimized. Subordinates are expected to carry out orders with an unquestioning obedience. They are taken as merely means for doing the tasks assigned to them. Little attention is given to their development or communicating with them beyond the issue of instructions and orders. If there is a conflict between a subordinate and the boss, the goal of the boss is to win.

### 2. The 1, 9 Managerial style (Country Club)

Under this style of management, work is done leisurely. At best people are regarded rather than driven. Subordinates are expected to turn out some work to avoid trouble. The boss is more of a big brother rather than an autocratic leader. Social relationships are more important. The group, not the individual is the key in the organization. The aim is to achieve friendliness and harmony among the members of the organization.

### **3. The 1, 1 Managerial Style (Impoverished)**

A manager with this orientation exerts minimum influence on the contacts with group members. He expresses little concern for production or people. In a supervisory position, he is most likely to be found executing messenger – carrier functions, communicating orders from the layer above to the layer below. He is an expert in passing on blame to others for failures in such a way that he absolves himself from responsibilities and rarely initiates. His criticism is strictly in self defense. Minimum involvement in organization's purpose and with its people is all that he wants. Through minimum contact and non- involvement, the 1, 1 style reduces the need to take active steps with respect to managerial responsibilities. Subordinates or members of the group are left to find for themselves the ways of doing the job.

### **4. The 5, 5 managerial Style (Middle Road)**

The “people” dimension in the work situation is as important as the “production” dimension. The 5, 5 style seeks to maintain a balance between the two. A basic assumption of this style is that people will work willingly and they are told the reasons for doing so are explained to them. However, just enough is communicated so that people have a general sense of what is going on. If too much is told, it is feared that they might resist. Enough concern is shown for the people so that adequate production may be achieved. This is seen in the 5, 5 approach to management development, communication, and performance reviews. Meetings are held to listen to their suggestions and to create a sense of participation in decision - making.

### **5. The 9, 9 Managerial Style (Team)**

A major difference between 9, 9 style and other managerial styles is in goal setting and its use as a basic management approach to a large variety of problems. The capability of people in achieving organizational objectives through commitment is fundamental. In other words, the 9, 9 orientation aims at integrating the people and production dimensions of work under conditions of high concern for growth. The key is the involvement and participation of those responsible for it in planning and execution of work. This brings about the kind of team spirit that leads to high organization accomplishment.

Each of the five styles given by Blake and Mouton points out the relative concern for production and people and implies that the most desirable leadership behavior is 9, 9 i.e., maximum concern for both production and people. It may be noted that the five positions emphasized in the Managerial grid are rarely found in their pure form in actual life. That means, a manager may have a style of 8, 2, or 4, 6 or some other. Nevertheless, Managerial Grid is widely used as a technique of managerial training and for identifying various combinations of leadership styles.

In essence, the managerial Grid has given popular terminology to leadership styles within the four quadrants of the Ohio State Studies. However, there is one basic difference between the two. In managerial Grid, ‘concern for’ is a predisposition about something or an attitudinal dimension.

Thus, managerial Grid tends to be an attitudinal model that measures the predispositions of a behavioural model that examines how leader actions are perceived by others.

### **Choice of Leadership Style**

We have observed that different management experts have suggested different styles and there is no unanimity among them as to which is the most suitable for an enterprise. For example Rensis Likert suggested democratic leadership. As different leadership styles have their merits and demerits, it is difficult to prefer one leadership style to another. The selection of a leadership style will depend on the consideration of a number of factors. According to Tannenbaum and Schmidt, the important factors that affect the choice of a style of leadership are as follows:

**Forces in the Manager** : These include manager's personality, experience, and value system, his confidence in subordinates, leadership inclination, feeling of security in an uncertain situation, etc.

**Forces in the Subordinates** : These include readiness of subordinates to assume responsibility for making decisions, need of subordinates for independence, interest in the problem at hand, knowledge to deal with the problem, etc.

### **Situational Theory of Leadership**

This theory advocates that leadership is strongly affected by the situation from which a leader emerges and in which he works. It is based on the assumptions that there exists an interaction between a group and its leader and that people tend to follow the person (known as leader) who is capable of fulfilling their aspirations. Thus, leader is a means of achieving the goals of the group and the members. The leader recognizes the needs of the situation and then acts accordingly.

The focus in the situational approach to leadership is on observed behavior and not on any hypothetical inborn or acquired ability or potential for leadership. In other words, the emphasis is on the behavior of the leaders and their followers and the type of situation. In other words, a person becomes a leader not only because of his personal attributes, but also because of various situational factors and the interactions between the leader and the group members.

### **Review Questions**

1. What is leadership? Discuss the trait and situation theory of leadership.
2. "Leadership is situational." Comment on the statement.
3. "Leaders are born and not made". Discuss

4. “A good leader is one who understands his subordinates, their needs and their sources of satisfaction.” Comment.
5. Critically examine the different approaches to the study of the leadership behavior. Is there one best style of leadership?

### **Case Study**

#### **New Boss and his Leadership Style**

For Several months employees of a large corporation have been very dissatisfied with the new division head. Before the arrival of the new division head, the department had functioned as a cohesive, effective unit, combining hard work with equal amount of leisure. The new division head has very strong idea about the types of environment his employees should have. As one supervisor puts it, it resembles a full scale military operation. No longer are occasional informal gatherings during office hours. The bottom line has become productivity first, with the employees’ feelings being considered as an afterthought. Grass-root employees as well as supervisory personnel are very upset about the changes in structure, and their dissatisfaction is beginning to show up in their performances. Because of the decreased productivity levels, the supervisors have been informed that if they don’t shape up their subordinates, “the axe will fall on several heads”. The frustration and anger is now beginning to come to a full boil and the supervisors have decided to meet to discuss the situation.

### **Questions**

- a. Identify the leadership style of the division head from the angle of Managerial Grid.
- b. From the view point of theory of X and Y, what assumption did the new head make about the way in which people work most effectively?

\*\*\*

---

## Lesson - 22 : Organisational Power & Politics

---

### Objectives

*After reading this lesson, you should be able to:*

- ▶ Appreciate The Importance Of Power In The Organizational Context;
- ▶ Distinguish Power From Authority And Influence;
- ▶ Identify Sources Of Organisational Power And Its Uses; And
- ▶ Relate Power To Organisational Politics.

### Lesson Outline

- ▶ Characteristics Of Power
- ▶ Sources Of Power
- ▶ Uses Or Bases Of Organisational Power
- ▶ Power Dynamics In Organisations
- ▶ Review Questions

This lesson first defines power and distinguishes it from authority. Then it identifies sources of power and explains how power is used in organisations. Finally, it presents the political perspective of power in today's organisations. The underlying premise of this lesson is that acquisition. Power is a determinant of goals to be achieved and of how resources will be distributed. These, in turn, have far reaching implications for organisation members' performance, satisfaction and organisational effectiveness.

There is no universally accepted meaning of power. Power has more diverse meanings than any other concept in organisational behaviour. In general, it refers to a capacity that one has to influence the behaviour of another so that the other person does something which would not be done otherwise.

However, few of the definitions on power are presented here to capture the wide range of the meanings it has assumed over a period of time.

The earliest definition of power is one given by **Max Weber**, the famous Sociologist. He defines power as "the probability that one actor within a social relationship will be in a position to carry out his own will despite resistance".

Another definition of power refers it to the ability to get things done despite the will and resistance of others or the ability to win political fights and outmaneuver the opposition.

Pfeiffer, an organizational behavior theorist, defines power as " *the*

*ability to influence behaviour, to change the course of events, to overcome resistance, and to get people to do things that they would not otherwise do ”.*

## **Characteristics of Power**

Definitions of power are related to the concepts of authority and influence. Chester Barnard defined power as “informal authority”. Many modern organisational sociologists define authority as “legitimate power”. To have better understanding of power, we bring out clearly the distinctions between power and authority and power and influence.

## **Power – Authority Distinctions**

From the preceding discussion, it is clear that a person who possesses power has the ability to manipulate or influence others. Authority legitimizes and is a source of power in the organisation. In contrast, power need not be legitimate. Distinction can be made between top-down classical, bureaucratic authority and Barnard’s acceptance theory of authority. To him, authority is “the character of a communication (order) in a formal organisation by virtue of which it is accepted by a member of the organisation as governing the action he contributes”. Power is different from such acceptance theory of the authority in the words of Grimes who notes: “what legitimizes authority is the promotion of pursuit of collective goals that are associated with group consensus”.

## **Power- Influence Distinction**

Influence is broader than power in its scope. It is a process of affecting the potential behaviour of others. Power is the capacity of influence. Thus, authority is different from power because of former’s legitimacy and acceptance, and influence, though broader than power, is closer to it conceptually. Hence, both are interchangeably used.

## **Sources of Organisational Power**

French and Raven’s Classification of sources of power includes reward power, coercive power, legitimate power, referent power and expert power. But sources of power are different from power bases. This distinction is not maintained by French and Raven. How power holders control power bases speaks about sources of power. In other words, sources of power tell us wherefrom the power holders get their power bases. There are four sources of power, namely, *position power* (legitimate power), *referent power* (personal powers), *expert power* and *opportunity power*.



## **Position Power**

The source of position power is almost identical to authority. One's structural position in the formal group or organisation enables access to power bases i.e., what the power holder has that gives him power. According to French and Raven this power stems from the internalized values of the other persons which give legitimate right to the power holder to influence them. In other words, others feel that they have obligation to accept this power. Again there are three major source of legitimate power.

- *One* is prevailing cultural values of organisation or group which determine legitimacy. In organisational context, managers have legitimate power because employees believe in private property laws and in the hierarchy where persons holding higher positions wield power over lower position holders.
- *Second* source of legitimacy is social structure. In an organisation, for example, when blue collar workers accept employment, they are in effect accepting its hierarchical structure and thereby granting legitimate power to their superiors.
- Being designated as the representative of a powerful person or a group is a third source of legitimate power. A member of the board of directors or management committee is examples of this source. These sources of legitimate power create an obligation to accept and be influenced.

## **Personal Power or Referent Power**

One's personal characteristics can be a source of power. Articulation, domineering and charisma are personal characteristics that yield personal power. Others want to identify with a powerful person, regardless of consequences. In the organisational setting, a manager who depends on referent power must be personally attractive to his subordinates.

## **Expert Power**

Expertise is the means by which the power holder controls specialized information. Others attribute knowledge and expertise to the power seeker. In a technology-oriented or knowledge society, expert power is one of the most powerful sources of influence. Credibility comes from having the right credentials, that is, the person must really know what he is talking about and be able to show tangible evidence of knowledge. Besides credibility, the person holding expert power must be trustworthy, that is, he must have reputation for being honest and straightforward.

## **Opportunity Power**

Being in the right place at the right time can give a person the opportunity to gain power. One need not hold a formal position in an organisation to have access to information which others value most.

## **Other Sources of Power**

Besides these four sources of power, there is yet another source arising out of task-interdependence. Though a superior has legitimate power over subordinate, he must depend on the subordinate to get the job done correctly and on time. Hence the latter has power over the former due to task interdependency.

## **Bases of Organisational Power**

### **Coercive Power**

The coercive power depends on fear. The person with the coercive power has the ability to inflict punishment or adverse consequences on the other person. One reacts to this power out of fear of the negative ramifications that might result from non-compliance. In the organisational context, managers frequently exercise coercive power as revealed from their actions such as dismissing, suspending or demoting their subordinates or withholding pay increases. In other words, managers control through force or hitting at the basic physiological or safety needs. Here it is to be noted that protective labour legislation and trade unions have stripped away some of this coercive power of managers.

### **Reward Power**

Reward power is the opposite of coercive power. People comply with the wishes of another because it will result in positive benefits. The type of rewards includes material rewards like pay increase, fringe benefits, commissions, etc. Managers exercise this power since they have ability and resources to reward their subordinates. The strength of the reward power depends on whether the subordinates look at rewards offered to them as rewards or otherwise. Managers may offer what they think as rewards, but subordinates may not value them. The reverse may also be true.

### **Persuasive Power**

This use of power rests on the allocation and manipulation of symbolic rewards. If a person can decide who is hired, control the allocation of resources, or influence group norms, he is said to have persuasive power. A few common symbols of manager's power in the organisation include: getting a favorable placement for a talented subordinate, getting approvals for expenditures beyond budget, getting items on agenda at policy meetings, getting fast access

to top decision makers, getting early information about decisions and policy shifts, getting above-average salary increases for subordinates, etc.

### **Knowledge Power**

Knowledge or access to information is the final use or base of power. When an individual in a group or organisation controls unique information needed to make decisions, then he processes knowledge-based power.

### **Influenceability of Targets of Power**

So far our discussion has confirmed the unilateral influence of power from the agent (power holder) to targets (other persons). Power relationship as a reciprocal relationship can be better understood by focusing attention on characteristics of targets. Influenceability of targets depends on the following:

#### **Dependency**

Power is a function of dependency. The general dependence postulates that the greater the dependency of the target on the agent, the greater the power the agent has over the target. Dependency increases when the resources controlled by the agent are important, scarce and non-substitutable. The scarcity - dependency relationship can be clearly seen in occupational groups where supply of skills is low relative to demand for them.

#### **Uncertainty**

When people have a feeling of uncertainty about the correctness of their behaviour, they are more susceptible to influence.

#### **Personality**

Persons with personality characters like low tolerance for ambiguity and high anxiety (fear of failure) are more likely to be influenced.

#### **Intelligence**

Relationship between intelligence and influenceability is complex. In some cases it is positive whereas in other cases negative, since highly intelligent people being held in high esteem may resist being influenced.

#### **Gender**

It is traditionally believed that women are more likely to be influenced than men, because of the way the former are brought up. As the role of women is fast changing and they are more empowered now, there is a perceptible change, of late.

## **Culture**

Western cultures that emphasize individuality, dissent and diversity tend to decrease influenceability whereas Asian cultures that emphasize cohesiveness, agreement and uniformity promote influenceability.

## **Contingency Model of Power**

According to this model, target will comply to gain or avoid punishment. In order to gain compliance to work, the superiors must be able to reward and punish subordinates and keep surveillance over them. But the agent must have referent power, that is, very attractive to the target. The agent must also be in the forefront of targets awareness. People will internalise because of compatibility with their own value structure. For people to internalize the agent must have expert or legitimate power and be relevant. Internalized power has a lasting impact.

## **Power Tactics**

Let us understand how employees in organisations translate their power bases into specific actions. Findings of research on managers identified seven power tactics:

- i. reason;
- ii. friendliness
- iii. collation (getting the support of other people in the organisation to back up the support);
- iv. bargaining (negotiations for exchange of favours);
- v. assertiveness;
- vi. higher authority (gaining the support of higher levels in the organisation to back up requests);
- vii. sanctions (using organizationally derived rewards and punishments).

Manager's relative power in the organisation determines tactics selection. They also change their tactics depending upon their objectives in the upward and downward influences. Choice of tactics depends upon expectations of success. Assertiveness and sanctions are used when success is less predictable. Different cultures prevalent in the organisation also have significant bearing on the choice of power tactics.

## **Power Dynamics in Organisations**

Power dynamics in organisation relate to political realities of power acquisition in organisations and the specific political strategies in power acquisition.

## **Political Behaviour**

One perspective of political behaviour is, large organisations are like governments in the sense that they are fundamentally political entities. Political behaviour in the organisation refers to those activities not required by one's formal role definition in the organisation. Political perspective of organisation departs from the classical idealistic, rational organization. Four postulates of power by Walter Nod focus on political realities in the organisation. *One*, organisations are composed of competing coalitions. *Second*, various coalitions seek to protect their interests and positions. *Third*, unequal power distribution has dehumanizing effect. Fourth, exercising power within organisation.

## **Factors Contributing to Political Behaviour**

Individual and organisational factors can increase political behaviour and provide favourable outcomes (rewards and averted punishments).

### **Individual Factors**

High self-monitors being sensitive to social cues and social conformity, are more skillful in political behaviour than low self-monitors. Individuals with internal locus of control (those who believe they can control their environment) are proactive and manipulate situations in their favour. A person having high expectation of increased future benefits will lose if forced out; hence he is more likely to use illegitimate means (extreme political behaviour). More alternative job opportunities a person has, more likely he is to use legitimate means (normal every day politics).

### **Organisational Factors**

#### *(i) Resources*

Degree of politics, criticality and scarcity of resources in organisation are directly related. Politics surface when the resources are declining and their existing pattern is changing. Infusion of new and unclaimed resources will lead to high political behaviour.

#### *(ii) Trust*

Low trust in organisation results in higher political behaviour, that too illegitimate type.

#### *(iii) Cultural Factors*

Role ambiguity (lack of clarity in role definition), ambiguous decisions and decisions on which there is a lack of agreement and uncertain, long range strategic decision, zero-sum reward allocation practices (one man's gain is other man's loss), democratic decision-making, performance evaluation systems and self-seeking senior managers, will be sources of conflicts and thereby high politicking. Higher the pressure on performance employees feel, the greater the likelihood of their resorting to politics.

(iv) *Technology and External Environment*

Complex technology and turbulent external environment lead to high political behaviour.

(v) *Change*

Planned organisation change or unplanned change brought about by external environment forces will encourage political behaviour.

### **Specific Political Strategies for Power Acquisition**

Organisational members adopt different strategies to acquire power. Durkin suggested strategies listed below help to gain deeper insights into power and politics in the organisations.

a. *Maintain alliance with powerful people*

Alliances with members of other important departments or of top management or with boss's secretary or staff assistant are critical to acquisition of power.

b. *Embrace or Demolish*

The guiding Machiavellian principle is that senior managers in the taken over firms should be welcomed and encouraged or sacked. To make them powerless it is better to sack them than to downgrade them. If downgraded, they combine and fight back.

c. *Divide and Rule*

This is a popular strategy based on the assumption though unwarranted, that persons divided will not themselves form coalition.

d. *Manipulate classified information*

Organisational members adept in politics control information so as to gain power.

e. *Make a quick showing*

Looking good on some project or task right at the beginning is to get the right people's attention. Once this positive attention is gained, power is acquired to do more difficult and long-range projects.

f. *Collect and Use IOUs*

Do favours to others with clear understanding that they should pay in return when asked.

g. *Avoid decisive engagement*

Also called Fabianism: Be slow, but sure to become entrenched and gain cooperation and trust of others.

h. *Progress one step at a time*

One small change can be a foothold for power seeker to use it as a basis to get other major things accomplished.

i. *Wait for a crisis*

It is based on the assumption things must get worse before they turn better. Crisis conditions bring more resources that facilitate tiding over crisis.

j. *Take Counsel with Caution*

This relates to how to retain power rather than how to acquire it. For example, prescriptions like participative management and empowerment are to be taken with caution as they erode the power base of managers.

## **Defensive Behaviour as a part of Organisational Politics**

Individuals in the organisation engage quite often in reactive and protective defensive behavior with the objective of avoiding action, balances or change. Each of the objectives of defensive behaviour is illustrated in the following lines.

### **Avoiding Action**

Here are six popular ways to avoid action.

- i. *Over conforming*  
Rigid Adherence to politics, rules and precedents to avoid action in a particular case.
- ii. *Buck Passing*  
Transferring responsibility for action or decision making to some one else in the organisation.
- iii. *Playing Dumb*  
False pleading of ignorance or inability to avoid an unwanted task.
- iv. *Depersonalisation*  
To avoid becoming personally involved, people are treated as objects and numbers. This distancing from them avoids problems and the need for considering their idiosyncrasies and impact of events on them.
- v. *Stretching and Smoothing*  
Stretching is prolonging task. Smoothing refers to covering up fluctuations in effort or output. Both are designs to give semblance of being busy and productive.
- vi. *Stalling*  
Being supportive publicly while doing little or nothing privately.

### **Avoiding Blame**

The following behaviours are intended to avoid blame, or actual or anticipated negative results.

- i. *Buffing*  
Documenting activity to projection image of competence and thoroughness
- ii. *Playing Safe*  
Taking only profitable projects, having risky decisions approved by superiors, qualifying judgements and taking neutral positions in conflict situations- all are to evade situations pregnant with unfavourable outcomes.
- iii. *Justifying*  
Developing explanations to minimize responsibility for negative result and/ or apologizing to demonstrate remorse.
- iv. *Scapegoating*

Shifting the blame for negative results on external factors.

v. *Misrepresenting*

Manipulating of information by distorting, embellishing and selectively representing it.

vi. *Escalation of Commitment* By throwing good money (additional resources) after bad money (poor decisions and failing courses of action) to demonstrate confidence in the past actions and consistency over time.

### **Avoiding change**

When people feel threatened by change they resort to the following behaviours

- i. *Resisting Change*: This is a catch-all phase under which many defensive behaviours are covered.
- ii. *Protecting Turf*: Fencing the job territory to avoid encroachment. Immediate consequence of defensive behaviours is reduced organisational effectiveness. Their long-term consequences are organisational stagnation, detachment from organisational environment, highly politicized organisational culture and low morale.

### **Review Questions**

1. Define Power, authority and influence.
2. Explain the importance of power and its characteristics?
3. How are sources of power different from bases of power? Illustrate with examples.
4. Describe power tactics.
5. Define organisational politics. What are its determinants?
6. Explain the defensive behaviours in organisational politics with their corresponding objectives.
7. Discuss strategies for acquisition of power in organisations.
8. What is contingency model of power?
9. From your over-all understanding of the working of power, authority and influence and general awareness, explain your understanding on the process of 'empowerment.'

\*\*\*



---

## Lesson - 23 : Organisational Structure, Climate And Culture

---

### Objectives

*After reading this lesson, you should be able to:*

- ▶ Understand The Concept Of Organizational Structure;
- ▶ Identify The Factors Determining Organizational Structure;
- ▶ Recall The Major Dimensions Of Organizational Climate; And
- ▶ Explain The Characteristics Of Organizational Culture.

### Lesson Outline

- ▶ Factors Determining Organizational Structure
- ▶ Bases Or Forms Of Departmentalization
- ▶ Horizontal & Vertical Dimension Of Organizational Structure
- ▶ Traditional, Modern, Commercial & Non Commercial Organizational Structure
- ▶ Major Dimensions Of Organizational Climate
- ▶ Meaning & Characteristics Of Organizational Culture
- ▶ Review Questions

Organizational structure provides the framework for managers and others for performing the various functions expected of them and for facilitating the work flow in the organisation. A sound structure facilitates performance. The managerial process of organising results in the creation of a formal organisational structure which is defined as a system of patterned and interrelated task units with well defined authority-responsibility relationships. It is called formal structure since it is deliberately and purposefully planned and designed by management. The formal organisational structure has two 'dimensions'. They are: *horizontal dimension* and *vertical dimension*.

The horizontal and vertical dimensions of the organisational structure, viz., the activity structure and authority structures are tied together. The managerial positions are not created in a vacuum; they are created around the sub-divided task units. Organisational goals, technology, external environment and the people in the organization greatly influence the design of the structure.

## **The Horizontal Dimension of Organisational Structure**

The horizontal dimension consists of the various activities or working units created through the process of departmentation and is called the activity structure. In a manufacturing enterprise, the activity structure consists of the various tasks or activity spheres. Departments like purchasing, production, R & D, human resources, accounts, marketing and so on are created by that logic..

**Departmentation:** The concept of departmentation, is one of the important steps in the design of formal structure of an organisation. Departmentation involves a systematic sub-division of activities into individual jobs, the grouping of jobs into work-units and the integration of units into departments. The departments so created have lateral relations to each other. Thus departmentation creates the lateral or horizontal activity structure of the organisation. There are several alternative ways in which organisational activities are grouped into work units. These are called the bases or forms of departmentation. The major bases or forms are: Function, process or equipment, product, customer and geographical area.

## **Vertical Dimension of Organisational Structure**

Authority is the formal right vested in a managerial position to undertake certain managerial tasks, to make decisions, to give directions to subordinates and to influence events for achieving certain goals. The concepts of authority, responsibility and accountability have particular relevance for understanding the process of delegation of authority. The concept of responsibility has two connotations. In one sense, it is the set of tasks or duties assigned to a person. In another sense, it is corollary of authority and is the obligation of a person to whom authority is delegated, to act in response to an order issued by his superior. Accountability is often used as a synonym to responsibility. In other words, accountability and responsibility have the same meaning. Some others, however, distinguish between accountability and responsibility by defining accountability as personal answerability for decisions, actions and results on the part of a subordinate to his superior. The vertical axis of the organisational structure thus consists of the hierarchy of management or the network of managerial authority levels. The hierarchy of management is established through the process of vertical differentiation and integration of authority.

## **Modern Organisational Structures**

Traditional structures are regarded as somewhat out of step with contemporary requirements and realities of rapid change, uncertainty and complexity of environment. Attempts are hence made to modify the traditional structures so as to evolve refined forms of structure. These are variously described as **systems structure, project structure, programme structure,**

**matrix structure, task force structure and free form structure.** These modern structures are regarded as more organic, adaptive, and flexible and are suitable for complex organisations which employ highly sophisticated technology and which encounter a very diverse and volatile environment.

## **Organisational Climate**

The term, 'Organisational climate' is defined as a relatively enduring quality of the internal environment of an organisation as perceived and experienced by its members, which can be described in terms of specific dimensions or characteristics and which influences the patterns of behaviour and work performance of members. It is the totality of interacting and inter-related internal dimensions or characteristics which significantly influence the motivation of members. Organisation climate evolves over a fairly long period of time and is relatively stable. Since the dimensions of climate are internal, they can be measured, controlled and changed by the organisation, if it so decides. Organisational climate is the major frame of reference for the member's interpretation of organisational decisions and actions as also their own attitudes, behaviour and performance.

**The major dimensions or characteristics of organisational climate are listed below:**

- Organisational values, goals and priorities which are pursued in practice as against those which are professed.
- Managerial value systems and life styles.
- Competence, character, commitment and dynamism of management.
- The complexion of organisational policies and practices and the consistency with which they are followed.
- The power structure - the extent of concentration or dispersal of authority, the extent to which and the manner in which formal authority is exercised, the extent of status disparities, social distance between managers at various levels and between managers and non-managers and so on.
- General organisational structure-hierarchy, rigidity vs. flexibility, clarity of the structure, communication and control systems, superior-subordinate relations, informal social relationships, etc.
- Nature of jobs – degree of skill required, relation between effort and productivity, variety in the tasks, perceived importance of the job, rewards associated with the job, relation with other jobs, security and so on.
- Degree of freedom and control – requirements of conformity and compliance to organisational norms and the extent to which behaviour of employees is structured.
- Supervisory style – attitudes and behaviour of supervisors and managers towards their subordinates and towards performance requirements.
- Reward structure – reward levels and interrelations, equity in reward

- structures, monetary and non-monetary rewards.
- Organisational approach to conflict and dissent, amicable resolution or suppression of conflict.
- The physical working conditions in the organisation.

### **Factors Affecting Organisational Climate**

Factors affecting organizational climate differ from organization to organization. In some organizations certain factors like structure, or process plays a major role and in some other organizations, technology might be the major factor influencing the climate. However the major factors, according to Lawrence James and Allan Jones affecting the organizational climate can be grouped under the following heads:

**Organizational content:** The reactions of the employees and the degree to which they welcome and accept the managerial philosophy is very crucial to the development of sound and favorable organizational climate. The climate is said to be highly favorable when the existing management techniques are such that employees goals are perfectly matched to the ideas of organizations.

**Structure:** Structure is the framework that establishes formal relationship and delineates authority and functional responsibility. It is generally believed that decentralized structure results in sound climate. In sharp contrast, if the management feels the necessity of maintaining greater degree of consistency in operations regarding decision-making, it will be wedded to centralized structure.

**Process:** In every organization certain processes are vital so that it functions. Communication, decision making, motivation and leadership are some of the important processes through which management achieves the tasks. For instance, if we consider leader-follower relationship, leadership process, it is leader's choice whether to allow subordinates in decision-making, give assignments, etc. A leader has to be aware of the possible influence of his actions on the climate while deciding about the most appropriate supervisory technique for a given situation. It should be noted that failure to give consideration to the effect on climate could cause great harm to the organization.

**Physical Environment:** the external conditions of environment, the size, location of the work place etc., will also affect organizational climate. An employee performing his job in relatively clean, quiet, safe environment will undoubtedly have a favorable perception of the organizational climate. Noise has also been considered instrumental in influencing the climate of an organizational.

**System Values and Norms:** Every organization has discernible and fairly formal value system where certain kinds of behaviors are rewarded and

encouraged and certain kinds of behavior forces an individual to formal sanctions. The formal value system is communicated to employees through rules, regulations and policies. But informal value system is very difficult to ascertain. But both exert influence on organizational climate.

In general, organisational climate provides certain stimuli, offers certain opportunities and raises certain expectations among its members; at the same time, it also creates certain constraints, threats, problems and frustrations. Organisational climate influences the perceived ability of the individual employee, which in turn has a decisive effect on his motivation. Perceived ability is influenced by the nature and clarity of the job, the scope of responsibility, degree of freedom, supervisory support and training, safety and other physical working conditions, previous experience and so on.

## **Organizational Culture**

Organizational culture is the set of assumptions, beliefs, values and norms that are shared by the members of an organization. It may be consciously created by its key members, or it may have simply evolved over time. It represents a key element of the work environment in which employees perform their jobs. A culture may exist across an entire organization, or it may refer to the environment within a single division, branch, plant, or department. The idea of organizational culture is somewhat intangible, for we cannot see it or touch it, but it is present and pervasive. Like the air in a room, it surrounds and affects everything that happens in an organization. Because it is a dynamic systems concept, culture is also affected by almost everything that occurs within an organization. They give an organizational identity to employees – a defining vision of what the organization represents. They are also an important source of stability and continuity to the organization which provides a sense of security to its members.

## **Characteristics of Cultures**

Each organization has its own history, patterns of communication, systems and procedures, mission statements and visions, stories and myths which, in their totality, constitute its distinctive culture. Cultures are also relatively stable in nature. Most organizational cultures have historically been rather implicit rather than explicit. A defining characteristic of most culture is that they are seen as symbolic representations of underlying beliefs and values.

## **Measuring Organizational Culture**

Systematic measurement and comparison of cultures is difficult. Most of the early attempts by researchers relied on examination of stories, symbols, rituals, and ceremonies to obtain clues. Others have used interviews and open ended questionnaires in an attempt to assess employee values and beliefs. In some cases, examination of corporate philosophy statements has provided insights into the espoused cultures (the beliefs and values that the organizations state

publicly). Another approach is to survey employees directly and seek their perceptions of the organization's culture. Another interesting method is to become a member of the organization and engage in participant observation.

### **Characteristics of organizational cultures**

- Distinctive
- Stable
- Implicit
- Symbolic
- Integrated
- Accepted
- A reflection of top management

### **Communicating Culture**

If organizations are to consciously create and manage their cultures, they must be able to communicate them to employees, especially the newly hired ones. Individuals are generally more willing to adapt when they want to please others, gain approval, and learn about their new work environment. These cultural communication acts may be lumped under the umbrella of organizational socialization, which is the continuous process of transmitting key elements of an organization's culture to its employees. Individualization occurs when employees successfully exert influence on the social system around them at work by challenging the culture or deviating from it.

### **Review Questions**

1. Describe the organisational culture that seems to exist in your organisation. What are some of the implicit or explicit norms, values and assumptions?
2. Discuss the bases or forms of departmentalisation in an organisation?
3. Explain various characteristics of Organisational Climate.
4. Distinguish between
  - a. Horizontal & Vertical dimension of organisational structure.
  - b. Commercial & Non – Commercial dimension of organisational structure.
  - c. Traditional & Modern dimension of organisational structure.
5. What are the major dimensions of organisational structure?
6. Describe the factors determining organisational structure.

\*\*\*

---

## Lesson - 24 : Organisational Change

---

### Objectives

*After reading this lesson, you should be able to:*

- ▶ Explain Steps In The Change Process;
- ▶ Know Why Change Is Resisted; And
- ▶ Understand Strategies Management Uses To Make The Change Effective;

### Lesson Outline

- ▶ Pressures for change
- ▶ Sources of resistance to change
- ▶ Change process
- ▶ Management of change
- ▶ Review Questions

Changes are taking place all around without exception. It is but natural that everything changes over time. What remains constant is change itself? Therefore, it's the responsibility of the manager to appreciate the change, assess its impact on the organization and prepare to adopt it, if necessary. Depending on the magnitude of change, it may impact an individual, a group, structure, process and subsystems. By scanning the environment and deciphering how changes in the environment are likely to widen the gap between desired and actual state of affairs of organization such as productivity, customer and employer satisfactions ,the degree and impact of change could be gauged. Manager can be a change agent by introducing planned changes in the organization.

### Meaning and Nature of Change

The term change in the organization context refers to any alteration that occurs in the work environment. Planned changes mean those changes which are effected in a planned manner after assessing the need for change and working out the details as to when and how they will be carried out. A planned change is also called *proactive change*. In contrast, reactive change is the one which takes place in random fashion as a crisis situation develops. For proactive or planned change to be initiated, manager shall be sensitive to the environmental changes affecting the organization so that organizational crisis situations can be averted.

Planned change or pro active change is purposeful or goal directed. There are two widely recognized goals of the planned change. *One*, it sets to improve the organizational ability to cope with, or adapt to change environment. *Second*, it seeks to change employee knowledge, attitude and behavior. Change in any part of the organization tends to effect the whole organization. Change is a human as well as a technical problem. Whenever there is a change, social equilibrium in the organization is affected. When change occurs in the organization, it requires employees to make new adjustments as the organization seeks new equilibrium.

### **Pressures for Change**

The need for change exists when the manager finds that the goals are not being achieved. Thus, tension points in the organization are identified when the gap between the desired and the actual results is noticed. Such gaps could occur due to certain changes. In other words, these changes are precursors for organizational change, which are explained in the following pages.

***Labor market Environment:*** one important aspect of labour market environment is the changing nature of the work force in terms of aspirations, outlook and various demographic variants. The work force composition is fast changing with increasing proportion of the woman, minorities, physically challenged. For instance, in India the work force diversity, of late is something unseen before. The present generation of work force wants quantification and seeks external reinforcement. Human resource management policies will have to change to attract, maintain a diverse work force. Increasing participation of woman means dual-career couples. So organizations have to change their transfer and promotional policies as well as provide child and elder care facilities. On the whole, there has been an increase in the formal education levels of work force. Modern businesses, therefore, have to redraw their human resources development plans and methods. Training programs need to be fine tuned aiming at upgradation of skills.

***Technological developments:*** Changes in technology bring in their wake corresponding changes in the nature of the work. Computers, telecommunication systems, robotics, and flexible manufacturing systems, flexi time mode are some of the 21st century changes that have brought unimaginable changes at work place with respect to the time, comfort required for the execution of tasks. With changing technologies employees skills become obsolete. Hence, heavy investments become imperative. Modern control techniques substitute direct supervision which leads to wider spans and there by flat organizations. Information technology makes organizations more responsive to consumer demands. Narrow specialization in jobs gives way to work teams whose members perform multiple tasks and actively participates in group decisions.



**Economic conditions:** this is an age of discontinuity. To mention a few, oil shocks, accelerated inflation and interest rates, the stock market crashes, currency devaluation, etc., hit some industries and firms much harder than others. Globalization of markets is yet another significant change. The problem with these shocks is that it is impossible to predict what the future shocks will be and from where they come from.

**Social Trends:** High enrolment ratios are noticed in higher education. Higher education as a sector provides a mass market product. There is a changed composition of student community. Considerable proportion of woman students, part time students, outnumbering regular students has become the order of the day. Universities and colleges which fail to respond to these changes may find the going tough.

**Work place diversity:** Emergence of global markets, mobility of factors of production across the globe, integration of economic systems imposes certain demands on employees who have to interact with people in other countries and work with persons brought up in different cultures. Business organizations, therefore, have to prepare the work force which could perform and feel at home regardless of the place of work and the composition of work teams.

**Competition:** Competition is intensifying by the day in every product category. Businesses also in line with the changed realities and compulsions need to address themselves to the global context. Competitors may come from anywhere in the world, at times even from quite unexpected quarters. Heightened competition also means organizations need to defend themselves against traditional competitors and small entrepreneurial firms with innovative changes. Therefore, in order to meet competition, successful organizations in future rely on short production runs, short product cycles and a stream of innovative products. These will demand flexible work processes and schedules that can adapt to rapidly and even radically changing conditions.

### **Sources of Resistance to Change**

Any change is complicated by the fact that it does not produce a direct adjustment. Instead, it operates through employees attitudes to produce a response that is conditioned by feelings towards change. The following chart known as Roethlisberger's x-chart explains how attitudes affect the response to change.

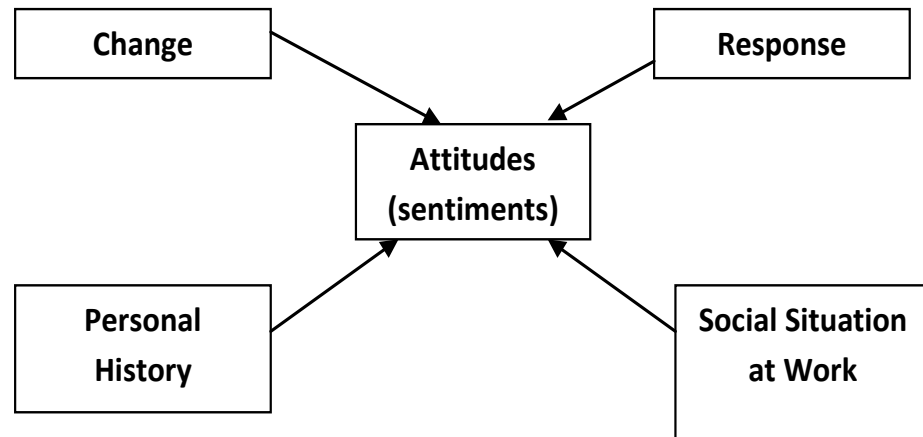

**Figure 24.1.: Roethlisberger's x-chart**

From the above chart, it is obvious that how people feel about change ultimately determines the response to change. People as individuals interpret change with attitudes in the back ground. The response is expressed through the group behavior. All changes have some costs, economic, psychological and social costs. Because of these costs associated with change, initiatives for change require analysis to determine their usefulness. Hence, cost benefit analysis of change is required. The goal of any organization is to maximize the benefits. Organizational members are affected in different ways by a change. Some may benefit while others suffer losses. This is the reason why employees tend to resist work change because of the associated costs. The following are reasons for, and consequences of, resistance to change.

### **Three Types of Resistance to Change**

They are Logical, psychological and sociological

**Logical:** arises from the time and effort needed to adjust to change. It is also due to new job duties to be learnt. These are short run costs to be paid by employee, though in the long term they are benefited by change.

**Psychological:** may arise due to attitudes and feelings of individuals about change. They fear the uncertainty, mistrust the management and feel insecurity. Therefore prefer status quo.

**Sociological:** political conditions, opposing union values, narrow outlook, vested interests, and desire to retain existing friendship are some of the reasons for resisting change.

Alternatively, resistance to change can also be studied under individual resistance and organizational resistance.

**Individual resistance:** The source of resistance resides in basic human characteristics, which are presented hereunder in a summary form:

**Habit:** To cope with life complexity, human beings rely on habits or programmed responses. Confronted with a change, the tendency to respond in habitual ways is a source of resistance.

**Security:** persons with high need for security resist change. In technologically intensive society, people perceive threats to the jobs and economic security. Hence, they resist change.

**Economic factor:** one's concern that change will lower one's income is another source of resistance. When pay is tied to performance, people fear that they may lose their income by not being successful in performing their new job, more so when they need to apply new set of skills.

**Need for security blanket (Fear of the Unknown):** apart from economic and job security, people prefer predictability and structured patterns in their lives. The need for this security blanket also makes them apprehensive about the change that characterizes ambiguity and uncertainty. Therefore, the preference for known for the unknown is obvious.

**Selective information processing:** people see the world through their perceptions. They see and try to understand and accept information that is palatable to them. They ignore information that challenges the world they wish to operate in.

**Apprehension about understanding of status and authority:** change in technology of work methods "undermining authority and status" is a source of resistance to change.

**Resistance is stemming from retooling and retraining:** knowing that one has to learn new things is a source of resistance to change as any learning involves unlearning.

**Resistance due to non-involvement in the change process:** when changes are incorporated with little input from those who are affected by them, resistance to change is expected.

**Resistance due to sunk costs:** older employees seem to resist change more than younger ones. They have more psychological investment in older traditions. This is otherwise known as 'sunk cost' of energy and time.

**Organizational Resistance:** organizations by their very nature are conservative. They also become blindfolded and resist change. Six sources of organizational resistance to change are explained in what follows:

**Structural inertia:** organizations have built in mechanisms to produce stability such as selection process which chooses certain persons, training and socialization process reinforcing specific role requirements and skills and formalization of jobs for employees to follow. When change confronts organizations, their structural inertia acts as a counter force to organizational stability.

**Limited focus of change:** limited changes in sub-systems of the organization are likely to be opposed.

**Group inertia:** here group norms act as constraints for change. Threat to Expertise: organizational changes may be threat to the expertise of specialized groups. For example, decentralized end user computer was a threat to the specialized skills held by the centralized information systems departments.

**Threat to established power relationship:** any redistribution of authority for decision-making can be threat to established power relationships. For example, participative management is a kind of change seen as a threat to the authority of middle level managers.

**Threat to established resource allocation:** change is seen as a threat by those groups controlling sizeable resources of the organization.

**Consequences of Resistance to change:** consequences are both positive and negative

#### ***Positive consequences***

- Resistance may force management to reexamine change proposals so that they are appropriate.
- Resistance also pinpoints specific problem areas so that management can take corrective action before problems become serious.
- It also encourages management to communicate change which in the long run ensures acceptance of change.

#### ***Negative consequences***

Organizations failing to overcome resistance to change have to pay a price. Change of greater magnitude introduced without gaining employee acceptance may lead to overt consequence such as employee unrest leading to strike, gherao, sabotage, etc. Implicit reactions to change may lead to alienation from the job i.e., tardiness, absenteeism and turnover.

### **Change Process**

Since management initiates more changes in the organization, its primary responsibility is to implement change successfully. Management is

called a change agent because its role is to initiate change and make it work. Many changes also originate in external environment. Rate of change varies according to nature of environment. Stable environment means less change. Dynamic environment means more change.

Kurt Lewin, the father of change process, stated three stages in initiating and establishing any change unfreezing, changing and refreezing.

**Unfreezing:** It is a process of preparation for change through discontinuation of the old practice, attitudes, or behaviours. This is the initial stage where change agents sense need for something new and are impatient with status quo. Thus the system is to be unfrozen from its complacency.

**Changing (or moving):** In this stage planned change is initiated and carried out. Change could relate to any aspect of the organization. With the participation of members affected by change, changes have to be carefully implemented.

**Refreezing:** This phase ensures that the planned change introduced is working satisfactorily and there is a reasonable guarantee that the change will indeed fill the gap and bring the system to the desired state of equilibrium. If the refreezing phase is neglected, the change will not bring desired result and may be even total disaster.

## **Management of Change**

Organization at any given time is a dynamic balance of forces supporting and restraining any change. The organization system is in a state of relative equilibrium. The current practice continues until the change is introduced. Change is introduced with in a group by increasing the supporting forces for it and/or reducing the restraining forces.

**Strategies to build support to change:** Chin and Benne describe three strategies managers commonly use in introducing organizational change:

**Empirical – Rational Strategy:** Managers acting as change agents must subscribe to the belief that people are rational beings and if they understand that the proposed changes will benefit them, they tend to accept change.

**Normative – Reeducative Strategy:** In this strategy, the belief is that people are guided by the socio-cultural norms they subscribe to. Hence, the change agent and those who will be influenced by the change should participatively and collaboratively plan and implement the necessary change.

**Power – Coercive strategies:** are used by the change agents assuming that people with less power will accept change brought by people with more power in the system.

Resistance could be to change itself, to the strategy to implement change, to the change agent or to the timing of change. Since there is no one best way of dealing with resistance to change in all situations, the following general approaches are used in handling resistance.

(i) **Education and Communication:** where there is a dearth of information or when inaccurate information is floating around, the change agent can discuss the change contemplated or apprise the employees about the logic of change and its attendant benefits. Once the employees are educated and enlightened about the positive aspects of change, they accept change.

(ii) **Participation:** Participation encourages commitment rather than mere compliance with change. Greater the participation, lesser the resistance to change. This is illustrated in the following figure.

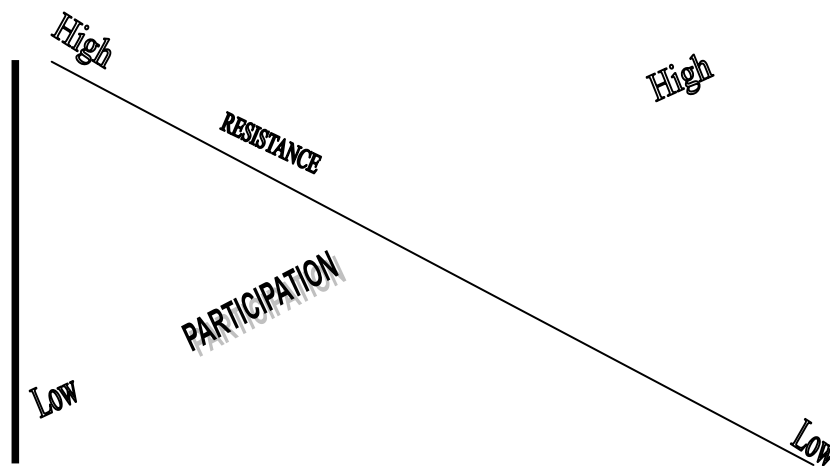

Figure 24.2: Participation Curve

(iii) **Facilitation and Support:** because of fear of inability to readjust, people resist change. To overcome it, the support in terms of empathic listening and training help the individuals to deal more effectively with their adjustment problems.

(iv) **Negotiation and Agreements:** individuals and groups may resist change because they will be at a disadvantage when the proposed change is introduced. In such situations incentives or special benefits are offered to those resisting change so that they cannot block change.

(v) **Coercion:** Implicit and explicit coercion can be used when changes have to be speedily enforced or when changes are of temporary nature.

**(vi) Manipulation and co-optation:** Covert attempts (manipulation) such as selective sharing of information and consciously structuring certain type of events would win the support for change. Giving key role to those revisiting change in the change decision is known as cooptation.

**(vii) Leadership for Change:** effective leadership reinforces a climate of psychological support to change. Change is more likely to be successful if the leader introducing change has high expectations of success.

**(viii) Use of Group Forces:** The idea is to help the group join with management to encourage and support desired change.

**(ix) Working with Unions:** Union-management differences lead to conflict over change. Most unions support change that is carefully planned to protect member interests.

**(x) Working with the Total System:** resistance to change can be reduced by helping employees to recognize the need for each change, to recognize the need for each change, to participate in it, and to gain from it.

## Review Questions

1. "Change is basically positive." Discuss the pros and cons of this statement.
2. Resistance to change is often viewed negatively. Discuss some possible benefits of resistance to change in an organisation.
3. Considering that change even further, was there an organisational learning curve for it? Discuss its length shape and some of the problems that developed.
4. Continuing the analysis of this change, how did management alter the restraining and supporting forces for it? Discuss.
5. Think of an organisation change that you have experienced. Was there resistance of the change? Discuss. What could have done to prevent or diminish it?

\*\*\*





---

## Lesson - 25 : Organisational Development (OD)

---

### Objectives

*After reading this lesson, you should be able to:*

- ▶ Define What Organizational Development Is And Its Characteristics;
- ▶ Spell Out The Objectives, Benefits And Cost Of The Od;
- ▶ Explain Approaches To Od; And
- ▶ Understand Od Programs.

### Lesson Outline

- ▶ Definition Of Od And Its Characteristics
- ▶ Process, Benefits And Limitations Of Od
- ▶ Approaches Of Od
- ▶ Od Programs And Techniques
- ▶ Review Questions

As a logical extension of the previous lesson which focused on organizational change, this lesson deals with OD as an applied, macro-level approach to planned change and development of organizations. Definitions of OD, its characteristics, benefits and costs, OD approaches and techniques are discussed in that order.

### A few Definitions on OD:

Keith Davis defines OD *“as an integrated strategy that uses group process to focus on the whole culture of organization in order to bring about planned change. It seeks to change beliefs, attitudes, values, structures, and practices so that the organization can better adapt to technology and live the fast pace of change”*.

According to Fred Luthans, OD represents *“an applied, macro-level approach to planned change and development of complex organizations”*.

**Characteristics of OD:** OD characteristics are implied in its definitions. They differ substantially from those of a typical training program which are summarized in the following lines.

**Focus on the whole organization:** in OD attempts are made to develop the whole organization so that it can be responding to changes effectively. In contrast, traditional training programs tend to focus quite narrowly on specific jobs or small work groups.

**Systems organization:** OD is concerned with structure, process as well as attitudes. It lays emphasis on how parts relate, not on the parts themselves.

**Problem solving:** OD seeks to solve problems rather than to discuss theoretically. This focus on real ongoing problems, not artificial ones, is called action research. This characteristic of OD is so important that OD is sometimes defined as “organizational improvement through action research.”

**Experiential learning:** OD offers experiential learning which means participants learn by experiencing in the training environment the kind of human problems they actually face on the job.

**Contingency orientation:** OD is said to be situational or contingency-oriented. Unlike traditional training approaches which emphasize one best way to solve the problems, OD is flexible and pragmatic, adapting actions to fit particular needs.

**Team building:** OD’s general role is to build better team work throughout the organization. OD attempts to integrate four elements- people, structure, technology and environment.

**Feed back:** OD relies on data feedback to participants who made decisions using it

### **Process, Benefits and Costs of OD**

**OD process:** A typical complete OD program includes the following steps.

**Initial diagnosis:** OD program is decided after the consultant meets the top management. By means of interviews with various persons the consultant seeks necessary inputs. Data collections and surveys may be made to know the organizational climate and organizational behavioral problems. By meeting the groups away from work, the consultant develops information, from issues pertaining to conditions that contribute most to job effectiveness, conditions that interfere with job effectiveness and the changes in the way the organization operates at present.

**Action planning and problem solving:** groups use the data to develop specific recommendations for change. Their discussion focuses on problems in the organization. Plans made are specific pinpointing who is responsible and by what time the action shall have been completed.

**Team building:** during the group meetings the consultant encourages groups to examine how they work as a team. He also helps them to see the value of open communication and trust as pre-requisites for improved group functioning.

**Intergroup Development:** first small group teams are developed followed by development of large groups comprises several teams.

**Evaluation and follow-up:** the consultant helps the organization evaluate results of OD efforts and develops additional programs in areas where additional results are needed.

If the organization expects to gain the full benefits of OD, all the steps in the process are to be applied.

**Benefits of OD:** primary advantage of OD as a useful method of organizational intervention is that it tries to deal with change in the whole organization or major unit of it. Hence, it ensures widely dispersed improvement. Other benefits include high motivation, productivity, quality of work, job satisfaction and conflict resolution. OD also reduces negative factors such as absenteeism and labour turnover.

**Limitations (or problems) of OD:** It is time consuming and expensive. Since benefits of OD require long pay-off periods, organizations may not prefer waiting that long. There are problems of invasion of privacy and psychological harm in some of the OD techniques. Criticism against OD is that participants in OD programs are coerced to group attitudes and thereby to conformity. Yet another criticism is that OD emphasizes too much on behavioral processes rather than on job performance. Group processes are given priority over needs of the organization.

## **Approaches to OD**

OD development can be traced back to the application of behavioral science and social psychology and to subsequent efforts to apply laboratory training survey-feedback insights into social system. Kurt Lewin was instrumental in both the approaches namely laboratory training and survey feedback.

Two important ways of theorizing for OD according to Burke and Litwin, are organizational functioning and organizational change. To them both transformational and transactional factors affect motivation which in turn affects performance. Transformational changes occurring in response to external environment directly affects organizational mission and strategy leadership and culture. In turn, transactional factors such as structure, system, management practices and climate are affected.

A theoretical model for planned organization change and development is presented below:

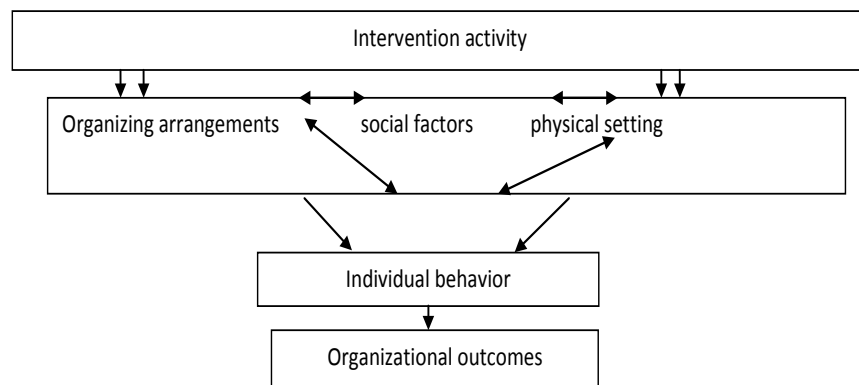

**Figure 25.1: Theoretical model for OD**

This model is predictive. The three implications of this model are:

1. As a starting point change agents should focus on systematic change in organizational work setting and on individual behavior change as a key mediator associated with organizational outcome.
2. The results of technological intervention in organizational setting indicates negative individual behavior change need not necessarily lead to negative organizational outcome change.
3. This theory provides a better framework of choosing interventions than the case where intervention is decided by change agent's preferences, values and styles.

**Potential areas of OD Intervention:** Areas where OD Interventions help include people side of the organizations, the technical and job related aspects and structural aspects.

**People side of the organization:** OD interventions under people side encompass a) *interpersonal or individual level* -personnel counseling and career planning; b) *dyadic (two-person) level* solving problems in interpersonal communication and in superior sub-ordinate relationship; c) *group level*- helping people to get along with each other and clarifying perceived incongruencies in goals; and d) *family level* –helping couples to get adjusted to new transfers and relocations, and conducting work-shops for dual career family members to better manage the work-family interfaces. OD techniques used to address “people concerns” are *sensitivity training, transactional analysis, process consultation, third-party peacemaking, team building, individual counseling, life and career planning, role clarification, and workshops.*

**Technical and job related aspects:** Areas of OD intervention include work flow inter-dependencies, job evaluation and job redesigning and the like. Some of the techniques that come handy are socio-technical system analysis, flexible production, job evaluation techniques and role analysis techniques (JET and RAT).

**Structural aspects:** They include interventions to change the physical settings, work group structuring as autonomous (self-managed) work groups, changes in the extent or formalization and control etc. Other techniques used to increase the effectiveness of the organization are the management grid and Likert's system in techniques.

## **OD Programmes and Techniques**

OD field is largely technique driven. The most established and popular techniques are presented below. A study of these techniques reveals a lot about what OD is.

### **Laboratory training methods:**

**(a) Role playing:** it is spontaneous acting of a real situation involving two or more people under class room conditions. Dialogue is spontaneously developed by the trainees assigned to role playing. Role playing is a substitute for experience. But it is more than that because it permits techniques of observation and discussion unlike experience. In role playing, trainees can broaden their experience by trying different approaches while in real situation they have only one chance.

It has certain weakness. It is time-consuming and expensive. Experienced trainers are required, since it can easily turn sour without effective direction. Some trainees resent it as being a childish approach to serious problems. Some others are hesitant to take part in role playing. Yet some others focus more on acting than in problem solving.

**(b) Gaming:** it is not extensively used. It differs from role playing in the sense that it focuses more on administrative problems while role playing tends to emphasis on feelings and tone between people. It is a group exercise in sequential decisions under simulated organizational conditions. Participants work in small groups, each group in competition with others. Groups make decisions in a created system model at least partly unknown to them. Decisions are processed through a computer according to the model, thus providing feedback for subsequent decisions. Usually time is compressed. For example quarter year operations may be covered in a single morning or afternoon session. The fact that time can be compressed, makes it possible to gain much experience with different approaches in a short period of time. The learning process can be hastened through feedback and discussion with a trainee after each decision unit.

(c) **Encounter groups:** they involve unstructured group interaction under a stressful situation requiring people to be sensitive to one another's feelings in order to develop reasonable group activity. Encounter groups are not role playing, because participants act their own true roles. But their environment is so artificial that their ordinary social patterns prove to be no more workable. Encounter groups seek to improve understanding of self, others, group processes, culture and general behavioral skills. The emphasis in this kind of training is on group processes, that is how group works and on the learning from group experience.

**Transactional analysis:** first introduced by Eric Berne, it analyses the nature of people's verbal interactions with each other. The basic principle of TA is that each one of us operates from three ego states and there are compatible and incompatible messages we send to each other.

#### **The three Ego stages:**

*The parent state:* it reflects our feelings of superiority, authority, being judgmental, etc.

*The child state:* it reflects childish tendencies such as dependence, impulsive, rebellious, and the like. We operate from all three ego states from different times. But we resort to one mode of interaction.

**Complementary transactions:** they come from compatible states where expected responses naturally occur.

**Crossed transactions:** they occur when the message from one ego state is responded to by a message from an incompatible ego state in another person.

**Ulterior transactions:** they take place when the two parties say things to each other which circumvent the main issue.

**Process Consultation:** From the organizational effectiveness point of view, it is important for the manager to understand the processes by which things get done. He to perceive, understand and act upon process events with which he must deal. PC is more task directed than sensitivity training. The essence of PC is the skilled consultant's work with the managers, other individuals, groups in the system to develop their process skills i.e., diagnose and resolve process-related problems.

**Survey Feedback:** it is a tool for assessing attitudes held by organizational member perceptions, identifying discrepancies among member perceptions and solving these differences. Attitude surveys of individuals and groups at all levels in the organization serve as data points to trace ends. Three significant

steps are involved in the system. *First*, persons holding primary positions in the organization plan what data need to be collected. *Second*, data are analyzed and feed back is given to the top management, and to the teams down the hierarchy. *Third*, each superior call for a meeting in which data are fed to the subordinates. The group members are asked to interpret data, suggest constructive changes necessary and tell how changes could be brought about.

Survey feedback is a good diagnostic tool used for several types of interventions. It is an effective intervention strategy since people realize that they are working with data that they themselves have provided. In other words they 'own' the data which spurs them on to initiate and implement the needed changes.

**Team Building:** Since people are often asked to work in groups, considerable attention has been focused in OD on team building. It aims at improving intra-and inter-group effectiveness. The activities considered in team building typically include goal setting, development of interpersonal relations among group members, role analysis to analyze member's role and responsibilities and team process analysis. When combined with survey feedback, team building is more effective.

**Organisational Mirroring:** it is a technique to both assess and improve organizational effectiveness by obtaining feedback from several other groups outside of the organization. Key representatives from the various outside organizations are invited to participate to mirror to the host organization on how it is perceived, what it can do to improve its effectiveness, and the plan of action to rectify the issues. The consultant interviews the people attending the meeting before the meeting is scheduled to assess the magnitude of issues and facilitate the problem solving process. Sub-groups of both host organization and invited organizations work together during the meetings to identify the problems and changes needed. The total group meeting subsequently identifies critical issues and recommends needed changes.

## Review Questions

1. The field of OD has been based on humanistic values. Discuss how its skills and intervention methods would be different if those values were not important.
2. Create a list of the kinds of organisational behaviour skills that would be useful to an OD consultant.
3. How role playing, simulation and behaviour modeling do differs as training methods? Do they have similarities also?
4. Examine in the OD assumptions. Which of these do you agree or disagree most strongly with? Explain your feelings.

5. Discuss the strengths and weaknesses of encounter groups?
6. What are the objectives of OD?
7. What are the benefits and limitations of OD?



## Case Study

### Implementing New Ideas

Industrial Hydraulics Ltd., is a public sector firm. The Assembly and test shops of the company are headed by Mr. Murthy, shop superintendent, who has one assistant superintendent Mr. Singh under him for both the shops. The two shift supervisors in test shop. Mr. Verghese and Mr. Mehta report directly to Singh. Murthy reports to factory manager and is an engineering graduate with about 15 years of service in the company. Singh, the Assistant Superintendent (27) has above five years of service in the company which he joined as a management trainee (tech.). He is popular amongst the workers and has a reputation for impartially and fair dealing on the shop floor. Mehta, the test shop supervisor (40) is an old timer in the company and is known to most of the old employees including senior officers. He has risen from the ranks and possesses ITI certificate. He is very well known to Murthy, under whom he served for a long time as a technician and later as asst. Supervisor. Verghese, the other supervisor in test shop is a young person, around 25, with a diploma in mechanical engineering and about 3 years of service in the company. He is shy, reserved and generally unknown outside his department.

The test shop is the bottleneck area of the department where a large accumulation of units, awaiting testing generally exists. The product mix consists of about 30% of components with a short test cycle time, 45% of components with medium cycle time and 25% of components with a long cycle time. The components with high and medium cycle time have generally complex test schedules and considerable effort if required to rig up test circuits.

The production targets are given on a monthly basis and weekly output is monitored by the factory manager. No realistic assessment of assembly and test timings exist. For the past 3 months, the test shop output has been very erratic while there is surplus production of short and medium cycle components which are not immediately required in the quantities produced; there is a large back log of urgently wanted long cycle time components.

One fine morning, Murthy was summoned by the factory manager and given 10 days time to rectify the situation. He was given to understand in unequivocal terms the failure to correct the situation shall be entertained by the management. Murthy in turn, immediately asked for Singh and gave him one week to clear the back log in test shop. Singh had studied the situation for quite some time in the test shop and had tried to analyse the reasons for the erratic output. He was of the opinion that Mehta the "B" shifts supervisor was mainly responsible for the situation. He had a tendency to pick up only short cycle time components for test and never made any attempt to take long cycle time components. He was, in the opinion of Singh, deliberately avoiding difficult and urgently required components to show higher output from his shift.

Singh presented his analysis to Murthy who showed his complete disagreement with Singh's analysis. He found nothing wrong of "B" shift and complimented Mehta for giving high output. He strongly advised Singh to concentrate his attention of shift "A" and leave Mehta alone. Singh knew that his reasoning at this stage, either with Murthy or Mehta will not out much ice. He quietly decided to experiment with a new idea which he called the concept of 'point performance rating'. The idea centered around giving weightage to each item in terms of number of points depending upon the degree of complexity in setting to test circuits and associated cycle time. He also intended to use this date as a sort of merit rating for individual operators.

Singh presented his scheme to the two shift supervisors. Verghese was quite receptive and as expected, there was a lot of resistance from Mehta. After a lot of discussion, Mehta offered to try the scheme for a limited period but he expressed his reservations about the success of the scheme. He wanted to approach Murthy who had proceeded on temporary duty to company had office for some urgent work. Singh overcame the resistance from workers primarily because of his reputation for fair dealing and straight forwardness. However, he informally made it known to some of the workers that constant higher accumulation or points by individuals shall indicate the efficiency and skill of the individual and may carry weightage at the time of department promotions. The scheme was informally introduced and was quite effective. Meanwhile, Murthy returned from his temporary duty and was quite impressed with Singh's performance. He gave his blessings for the continuation of the scheme. Shortly afterwards, some departmental promotion were announced. As it happened, quite a few of the good workers from test shop were ignored for promotion. Majority of workers promoted were from assembly shops. The workers overlooked from test shops were those with a consistent high accumulation of points. The workers reacted and boycotted the Point Rating Scheme stating that if merit plays no part in deciding promotion, why should there be a merit rating scheme. Singh tried to take up the issue of promotions with Murthy but was quietly told that there is nothing wrong with promotions as senior workers have been promoted. He was advised not to get worked up about the issue. Meanwhile, some of the disgruntled workers approached the union and represented objected to the scheme and demanded its immediate withdrawal stating that no such scheme can be introduced without the union's concurrence and the whole basis of allotting weightage is untenable. The factory manager, when approached by union office bearers expressed his ignorance about the existence of any scheme of this kind and demanded an immediate explanation from Murthy. Murthy in turn put the entire blame of Singh.

### **Questions**

1. Identifying the problem faced by the organisation as against the symptoms seems easily in the case.
2. Generating the solution/ alternate solutions to the solution perceived by Mr.Singh.

3. Implementing the solution, taking care of pitfalls, a young executive should avoid at different phases of implementation.

\*\*\*



## UNIT – V

---

### Lesson - 26 : MANAGING DIVERSITY

---

#### Objectives

*After reading this lesson, you should be able to:*

- ▶ Appreciate Diversity At The Work Place;
- ▶ Understand The Reasons For Work Place Diversity; And
- ▶ Equip Yourself With The Strategies To Manage Diversity.

#### Lesson Outline

- ▶ Meaning Of Diversity
- ▶ Reasons For Diversity
- ▶ Managing Diversity In Organisations
- ▶ Review Questions

All around the world managing workforce diversity has taken a central stage among the contemporary human resources management issues confronting the managements regardless of the location of business. The integration of the global economy contributed by the development in transport and telecommunication facilities apart from the economic compulsions has changed the composition of workforce in many organisations. In a country like India the issue has acquired greater significance given the diversity with respect to culture, orientation and outlook of the people of different regions of the country. There is no exaggeration that one would find himself entering totally a different cultural zone for every 200 – 300 kms. of travel in any direction in India. The same is reflected now in the business organisations also due to increased levels of literacy, job opportunities and mobility of the people. Therefore it is not uncommon to find in any work group, individuals with different cultural background and orientation work together for common goals. The emerging situation in many workplaces with respect to diversity poses a challenge to the modern manager. It is therefore imperative to clearly understand the complexities of diverse workforce and to manage the same.

#### Meaning of Diversity

Diversity exists in a group or organisation when its members differ from one another along one or more important dimensions. It may be noted that diversity is not an absolute phenomenon. It has to be viewed as a continuum. For instance, if everyone in a group is exactly like everyone else, there is no diversity. Similarly, if everyone in the group is completely different from the other, it implies total diversity. However, in reality these are

hypothetical situations. Most of the work groups are characterized by a level of diversity somewhere between these extremes. That being the case, diversity at workplace should be seen in terms of degree or level of diversity along various dimensions.

The various dimensions of diversity include gender, age, ethnic origin, colour, among others. For instance, a group comprising five male young men from Tamil Nadu in a workplace has relatively little diversity. If one member is replaced by a young female from Tamil Nadu, the group becomes a bit more diverse. If another member is replaced by a young man from Punjab diversity increases a bit more. Further, if a third member is replaced by a young man from Assam, the group becomes even more diverse. That is how, diversity in a work place has to be seen and understood.

### **Reasons for Diversity**

Modern organisations are becoming increasingly diverse along many characteristics dimensions. Though several factors contribute for the increasing diversity, let us confine our discussion to the following four important dimensions.

#### ***i. Changing Demographics***

Demographic changes at the work place relate to the age, gender, literacy, etc. With the spread of higher education and as many segments of the society which are hitherto outside the reach of higher education, there is also a perceptible shift of people to professional education like Information Technology, Biotechnology, Material sciences, Management and so on. As a result, mobility in the labour market by virtue of opening up of new sectors across the world has become the order of the day. Similarly, the proportion of women employees in the workforce is also increasing at a faster rate. Thanks to the spurt of information technology jobs, a large number of young people straight out of college are into making a career at a very early age. Further, due to the spread of non-formal and distance mode of education, even the middle aged people are acquiring necessary academic credentials and joining the workforce. All these demographic changes unheard of 10 – 15 years ago however are largely responsible for increased diversity at work place, of late.

#### ***ii. To gain Competitive Advantage***

Unlike in the olden days, modern organizations are going all-out in search of talent. They are casting the net very wide. They are looking beyond the traditional sources, perhaps to infuse new blood in the organisations. In order to groom and encourage diverse thinking and diverse perspectives, which constitute an essential prerequisite for organizational creativity and innovation, many a business, deliberately planning for diversity in the work force. In the present day context, when all the other inputs excepting the

human resource are standardized and accessible to every firm, obviously, it's quality of the human resource that makes a difference. Modern organizations are structured and managed to encourage diversity as divergent thinking/perspectives of people in the work group setting facilitate and foster creative ideas/solutions that provide the basic ingredients to new product development and exploration of new markets.

### *iii. To meet the legal and regulatory requirements*

In order to meet the constitutional obligations and for balanced development of people of various denominations and regions, the government makes it obligatory on the part of businesses to address some of the issue related to the employment of people from minorities, weaker sections, physically challenged, backward regions, etc. Therefore, as a part of social responsibility, modern businesses are expected to reach out to these sections which in turn contribute for the diversity.

### *iv. Globalisation of Business*

Modern organisations are borderless. The size and scope of the operations have enormously increased. Movement of capital, technologies, labour and strategic resources across the nations are taking place in an unprecedented scale. Takeovers, mergers and strategic alliances of the companies located in different parts of the world have become every day's corporate buzz. As a result, business operations are spread over many markets and nations. As such the need for people familiar with the local culture to man the global operations has also increased. Organisations which open offices and facilities in other countries have to learn to deal with different customs, social norms and mores. Consequently, as employees move from one assignment to other across the global organisations and their outfits in different parts of the world, the work force becomes more and more diverse.

## **Managing Diversity in Organisations**

Since diversity in work place has become a rule rather than an expectation, managers have to understand the fast changing complexion of the workforce and learn to manage the diversity effectively. Management of diversity involves initiatives at two levels, viz., at the individuals and at organisational level.

### **Individual Strategies for Dealing with Diversity**

One important element of managing diversity in an organization consists of those things that individuals at their level can attend to such as: better understanding, empathy, tolerance, and willingness to communicate.

#### **Understanding**

Understanding the nature, meaning and complexity of diversity constitutes the core of the whole issue. Some managers take the basic concepts of equity and justice in employment opportunities to an unnecessary extreme. They know that, by law, they cannot discriminate against people on the basis of sex, race, and so forth. Thus in following this mandate they come to believe that they must treat everyone the same.

But this belief can cause problems when translated into workplace behaviours among people after they have been hired because people are not the same. Although people need to be treated fairly and equitably, managers must understand that differences among people do, in fact, exist. Thus any effort to treat everyone the same, without regard to their fundamental human differences will only lead to problems. Managers must understand that cultural factors cause people to behave in different ways and that these differences should be accepted.

### **Empathy**

Related to understanding the issues and problems from the other's perspective is empathy. People in an organization should try to understand the perspective of others. For example, suppose a woman joins a group that has traditionally comprised men. Each man may be a little self-conscious as how to act towards the new member and may be interested in making her feel comfortable and welcome. But they may be able to do this even more effectively by empathizing with how she may feel. For example, she may feel disappointed or elated about her new assignment; she may be experienced or inexperienced in working with male colleagues. By learning more about her feelings, the group members can further facilitate their ability to work together effectively.

### **Tolerance**

A third related individual approach to dealing with diversity is tolerance. Even though managers learn to understand diversity and try to empathise with others, the fact remains that they may still not accept or enjoy some aspect of others' behaviour. The intolerance for others increases where the economic and job opportunities are fewer. The scramble for opportunities is the cause for any conflicts among people.

### **Willing to Communicate**

A final individual approach to dealing with diversity is communication. Problems often get magnified over diversity issues because people are afraid or otherwise unwilling to openly discuss issues related to diversity. For example, a young employee has a habit of making jokes about the age of an elderly colleague. Perhaps the young colleague means no harm and is just engaging in what she sees as good-natured kidding. But the older employee may find



the jokes offensive. If the two do not communicate, the jokes will continue and the resentment will grow. Eventually, what started as a minor problem may erupt into a much bigger one!

For communication to work, it must be two way. If someone is offended by the behaviour of another person, he or she should explain to the offending individual how the behaviour is perceived and request that it be stopped. As long as such exchanges are friendly, low key, and nonthreatening, they will generally have a positive outcome. Of course, if the same message is presented in an overly combative manner or if a person continues to engage in offensive behaviour after having been asked to stop, problems will only escalate. At this point, third parties within the organization may have to intervene. And in fact, most organizations today have one or more systems in place to address questions and problems that arise as a result of diversity. We now turn our attention to various ways that organizations can indeed better manage diversity.

## **Organizational Approaches to Managing Diversity**

Whereas individuals are important in managing diversity, the organization itself must play a fundamental role. Through its various policies and practices, People in the organization come to understand what behaviours are and are not appropriate. Diversity training is an even more direct method for managing diversity. Therefore, the organization's culture is the ultimate context from which diversity must be addressed.

### **Organizational Policies**

The starting point in managing diversity is the policies that an organization adopts that directly or indirectly affects how people are treated. Obviously, for instance, the extent to which an organization embraces the premise of equity and justice in employment opportunities will to a large extent determine the potential diversity within an organization. But the organization that follows the law to the letter and practices only passive discrimination differs from the organization that actively seeks a diverse and varied workforce.

Another aspect of organizational policies that affects diversity is how the organization addresses and responds to problems that arise from diversity. For example, consider the example of a manager charged with sexual harassment. If the organization's policies put an excessive burden of proof on the individual being harassed and invoke only minor sanctions against the guilty party, it is sending a clear signal as to the importance of such matters. But the organization that has a balanced set of policies for addressing questions like sexual harassment sends its employees a message that diversity and individual rights and privileges are important.

## **Organizational Practices**

Organizations can also help manage diversity through a variety of ongoing practices and procedures. In general, the idea is that because diversity is characterized by differences among people, organizations can more effectively manage that diversity by following practices and procedures that are based on flexibility rather than rigidity.

Benefits/incentives packages, for example, can be structured to better accommodate individual situations. An employee who is part of a dual career couple and who has no children may require relatively flexitime arrangements compared to the couple with no kid. The convenience in scheduling vacations also differs in both the cases. Flexible working hours are therefore, a useful organizational practice to accommodate diversity. Differences in family arrangements, religious holidays, cultural events, and so forth may each warrant some sort of flexibility at the work place. Organization can also facilitate diversity by making sure that its important committees and executive teams are diverse.

## **Diversity Training**

Many organizations are finding that diversity training is an effective means for managing diversity and minimizing its associated conflicts. More specifically, *diversity training* is training that is specifically designed to enable members of an organization to function in a diverse workplace. This training can take a variety of forms. For example, many organizations find it useful to help people learn more about their similarities to and differences from others. Men and women can be taught to work together more effectively and can gain insights into how their own behaviours affect and are interpreted by others. In one organization, a diversity training programme helped male managers gain insights into how various remarks they make to one another could be interpreted by others as being sexist. In the same organization, female managers learned how to point out their discomfort with those remarks without appearing overly hostile.

## **Organizational Culture**

The ultimate test of an organization's commitment to managing diversity is its culture. Regardless of what managers say or put in writing, unless there is a basic and fundamental belief that diversity is valued, it cannot ever become truly an integral part of an organization. An organization that really wants to promote diversity must shape its culture so that it clearly underscores top management commitment to and support diversity in all its forms throughout the organization. With top management support, however, and reinforced with a clear and consistent set of organizational policies and practices, diversity can become a basic and fundamental part of an organization.

## **Review Questions**

1. Explain the concept of work place diversity with examples.
2. What factors contribute for diversity at the work place? Explain the emerging trends in the Indian corporate sector with regard to the diversity.
3. What initiatives do you propose to manage diversity in organisations? Present any anecdotes that you are familiar with either from your own organisation or any other that you have heard of.

\*\*\*



---

## Lesson – 27 : Japanese Management Practices

---

### Objectives

*After studying this lesson, you should be able to:*

- ▶ Understand The Important Elements Of Japanese Management;
- ▶ Distinguish The Japanese And American Management Practices; And
- ▶ Examine How Far Japanese Management Practices Could Be Implemented In The Indian Context.

### Lesson Outline

- ▶ Unique Features Of Japanese Management.
- ▶ Comparison Of Japanese And American Management Practices.
- ▶ Weaknesses Of Japanese Management.
- ▶ Review Questions.

It is anybody's knowledge that Japanese economy was reduced to scrambles during the Second World War. The war had a devastating effect in that the whole economy had to be rebuilt from scratches. Looking back, it is quite amazing to note how Japan as a nation could achieve such a tremendous development in all the sectors of the economy in the span of about 60 years. In a way, Japan amply demonstrated to the whole world what a nation could achieve given the commitment and determination of its people. As such, there is no wonder that captains of the industry, management thinkers and practitioners all over the world began to examine the factors that contributed to the Japanese success -often described as 'Japanese miracle'.

In the several studies conducted by the management thinkers, it was found that the secret lies in their management practices. They have developed a comprehensive system that combines structure and people in the way that when integrated with Japanese culture, generates a highly productive and efficient organisation.

### Unique Features of Japanese Management

The Japan management system has three levels of attention: *An overall focus, general strategies and specific techniques.*

## **Focus**

The essence of management in large Japanese organisations is its focus on human resources. Management considers its human resources, more than its financial or physical resources. The Japanese organisations go all out to develop the human resources. Much of the Japanese management revolves around a distinct approach to personal management. Such a focus on the human resources helped the Japanese industry to achieve so much inspite of the poor endowment of the natural resources.

## **Strategies**

The concern for human resources is manifested in three interrelated strategies. First, employees are offered long-term employment. This demonstrates the organisation's commitment to its people. Second, the organisation's philosophy concerning employee needs and the values of cooperation and teamwork are well articulated. Third, close attention is given to hiring new employees who fit well in the organisation and to ensuring that this fit is maintained and enhanced throughout the employee's work life.

### **i. Life time employment**

The U.S. view towards employees is that when times are bad, employees are laid off and fired. In Japan, except in the most severe economic circumstances, employees are assured of permanent employment. Usually new employees are hired fresh out of educational institutions. The organisations then train them, make promotions from their internal pool, and emphasises seniority in the allocation of rewards. Long-term employment leads to high employee morale. For the organisation, the benefits are : low employee turnover, low training costs, and high organisational cohesiveness.

### **ii. Organisational philosophy**

Each Japanese organisation has a specific philosophy that presents a clear picture of its objectives and values. It acts as a super ordinate goal- a shared and unifying goal with which all organisational members can identify, support and place above any one person's individual goals. A common theme among Japanese companies is a heavy emphasis on cooperation and teamwork. Members of the company are part of a family. The theme spirit and cooperation characteristic of a family are possible with the security provided by the strategy of permanent employment.

### **iii. Intensive socialisation**

Employees once hired undergo an initial training programme, the purpose of which is to familiarise the employee with the organisation. Over a period, the employee identifies himself with the company. He is socialised very intensively.

## **Techniques**

### **i. Job rotation and slow promotion**

In Japan, life-time employment means limited upward mobility. Movement is predominantly lateral through job rotation. Promotions are based on seniority.

### **ii. Complex appraisal system**

In addition to the output, employees are appraised on the basis of traits such as creativity, honesty, seriousness, maturity and cooperation with others. Employees' performance in the long run is given more importance, since evaluation is done not exactly on the basis of immediate performance. Employees are naturally motivated to demonstrate loyalty and commitment by their attitudes and actions.

### **iv. Emphasis on work groups**

The Japanese system gives far greater attention to organising tasks around groups than around individuals. Autonomous work teams are constituted. Tasks are assigned to such teams and the group members of the team then decide among themselves the best way for performing the tasks.

### **v. Open communication**

The Japanese system is inherently designed to foster open communication. Job rotation and emphasis on groups means that employees build an informal network that facilitates extensive face to face communication. The physical work setting is also designed to foster communication. People work in cubicles and in open space which facilitate interaction and open communication.

### **vi. Consensus decision- making**

In the Japanese model, the manager while taking decisions discusses them to those who may be affected by the decision. When all are familiar with the proposal, a formal request for a decision is made, and as a result of the previous informal preparations, it is easily ratified.

### **vii. Concern for the employee**

Managers spend a great deal of time talking to employees about everyday matters. They take keen interest in employees' needs and problems. In fact, the concern for employees is one of the parameters on which managers performance is appraised. Japanese companies offer a wide range of benefits to their employees. Beyond the usual incentives, a comprehensive offering of cultural, athletic, and recreational activities are very common. For instance, an annual calendar of office events might include several overnight trips, monthly Saturday afternoon recreation, and an average of

six office parties- all at the company's expense. In addition, welfare measures like subsidized family housing for married, dormitories for the unmarried, nurseries for pre-school children, scholarships for children, mortgage loans and the like speak a lot about the concern for employees.

William Ouchi, an American management thinker, had extensively studied Japanese organisations and gave a name to their management practices, called "*theory z*". He strongly advocated for the adaptation of Japanese practices for the American companies to improve productivity. It is appropriate here to understand how Japanese practices differ from American management practices.



## Comparison of Japanese & U.S. Management practices

Japanese management	U.S. management
<p><b>Planning</b>            Long term orientation            Collective decision making            Many people are involved in decision making            Decisions flow bottom up and back            Decision making takes a long time, but implementation is fast            People share decision power &amp; responsibility            Individual goal ambiguity.</p> <p><b>ORGANISING</b></p> <p>Collective responsibility and accountability            Ambiguity of decision responsibility</p> <p>Informal organisation structure            Organisation culture and philosophy are well known.            Identification with company</p> <p>Organisational change by internal change agent.</p> <p><b>STAFFING</b></p> <p>Hiring young people out of school.            Slow promotions through ranks.            Loyalty to the company</p> <p>Infrequent performance appraised for new employees            Appraisal of long-term performance</p>	<p>Short term orientation            Individual decision making            Few people are involved in decision making            Decisions are Initiated at the top and flow down            Decision-making is fast but implementation is slow            Decision making power vests in designated individuals            Individual goal clarity</p> <p>Individual responsibility            Clarity of decision responsibility</p> <p>Formal organisation structure            Common organisational culture is lacking            Identification with profession</p> <p>Change prompted by external change agent</p> <p>From institutions and companies            Rapid promotion desired and demanded            Loyalty to the profession            Performance appraisal is frequent            Appraisal of short-term performance</p>

Reward for long term performance	Reward for short-term performance
Small differences in pay increases	Substantial differences in pay
Reward for group performance Promotions based on multiple criteria	Reward for individual performance Based on individual performance
Training and development considered a long –term investment	Training and development is on a low key due to high employee turnover
Exposure to many functions	Narrow career path
Lifetime employment	Absence of job security
Leader as a social facilitator	Leader as a decision maker
Leader is part of the group	Leader as head of the group
Paternalistic style	Directive style
Common company values facilitate cooperation	Often divergent values Individualism often hinders cooperation
Avoidance of confrontation emphasis is on harmony	Face to face confrontation is common
Confluence of working and private life	Highly separated
Emphasis on oral communication	On written communication
<b>CONTROLLING</b>	
Self control and control by peers	Control by superiors
Focus is on group performance	Focus is on individual performance
The objective of control is to save face	Control aims at fixing the blame
Extensive use of quality circles.	Limited use.

## **The Inherent Weaknesses of Japanese Management**

- The system of the life time commitment and groupism encouraged employee dependence and suppressed individual creativity.
- The employment system discriminated against non-life time employees and prevented the formation of a free horizontal labour market.
- The seniority based system of rewards created a promotion grid lock for middle management and especially for the younger outstanding employee.
- By the mid -1980s the entire system of Japanese management faced three major challenges:
  - After the dramatic rise in the value of Yen, the problem of cost containment became much more difficult. How to reduce labour cost and restructure without resorting to massive layoffs had become a problem.
  - How to continue to motivate employees in a new environment in which the system of evaluation and rewards, as well as employee attitudes and expectations are fast changing;
  - How to redesign employment relationships in a way that would blend the advantages of the order system of dependence in the company with the necessity to promote employees self-reliance, initiative and creativity.

## **The Emergence of a New Paradigm**

- Companies rely on hiring freezes and on elimination of overtime.
- Extensive use of job rotation and employee reassignments.
- Wage, salary and bonus reductions are shared by all groups in the enterprise; directors, managers as well as workers.
- Erosion of seniority and promotions based on seniority.
- Companies are using various forms of early retirement incentives.
- Relative contributions of merit factors to pay raises
- As a result, performance appraisal systems and wage structures are undergoing changes.
- Company and work group loyalties are replaced by individualism.
- Life time employment is undergoing change.
- Hiring on the basis of skills for specific, narrowly defined job openings is growing.
- Mobility among Japanese managers and professionals is also increasing.
- Japanese employees' preference for security over risk and opportunity is also changing.
- Creation of multi-track employment system. Employees hired for life can enter the general track and can be moved horizontally (job rotation) as well as vertically (grade promotion).

The changes going on are not designed to destroy the old system, but to increase its flexibility. This is very much in keeping with the traditional Japanese approach to change, however fast and deep it is. Continuity with the uniquely Japanese "essence" must be maintained. The new Japanese emerging

paradigm will certainly be different. Yet like the modern Japanese home which usually retains a Japanese style room among western style rooms and furniture, the Japanese company will retain a core of Japanese practices.

### **Review Questions**

1. Discuss the salient features of the Japanese management practices.
2. Distinguish between Japanese and American management systems. Also comment on how Indian management compares with Japanese.
3. Critically examine the feasibility of Japanese management approaches for the management of Indian industry.

\*\*\*

---

## Lesson – 28 : Creativity And Innovation

---

### Objectives

*After reading this lesson, you should be able to:*

- ▶ Know The Process Of Creativity And Its Importance In Developing New Products;
- ▶ Understand The Role Of Innovation In The Modern Organizations; And
- ▶ Infuse Entrepreneurial Spirit In The Organization That You Are Working For.

### Lesson Outline

- ▶ Creativity And Innovation
- ▶ Process Of Creativity
- ▶ Organisational Creativity And Innovation
- ▶ The Climate For Organisational Creativity
- ▶ Entrepreneurship
- ▶ Entrepreneurship Vs Managership
- ▶ Review Questions

The growth and survival of the business in the dynamic environment as of today depends upon the development of new products. Organizations must be always in the lookout for new opportunities and exploiting them by creating new products and services. Therefore, it is needless to say that new product development holds the key for the survival of an organization. New products do not come about on their own. They are the result of the ingenuity of creativity people in the organization. As such, it is obvious that new product development is the function of organizational creativity. In other words, it depends upon how creative an organization is in respect of new ideas. It may be understood any organization can be as creative as its people. Having understood the importance of creativity in the organizational context, let us understand the meaning and process of creativity.

### Creativity

Creativity, in general, may be defined as an “escape from mental stuckness”. In the organizational context, it may be viewed as new insights which points to better ways of dealing with reality. It involves a departure from conventional thinking to non-conventional thinking. It entails establishment of a relationship between the hitherto unrelated things, ideas or concepts. A close examination of many products enables us to understand how apparently

unrelated things are related to produce a new product. The ubiquitous wet grinder found in many of the kitchens may be cited as a best example where a relationship is established between the electric motor and the conventional stone used in the Indian homes for grinding purposes since times immemorial. Similar is the case with the electric bulb and the lens that are combined to develop the overhead projector used in the classrooms. The same logic holds good for many products that we see around.

## **Creativity and Innovation**

Though, at times creativity and innovation are used interchangeably, it is appropriate to know that both are different. While creativity is the generation of a new idea, innovation is the translation of such an idea into a product, service or method of production. In Lawrence B. Mohr's Woods, creativity implies "*bringing something new into being while innovation implies bringing something new into use*". According to Rosabeth Kanter, "*Innovation is the generation, acceptance and implementation of new ideas, processes, products or services*".

Such a distinction is necessary because the skills required to generate new ideas (creativity) are not the same as those required to make the ideas take the shape of products or services. Since both creativity and innovation are two different functions, organizations need people good at both the functions. Further, creativity alone does not contribute for organizational effectiveness unless the creative ideas can in some way be used or implemented. A new idea, however good it is, must be capable of implementation and must actually be implemented for the organization to benefit from it.

## **The Creativity Process**

Creative people, in general, are few and far between in any society. Many products and services that we take for granted these days are the result of their creative thinking. It was J.P. Guilford, a noted psychologist who coined the phrases '*divergent*' and '*convergent*' to describe different thinking styles in the early 1950s. Accordingly, Convergent thinking is the sort of thinking most of us are trained to do. Divergent thinking is quite different from convergent thinking. It is intuitive thinking and is quite different from convergent thinking. It is intuitive thinking useful to deal with problems permitting several possible solutions where novel, unexpected answers emerge.

Physiologically, our brain has two distinct hemispheres: one on the left side, and the other on the right side. Psychologists have long back established that these two halves have totally different jobs. The function of the left side of the brain is linear thought process- the type of thinking involved when you solve a mathematical problem. The right side of the brain acts or behaves in a different way. Its functions are connected with imagery, and with intuition or 'gut-feel'.

There is an obvious parallel between convergence/divergence and the left brain/right brain model. In other words, convergent thinking takes place in the left brain while, divergent thinking in the right brain. Having understood the two spheres of the human brain, let us acquaint with the process of creativity:

**Idea generation:** The individual selects a problem to work on or more likely become aware that a problem or need exists. This is the starting point for the new product development indeed. This refers to the awareness about the 'gaps' in the market.

**Preparation:** The individual becomes obsessed with the idea/ problem, recalling and collecting information that seems relevant and dreaming up hypothesis without evaluating them. Openness to experience, tolerance for ambiguity and willingness and courage to redefine the existing concepts, beliefs are the important psychological attributes required at the stage.

**Incubation:** After assembling the available information, the individual relaxes and the subconscious mind becomes active. In this not much understood but crucial step, the individual often appears to be idle or day dreaming, but the subconscious is in fact trying to arrange the facts into a pattern. Psychological freedom and safety are important at this stage.

**Illumination:** This is something which we experience quite often. Often, when least expected – while eating, falling asleep or walking- the new integrative idea will flash into the individual's mind. Such insights must be recorded quickly, because the conscious mind may forget them in the course of other activities.

**Verification and Application:** The individual sets out to prove by logic or experiment that the idea can solve the problem and can be implemented. Tenacity may be required at this point. It is at this state the individual switches over to the logical, analytical or convergent thinking. The practical implications are examined what is known as feasibility assessment- both technical and economic for commercialization of the idea/concept. This is also known as assessing the scalability.

## **Organizational Creativity and Innovation**

Just as individuals differ in their ability to translate their creative talents into results, organizations also differ in their ability to translate the talents of their members into new products, processes or services. To make the organization creative, managers need to know the steps involved in the creativity process presented above and take appropriate initiatives to encourage the process.

## Climate for Organisational Creativity

Creativity is best nurtured in a permissive climate which encourages the exploration of new ideas and new ways of doing things. The following aspects, if practiced, would contribute to fostering creativity in organization.

**Accept change:** Organisation members must believe that change will benefit them and the organization. Some resistance to change is found in many organizations for fear of losing position, learning new skills, etc. Such a resistance to change has to be overcome by clarifying the need and urgency for change. The adage that routine drives out the non-routine has to be revisited and must be seen the other way.

**Encourage new ideas:** Managers in the organizations, from top to the down must make it clear in word and deed that they welcome new approaches. To encourage creativity, managers must listen to their subordinates ideas and suggestions/ways of doing things. They must have an open mind.

**Permit more interaction:** A permissive, creative climate can be fostered if individuals have the opportunity to interact with other members of the group and other groups in the organization. Such interaction encourages the exchange of useful information, the free flow of ideas, and fresh perspectives on problems.

**Tolerate failure:** In spite of the best efforts and intentions, failure is not uncommon. Tolerance for failure needs to be imbibed. Failure has to be understood as a learning experience.

**Freedom to achieve:** For the mind to explore new ideas there has to be abundant freedom of thought and action. Organisation members must be properly guided towards achievement. A supportive climate will help gain control over the time and money invested in creative behavior.

**Offer recognition:** Creative individuals are motivated to work hard on tasks that interest them. They must be rewarded for the tasks well done. By offering recognition in such tangible forms as salary increase, recognition, the message gets conveyed that creative behavior is valued and rewarded.

## Factors Hamper Innovation

Rosabeth Kanter has developed a list of ten types of attitudes that stifle creative and innovative attempts or disposition of the people in the organization. Such attitudes will have a dampening effect on organizational creativity and innovation. An understanding of the following points may help you avoid getting into the trap.

- Viewing any new idea from below with suspicion- because it is new, and because it is from below.
- Insisting that people who need our approval to act first go through



- several other levels of management to get their signatures.
- Asking departments or individuals to challenge and criticize each other's proposals.
  - Expressing criticism freely and withholding praise where it is due. (Keeping the people on their toes). Creating a fear psychosis among people that they can be fired at any time.
  - Treating identification of problems as signs of failure in order to discourage people from letting you know when something in their area is not working.
  - Controlling everything carefully. Make sure people count anything that can be counted frequently.
  - Making decisions to reorganize or changing the policies in secret, and springing them on people unexpectedly.
  - Making sure that requests for information are fully justified, and making doubly sure that it is not given out to managers freely.
  - Assigning to lower-level managers, in the name of delegation and participation, responsibility for figuring out how to cutback, layoff, move people around, or otherwise implementing the threats you have thrown around.
  - And above all, never forget that you the higher - ups, already know everything important about this business.

## **Entrepreneurship**

It has now been fully recognized all over the world that entrepreneurship is the critical input for the economic development. Entrepreneurs are the people who identify new opportunities and exploit them. In the process, they contribute immensely for the growth of any nation by providing goods and services. Basically, entrepreneur sees a need and then brings together the manpower, materials, and capital required to meet that need. It involves the shifting of resources from '*low productivity*' areas to '*high productivity*' areas. Needless to say that in the absence of entrepreneurship, which acts as a catalyst agent, resources would remain simply unexploited and nothing worthwhile happens in any economic system.

## **Entrepreneurship vs. Managership**

Entrepreneurship involves initiating changes. Doing things in an innovative way. It refers to creation of a new organization. Management, on the other hand, refers to the ongoing coordination of the production process, which can be visualized as a continued combing of the factors of production. It involves managing an existing business. Consequent to the liberalization policies pursued by the government, Indian industry is exposed to stiff, sometimes, even cut-throat competition, not only from other enterprises within the country but also from outside. As a result, the axiomatic truth '*survival of the fittest*' has become the reality in the Indian corporate sector too. Failure of managements to respond appropriately to changing realities would cost them dearly. In the wake of profound changes in the various segments

of the environment – technologists, economic, socio-cultural and political – Indian industry has to unlearn its older practices and prepare itself to meet the challenges. To quote Peter Drucker, “*in turbulent times, an enterprise has to be managed both to withstand sudden blows and to avail itself of sudden unexpected opportunities*”. As such the need for entrepreneurial managers with innovative outlook who always search for change, respond to it, and exploit it as an opportunity is now greater than ever before. They are the ones who make a difference, while ordinary managers are effective only in managing stable, routine and cost-effective business.

### **Characteristics of Entrepreneurial Managers**

Let us, in this context, understand the psychological attributes that characterize entrepreneurial managers. In brief they are:

- Have high activeness;
- Posses an idea or a distinct way of doing things;
- Show greater openness to experience;
- Have a more internal focus of evaluation;
- Have a tendency to toy with elements and concepts;
- Are willing to take risks; and therefore
- Need greater psychological and autonomy.

### **Fostering Entrepreneurial spirit**

Fostering entrepreneurial spirit in organizations is no easy task. For that, organizations must be managed differently so that they become fertile grounds for new product ideas. Creation of such a congenial climate depends on the ability of the top management to redefine the following organizational parameters.

#### **Structure**

If necessary, modifications have to be effected in the structure of the organization so as to minimize the rigidities and complexities. All the bureaucratic tendencies have to be avoided. Structures with too many levels reduce the organization’s ability for timely response. Hence the trend now is towards simple and flat structures.

Following are some of the structural modifications which gained wider acceptance in the recent times to foster entrepreneurship in the existing business.

- wider span of control with fewer levels. This facilitates faster decision making because new ideas and proposals need not be scrutinized or pass through too many levels;
- Creation of autonomous units to try new product ideas. This is often described as creating ‘companies within companies’;
- Job descriptions are made less detailed unlike in the traditional structures;

- Controls are loose rather than tight; for, too many controls stifle entrepreneurial spirit of the people.

## Strategy

In a dynamic environment, companies that lack foresight are easily prone to become former leaders for the simple reason that they fail to adopt to retain their leadership. Business history is fully replete with such leader-to-loser stories. It has also been amply proved in several studies that the leading cause for the company's failure is the top management's obsession with current operations giving credence to the philosophy that '*existing products drive out new products rather than the other way round*'. The direction of the strategy in which the organizational resources are deployed should centre on innovation. The choice of the right strategy dictates the fortunes of the company.

## Organizational Culture

Culture, in the organizational context, refers to a set of values, dominant beliefs and the guiding norms shared by the members of the organisation. A good value system with internal harmony widely diffused and shared throughout the organisation would help induce entrepreneurial spirit. On the other hand, a confused value system with internal disharmony, poor work ethics and weak morale mars the spirit.

The following measures help to foster conducive culture within the organisation to breed and nurture entrepreneurialism.

- Strong commitment and support of the top management for innovation;
- Adequate freedom for the organizational members by pushing down autonomy for down the line;
- Tolerance for failure to boost up the morale, for new product ideas, as Peter Drucker points out, is like "frog's eggs". Of the thousands hatched, only a few survive. No individual in the organisation volunteers to experiment with new ideas, if failure involves career risks;
- Adequate reward systems to motivate innovative people through various reinforcing devices. In the west, lavish banquets are frequently organized to honour the champions, in addition to promotions, incentives by way of stock options, bonus, etc,

To sum up, entrepreneurship within the existing business involves identifying new opportunities and steering the organisation towards the development of new products and services. The entrepreneurial activities in the existing business as such collectively called 'corporate entrepreneurship' or 'intrapreneurship'. Barriers to entrepreneurship include the lack of ideas, market knowledge, general business know-how, lack of appropriate strategy, etc.

## **Review Questions**

1. Explain the importance of creativity in the organizational context.
2. Discuss the process of creativity and the important steps to be taken to develop new products and services.
3. Analyse the various measures to promote innovative spirit in the organizations. Also describe the factors that stifle innovation.
4. How is entrepreneurship different from managership? Make a logical presentation of what you understand about entrepreneurship in the existing business.

\*\*\*

---

## Lesson – 29 : Benchmarking

---

### Objectives

*After reading this lesson, you should be able to:*

- ▶ Understand The Concept And Evolution Of Benchmarking As A Quality Improvement Tool ;
- ▶ To Know The Advantages And Limitations Of Benchmarking; And
- ▶ To Equip With The Skills Required For Installing Benchmarking Practices.

### Lesson Outline

- ▶ Evolution Of Benchmarking
- ▶ Advantages Of Benchmarking
- ▶ Limitations Of Benchmarking
- ▶ Pitfalls Of Benchmarking
- ▶ Approaches Of Benchmarking
- ▶ Types Of Benchmarking
- ▶ Phases Of Benchmarking
- ▶ Review Questions

Benchmarking is a systematic method by which organizations can measure themselves against the best industry practices. Benchmarking is the search for best practices that will lead to superior performance. Benchmarking helps a company learn its strengths and weaknesses and those of other industrial leaders and incorporate the best practices into its own operations. It promotes superior performance by providing an organized framework through which organizations can learn how the “*best-in-class*” do things, understand how these best practices differ from their own and implement changes to close the gap. It is a tool for continuous improvement.

Benchmarking is defined as “*measuring our performance against that of best-in-class companies, determining how the best-in-class achieve those performance levels and using the information as a basis for our own company’s targets, strategies and implementation.*” Or more simply, “*the search of industry best practices that lead to superior performance*”. The term “best practices” refers to the approaches that produce exceptional results, which are usually innovative in terms of the use of technology or human resources and are recognized by customers or industry experts.

**What is a benchmark?** : A benchmark is a point of reference against which things are measured. In business, these points of reference or standards can take many forms. They are measured by questions about the product or service (e.g. how many, how much time, how much money, how reliable or how well it is made of?). By studying other organizations and comparing the answers to these questions, we will be able to measure our performance against that of others.

As a result, you will be able to set new goals and adapt the best practices for your organization. This, in turn, will help satisfy your customers with the best quality, cost, product and service.

### **Evolution of the concept of Benchmarking**

The concept of benchmarking is not new. In the early 1800s, Francis Lowell, a New England industrialist traveled to England to study manufacturing techniques at the best British factories. Henry Ford created the assembly line after taking tour of a Chicago slaughterhouse and watching carcasses hung on hooks mounted on a monorail move from one workstation to another. Toyota's just-in-time production system was influenced by the replenishment practices of U.S. supermarkets. Modern benchmarking was initiated by Xerox (in the 1980s), an eventual winner of the Malcolm Balridge National Quality Award for quality. IBM, Motorola and Xerox became the pioneers in instituting the benchmarking processes. Xerox initially studied their direct competitors and discovered that:

- their unit manufacturing cost equalled the Japanese selling price in the United States.
- the number of production suppliers was nine times that of the best companies.
- assembly line rejects were 10 times higher.
- product lead times were twice as long, and
- defects per hundred machines were seven times higher.

These results helped them to understand the amount of change that would be required to set targets to all the functional areas of the business.

### **Advantages of Benchmarking**

- Benchmarking promotes a thorough understanding of the company's own process i.e., the company's current profile (strengths and weaknesses) is well understood.
- Benchmarking process involves imitation and adaptation of the practices of superior competitors, rather than invention, thereby saving time and money for the company practicing benchmarking.
- Intensive studies of existing practices often lead to identification of non-value-added activities and plans for process improvement.
- Benchmarking enables comparison of performance measures in

different dimensions, each with best practices for that particular measure. It involves comparison with several companies who are best for the chosen measure. (Some common performance measures are return on assets, cycle time, percentage of on-time delivery, proportion of defects, percentage of damaged goods and time spent on administrative functions).

- Benchmarking focuses on performance measures and processes and not on products. Thus, it is not restricted to the industry to which the company belongs. It extends beyond these boundaries and identifies organizations in other industries that are superior with respect to chosen measures.
- Benchmarking allows organizations to set realistic, rigorous new performance targets and this process helps convince people of the credibility of these targets.
- Benchmarking allows organizations to define specific gaps in performance and to select the processes to improve. It enables the company to redesign its products and services to achieve outcomes that meet or exceed customer expectations.
- Benchmarking provides a basis for training human resources.

### **Limitations of Benchmarking**

- The primary limitation or weakness of benchmarking is the fact that best-in-class performance is not a static but a moving target.
- Benchmarking is not a panacea that can replace all other quality efforts or management processes that can improve the competitive advantage of a company.
- Benchmarking is not an “instant pudding”.

### **Pitfalls of benchmarking**

- The potential pitfalls of benchmarking could be overcome by:
- Involving the employees who will ultimately use the information and improve the process (participation can lead to enthusiasm).
- Relating process improvement to strategy and competitive positioning.
- Defining the firm's own process before gathering data for the purpose of comparison.
- Perceiving benchmarking as an ongoing process and not as a one-time project with a finite start and completion dates.
- Expanding the scope of the companies studied instead of confining to one's own areas, industry or to direct competitors, which is a narrow approach in identifying excellent performance that are appropriate to one's own processes.
- Perceiving benchmarking as a means to process improvement, rather than an end in itself.
- Setting goals for closing the gap between the existing performance (what is) and the benchmark (what can be).

- Empowering employees to achieve improvements that they identify and for which they solve problems and develop action plans.

### **Approaches of Benchmarking**

To compare one's business practices with those of other organizations, four common approaches to benchmarking are adopted. They are:

- Internal benchmarking ,
- Competitive benchmarking,
- Non-competitive benchmarking, and
- World-class benchmarking.

**Internal benchmarking** is done within one's organization or perhaps in conjunction with another division or branch office. Internal benchmarking is the easiest to conduct since data and information should be readily available and confidentiality concerns are minimized.

**Competitive benchmarking** involves analyzing the performance and practices of best-in-class companies. Their performance becomes a benchmark to which a firm can compare its own performance and their practices are used to improve that firm's practices. However benchmarking the competition could be difficult since it might be impossible to collect or learn a competitor's secrets. This type of information can often be obtained through a confidential survey of all competitors, usually conducted by a third party, quite often by a consulting firm.

**Non-competitive benchmarking** is learning something about a process a company wants to improve by benchmarking:

- a related process in the industry with another firm, the company does not directly compete with,
- a related process in a different industry, and
- an unrelated process in a different industry.

An advantage of this type of benchmarking is that new processes which could easily be adapted to one's organization might be discovered.

**World-class benchmarking:** This approach to benchmarking is the most ambitious. It involves looking towards the recognized leader for the process being benchmarked – an organization that does it better than any other.

### **Types of Benchmarking**

Three major types of benchmarking that have emerged in business are:

- i. Performance benchmarking or operational benchmarking,
- ii. Process benchmarking or functional benchmarking, and
- iii. Strategic benchmarking.



**Performance Benchmarking** involves pricing, technical quality, features and other quality or performance characteristics of products and services. Performance benchmarking is usually performed by direct comparisons or “reverse engineering” in which competitor’s products are taken apart and analyzed. This process is also known as “operational benchmarking: or “competitive benchmarking” and involves studying of products and processes of competitors in the same industry.

**Process Benchmarking** centres on work processes such as billing, order entry or employee training. This type of benchmarking identifies the most effective practices in companies that perform similar functions, no matter in what industry. For example, the warehousing and distribution practices of L.L.Bean were adapted by Xerox for its spare parts distribution system. Texas Instruments studied the kitting (order preparation) practices of six companies, including Mary Kay Cosmetics and designed a process that captured best practices of each of them and thereby cutting the cycle time by 50 percent. Companies should not aim benchmarking solely at direct competitors and it would be mistake if they do so. If a company simply benchmarks within its own industry, it may be competitive and have an edge in those areas in which it is the industry leader. However, if benchmarks are adopted from outside the industry, a company may learn ideas and processes as well as new applications that allow it to surpass the best within its own industry and to achieve distinct superiority.

**Strategic benchmarking** examines how companies compete and seeks the winning strategies that have led to competitive advantage and market success. One way to determine how well a company is prepared to compete in a segment and to help define a best-in-class competitor is to construct a Key Success Factor (KSF) matrix similar to the one shown in figure

Success Factor Matrix					
Competitive Analysis – Computer Industry... Segment					
Key Success Factors	Performance Rating				
	Weight	Our company	Competitor A	Competitor B	Competitor C
Sales force					
Distribution					
Suppliers					
R & D					
Service					
Cost structure					

**Figure 29.1: Success Factor Matrix**

**Areas to Benchmark:** Specific areas to benchmark at the operating level might include the following:

- Customer service levels
- Inventory management
- Inventory control (extent of automation)
- Purchasing
- Billing and collection
- Purchasing practices
- Quality process
- Warehousing and distribution, and
- Transportation.

**Guidelines to Benchmarking:** Companies approach benchmarking in different ways. IBM has a four step approach. AT & T has a nine step approach and Xerox a ten step approach. All these approaches have the general guidelines given below:

- ***Do not go on a fishing expedition:*** When preparing a benchmarking study, pickup a specific area in the organization that needs improvement. This may be quality, customer satisfaction, accounts payable or delivery time. Then do your homework, including thoroughly reviewing your own processes and procedures before picking a company that excels in the particular area chosen.
- ***Use Company people:*** The people who are going to implement changes need to see and understand for themselves, so it is they who should make the visits to other firms which are benchmarked and have the discussions with the concerned people. Further, the visits should be short and the working teams small.
- ***Exchange information:*** You should be ready to exchange information and provide answers in turn to any questions you might ask another company.
- ***Legal concerns:*** Avoid legal problems which might arise as a result of discussions that might imply price fixing, market allocation or other illegal activities. This could lead to problems. Do not expect to learn much about new products of competitors by the benchmarking process. Most benchmarking missions focus on existing products, business practices, human resources and customer satisfaction.
- ***Confidentiality:*** Respect the confidentiality of data obtained. Companies that agree to share information may strongly object if that information leaks out to a competitor.
-

## Phases of Benchmarking

There are four phases of Benchmarking:

- **Planning:** Identify the product, service or process to be benchmarked and the firm(s) to be used for comparison determines the measure of performance for analysis and collects the relevant data.
- **Analysis:** Determine the gap between the firm's current performance and that of the firm(s) benchmarked and identify the causes of significant gaps.
- **Integration:** Establish goals and obtain the support of managers who must provide the resources for accomplishing the goals.
- **Action:** Develop cross-functional teams of those most affected by the changes, develop action plans and team assignments, implement the plans, monitor progress and recalibrate benchmark as improvements are made.

**Benchmarking Process:** Specific steps in benchmarking vary from company to company but the fundamental or basic approach is the same. One company's benchmarking may not work at another organization because of differences in their operating concerns. Successful benchmarking reflects the culture of the organization, works within the existing infrastructure and is harmonious with the leadership philosophy.

## The Seven Step Benchmarking Model

Benchmarking is an ongoing process that requires data gathering, goal setting and analysis. These are accomplished by a seven step model. The seven steps are:

- Step 1: Identify what to benchmark
- Step 2: Determine what to measure
- Step 3: Identify who to benchmark
- Step 4: Collect the data
- Step 5: Analyze data and determine the gap
- Step 6: Set goals and develop action plan and
- Step 7: Monitor the process.

## Factors to be kept in mind to ensure success with benchmarking:

- Benchmarking must have the full support of senior management. Management should also be actively involved.
- Training is critical for the benchmarking team and process.
- Benchmarking should be a team activity. The team should include management, experts, consultants and especially those people directly involved in the process.
- Benchmarking is an ongoing process. It must be part of an organization's strategy and development. If well monitored, it serves as an important segment of a total quality management system.
- Benchmarking efforts must be organized, planned and carefully

managed. It is a structured approach and requires planning and monitoring just like any other management tool. On the whole, benchmarking can be used as an effective weapon against organizational complacency. Used correctly, benchmarking can lead you to the competitive edge in today's market place.

### **Review Questions**

1. What is meant by benchmarking? Describe the process of benchmarking.
2. Trace the evolution of benchmarking. Give some examples of U.S. firms who could achieve dramatic results by implementing benchmarking process.
3. Explain the pitfalls of benchmarking. How would you overcome those pitfalls?
4. Examine the important approaches of benchmarking. Given the Indian context, which of the approaches would you think give better results?

\*\*\*

## Case Study

### If Something Can Do Wrong – It Will

Mr. Ravi, a brilliant young man obtained his MBA degree from an Indian University in 1991 with specialisation in the area of finance. His basic degree is B.E in Chemical Engineering. The engineering background coupled with the management education aroused in him new spirits to strike on his own and thus developed a penchant to start an enterprise. Careful and systematic analysis of the various opportunities enabled him finally to zero in on the production and marketing of polythene bags that are increasingly used fertiliser and Cement industries. The location of a fairly good number of units of these two industries in the South (for instance, of the about 95 cement units nearly 40 are concentrated in the four Southern States) influenced his decision of the product choice. The fact that technology involved is also not complicated and volatile further reinforced his belief about the market potential.

To reap certain locational advantages, he preferred to set up the unit in a fast growing district headquarters town connected with a good network of transport and communication facilities. But the cost of land as well as its availability became a problem. With the limited funds at his disposal, he could not afford to buy land and construct the unit which involves the commitment of substantial portion of his meagre funds. On enquiry he came to know of certain sick units in the industrial estate in the outskirts of the town, which have ceased to function for some time in the past. The machinery in a few such units having been already auctioned, the sheds were available for sale lease. This opportunity came in handy for Mr.Ravi. He took on lease one such shed and spent about one lakh to effect a few changes to suit his requirements.

He started contacting the suppliers for the plant and machinery. He is confident of obtaining financial assistance to meet the fixed as well as working capital requirements of the business. But at the same time, he is also confused of the multiplicity of organisations/ agencies that have come up to cater to the needs of small scale entrepreneurs. He doesn't have adequate knowledge of the assistance available and the incentives offered by all these agencies to promote entrepreneurship.

Further, even though he doesn't for see any problems in the technical aspects relating to production, he is rather apprehensive of marketing the product. The demand for his product, being a derived one, is influenced by two factors – one, the demand for fertilisers, cement and other bulk commodities and two, the extent of the success made in replacing the gunny bags which are still in wider use. To add to his bother, Government of India, of late, is understood to have been contemplating to insist the use of gunny bags to protect the jute industry which has been languishing and is likely to vanish. However, all these problems could not deter the spirit of Mr.Ravi who is fully

determined and bent on going ahead.

### **Questions**

1. Was Mr.Ravi's product concept right?
2. Whose did Mr.Ravi go wrong in the whole plan of establishment of the unit?
3. Assuming that govt. had made the use of gunny bags compulsory, what alternatives do you suggest to Mr.Ravi at this stage?

\*\*\*

## Further Reading

1. Drucker, Peter, F., 1981. Management: Tasks, Responsibilities and Practices, Allied Publishers, New Delhi.
2. Hodgets, Richard M., 1986, Management Theory: process and Practice, Academic Press, London.
3. Stoner, James. A.F. and Freeman.E.R., 1989. Management, Prentice Hall of India, New Delhi.
4. Katz R.L., 1974. Skills of an Effective Administrator, Harvard Business Review, 52(5) 90- 102.
5. Newman, William Hsummer, Charles E. and Warren, E, 1974. The Process of Management: Concepts, Behaviour and Practice, Prentice Hall of India; New Delhi.
6. Alvin Toffler, 1970. Future Shock, Random House, New York.
7. Daniel bell, 1973. The Coming of Post – Industrial Society, Basic books, New York.
8. John B. Miner, 1978. The Management Process, Macmillan, New York.
9. Richard T. Pascale and Anthony G. Athos, 1981. The Art of Japanese Management, Warner Books, New York.
10. George R.Terry and Stephen G. Franklin, Principles of Management, AITBS, Delhi, 1988.
11. Milton Friedman, 1963. Capitalism and Freedom, Chicago Unit Press, Chicago.
12. Keith Davis, “The Meaning and scope of Social Responsibility” in McGuire(ed), Contemporary management, Prentice – Hall, Eaglewood Cliffs, 1974.
13. Massie, Joseph L. 1971. Essentials of Management, Practice Hall, Eaglewood Cliffs, N.J.
14. Steiner, George A. 1969. Top Management Planning, Macmillan, New York.
15. Gleuck, William F. 1980. Business Policy and Strategic Management, Mc.Graw – Hill, New York.
16. Barnard, Chester I. 1938. The Function of the Executive, Harvard University Press, Cambridge.
17. Chandler, Alfred D. 1962. Strategy and Structure, MIT Press Cambridge.
18. Chandler, Alfred D. 1962. Strategy and Structure, MIT Press Cambridge. Ghreck, William F. 1972, Business Policy; Strategy Formulation and Management Action, Mc Graw – Hill, New York.5. I. Chester Barnard.
19. Cleland, David, I, and William. R. King, 1975. Systems Analysis and Project Management. Mc Graw – Hill, New York.
20. Kast. F.E., and J.E. Rsenzweig, 1973. Organisation and Management: A Systems Approach, Mc Graw – Hill, New York.
21. Miner, John B. 1978. The Management Process, Mcmillan, New York.
22. Naisbitt, John. 1982. Megatrends, Warner Books, New York.
23. Lorsch, Jay W and Lawrence, P.R. 1970. Studies in Organisation

- Design, Richard D. Irwin, Homewood.
24. Claude S. George, Jr. 1968. The History of Management Thought, Prentice – Hall, England Cliffs, N.J.
  25. John R.P. French and Bertram Raven, 1959. The Bases of Social Power in Dorwin Cartwright (ed), Studies in Social Power, Institute for Social Research, University of Michigan.
  26. Harey Sherman, 1966. It all Depends: A pragmatic Approach to Organisations, quoted in A.F. Stoner and Freeman, Management, 1989, Prentice – Hall India, New Delhi.
  27. Peter F. Drucker, 1985. Innovation and Entrepreneurship, The free press, New York.
  28. Fred Luthans, 1975. Organisational Behaviour. Mc Graw- Hill, New Delhi.
  29. Stephen Robbins, 1966. Organisational Behaviour, Prentice – Hall, India, New Delhi.
  30. Umasekaran, 1989. Organisational Behaviour, Tata Mc Graw – Hill, New Delhi.
  31. Tripathi & Reddy, 2008. Principles of Management, Tata McGraw – Hill, New Delhi.
  32. Laurie Mullins, 2007. Management and Organisational Behaviour, Pearson, New Delhi.
  33. Meenakshi Gupta, 2009. Principles of Management, PHI Learning, New Delhi.
  34. Ricky Griffin, 2008. Management: Principles & Applications, Cengage, New Delhi.

\*\*\*



